



CITY OF OAKDALE PUBLIC WORKS DEPARTMENT

455 South Fifth Avenue • Oakdale, CA 95361 • Ph: (209) 845-3600 • Fax: (209) 848-4344

CITY
ADMINISTRATION
& FINANCE
DEPARTMENT
280 N. Third Ave.
Oakdale, CA 95361
(209) 845-3571
(209) 847-6834 Fax

COMMUNITY
DEVELOPMENT
DEPARTMENT
455 S. Fifth Ave.
Oakdale, CA 95361
(209) 845-3625
(209) 845-8903 Fax

FIRE DEPARTMENT
Station No. 1:
325 East "G" St.
Station No. 2:
450 S. Willowood Dr.
Oakdale, CA 95361
(209) 845-3660
(209) 847-5907 Fax

PARKS & RECREATION
DEPARTMENT
325 East "G" St.
Oakdale, CA 95361
(209) 845-3591
(209) 845-3692

POLICE DEPARTMENT
245 N. Second Ave.
Oakdale, CA 95361
(209) 847-2231
(209) 847-3790 Fax

CITY OF OAKDALE
WEBSITE
www.ci.oakdale.ca.us
E-MAIL
info@ci.oakdale.ca.us

May 6, 2026

The City of Oakdale invites you to bid on the following project:

School Avenue -Water Main Replacement (Project # 26-004)

Location: The 100 block of School Avenue and Olive St.

Project Timeline:

It is anticipated that the project will be awarded to the lowest responsive, responsible bidder at the City Council meeting scheduled for June 15, 2026, with a Notice to Proceed issued no later than June 30, 2026.

Work to begin: Immediately after City Council acceptance of bids

Work to be completed: Within 30 days of Notice to Proceed

Detailed Specifications:

Project Scope of Work

- Install 480 linear feet of new 8-inch C900 DR-18 water main along School Avenue.
- Abandon existing water line and properly seal in place.
- Contractor shall connect eleven (11) existing service lines to their respective meters and realign services to achieve a straight and uniform installation in accordance with City standards. (Attached)
- Remove existing fire hydrant at 135 School Avenue and install new fire hydrant within the public easement at that location. A blow-off assembly shall also be installed at the end of School Avenue near the existing fence line.
- Contractor shall provide all labor, equipment, and materials necessary to complete the work, including excavation, trenching, shoring, and traffic control. All trenches backfill and compaction shall conform to City standards. Surface restoration shall include placement of twelve (12) inches of aggregate base and three (3) inches of asphalt concrete trench paving.

- All appurtenant work required to deliver a complete and fully operational water system shall be included. All work shall be performed in accordance with City of Oakdale standards, specifications, and applicable regulatory requirements, including passing bacteria testing.
- The Contractor shall possess a **valid Class A contractor's license** issued by the California Contractors State License Board at the time of bid submission.
- All work shall be performed in accordance with City standards, specifications, and applicable regulatory requirements.

Mandatory Job Walk: On May 13, 2026, at 9:00 a.m. at the corner of School Avenue and Olive Street. Attendance is mandatory to submit a bid; bids from non-attendees will not be accepted.

Bids exceeding \$25,000 will require a Payment Bond of 100% of the contract price.

COMPLIANCE MONITORING

This project is subject to compliance monitoring and enforcement by the Department of Industrial Relations, Office of the Labor Commissioner.

PUBLIC WORKS PROJECT AWARD NOTIFICATION

The PWC 100 form should be completed on-line by the Awarding Body (City of Oakdale). The completion and the submission of this form fulfill the required public works project notification to both the Division of Apprenticeship Standards (Labor Code sec 1773.3 (replacing former DAS 13 notification) and the Division of Labor Standards Enforcement Public Works Compliance Monitoring Unit {8 Cal. Code Reg. sec. 16451 (a)}

CONTRACTOR REGISTRATION

In compliance with SB 854, no contractor or subcontractor may be listed on a bid proposal for a public works project (submitted on or after March 1, 2015) unless registered with the Department of Industrial Relations pursuant to Labor Code section 1725.5 [with limited exceptions from this requirement for bid purposes only under Labor Code section 1771.1(a)]. In addition, no contractor or subcontractor may be awarded a contract for public work on a public works project (awarded on or after April 1, 2015) unless registered with the Department of Industrial Relations pursuant to Labor Code section 1725.5.

CERTIFIED PAYROLL

All contractors and subcontractors must furnish electronic certified payroll records directly to the Labor Commissioner (aka Division of Labor Standards Enforcement).

For all new projects awarded on or after April 1, 2015, the contractors and subcontractors must furnish electronic certified payroll records to the Labor Commissioner.

As of January 1, 2016, the requirement to furnish electronic certified payroll records to the Labor Commissioner will apply to all public works projects, whether new or ongoing.

These requirements apply to all public works that are subject to prevailing wage requirement of the Labor Code without regard to funding source.

INSURANCE

\$2,000,000 General Liability and Automobile Liability Insurance will be required. Workers Compensation Insurance with limits of at least one million (\$1,000,000) will also be required along with a Waiver of Subrogation endorsement in favor of City, its officers, agents, employees, and volunteers. Certificates of insurance to be provided when bid is awarded.

Bids shall be received by Manuel Lopez via email at mlopez@oakdaleca.gov or hand delivered to 455 South 5th Avenue, Oakdale, CA 95361, up to but no later than 2:00 PM on May 20, 2026. No bids will be accepted after this time.

Please contact Manuel Lopez for additional information or questions regarding this project at 209-845-3619.

Engineer's estimate is not available for this project.

INFORMAL BID – Water Main Replacement Project (School Ave)

Please provide the following pricing/ quote for this project:

1. \$ _____

Signature



Date

Company Name

License #

DIR #

Map Key

- Water Line - 
- Fire Hydrant - 
- Blow off Valve 

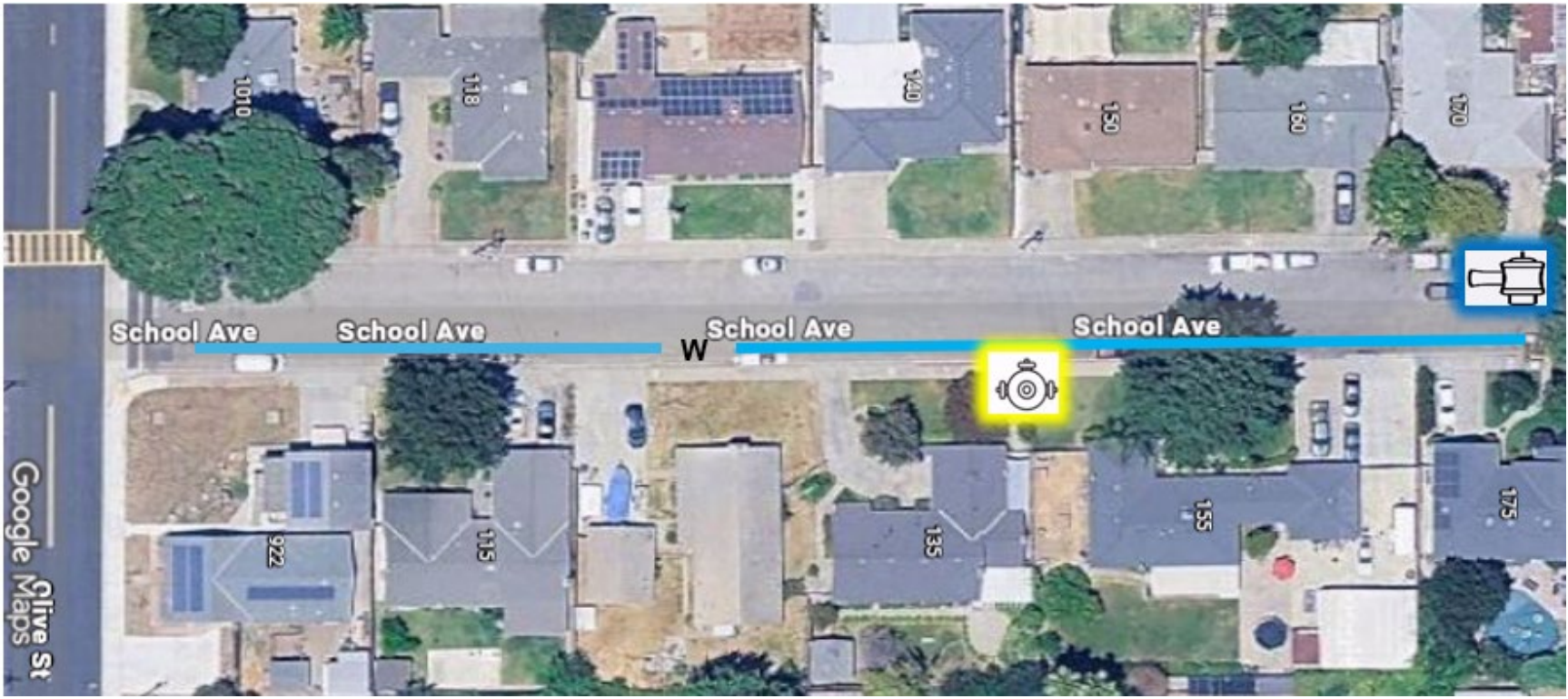

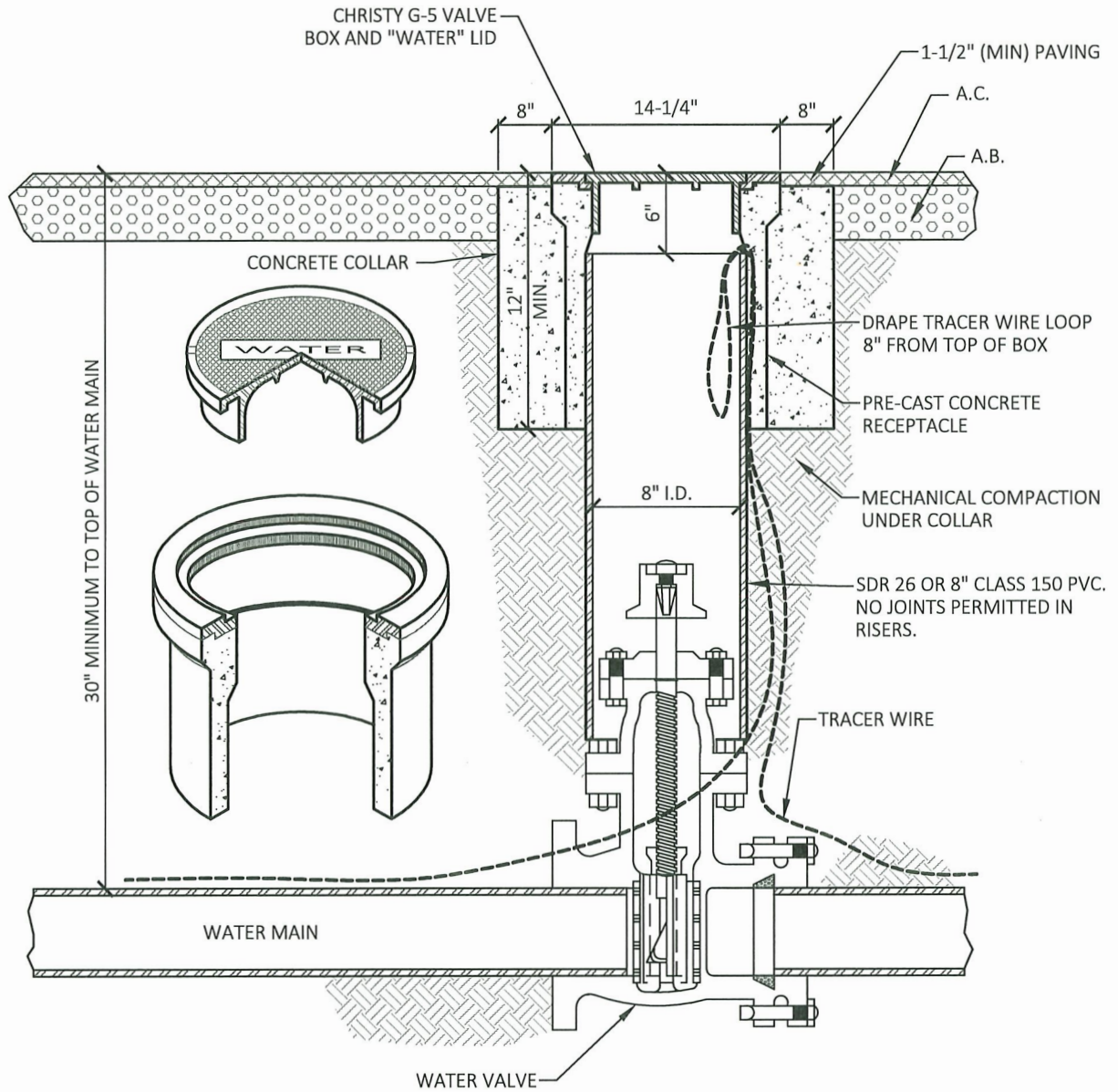

NOTES:

1. SEE SECTION 3 OF SPECIFICATIONS FOR APPROVED MATERIALS.
2. USE VALVE EXTENSION ON OPERATING NUTS DEEPER THAN 48". EXTENSION SHALL BE A PLACER WATERWORKS "RECYCLED WATER VALVE STEM EXTENSION" OR APPROVED EQUAL.

APPROVED BY CITY COUNCIL:
RESOLUTION: 2025-094

Rob Marler

ROB MARLER, P.E. - CITY ENGINEER

WATER VALVE BOX

CITY OF OAKDALE
DEPARTMENT OF PUBLIC SERVICES

DATE: 09-15-25

DRAWING NO.

3-A

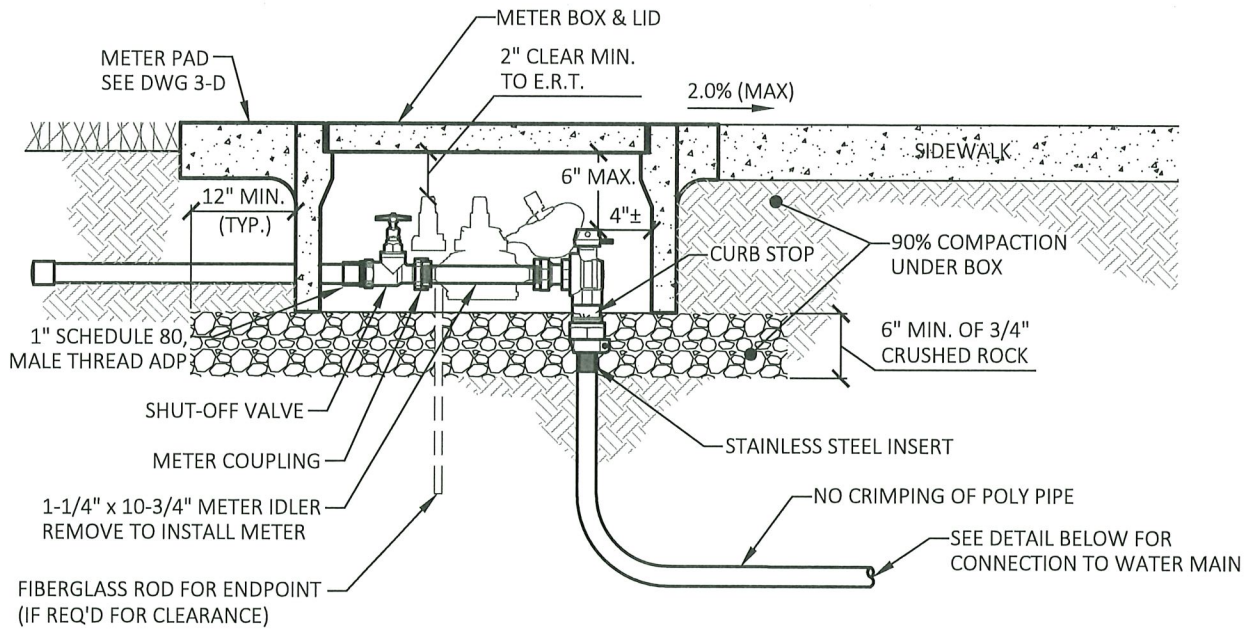

SECTION
(SHOW W/IDLER)

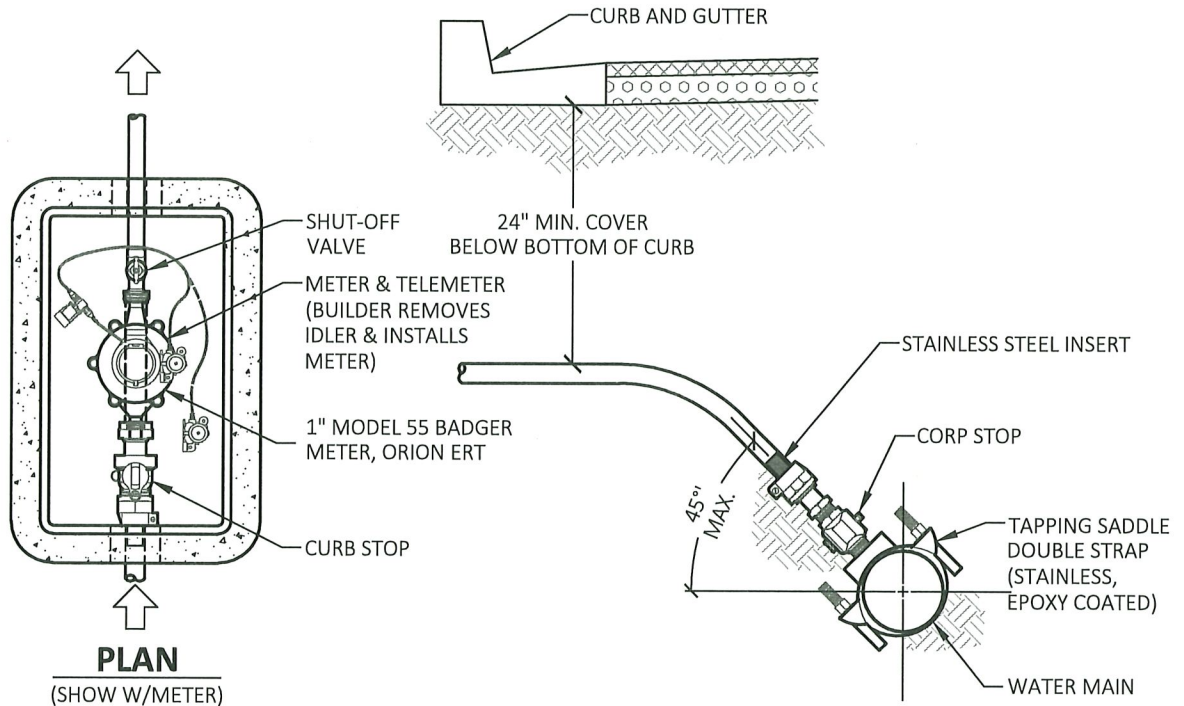

CONNECTION AT MAIN

NOTES:

1. SEE SECTION 3 OF SPECIFICATIONS FOR APPROVED MATERIALS.

APPROVED BY CITY COUNCIL:
RESOLUTION: 2025-094

Rob Marler

ROB MARLER, P.E. - CITY ENGINEER

**1" WATER SERVICE
(RESIDENTIAL)**

CITY OF OAKDALE
DEPARTMENT OF PUBLIC SERVICES

DATE: 09-15-25

DRAWING NO.

3-B

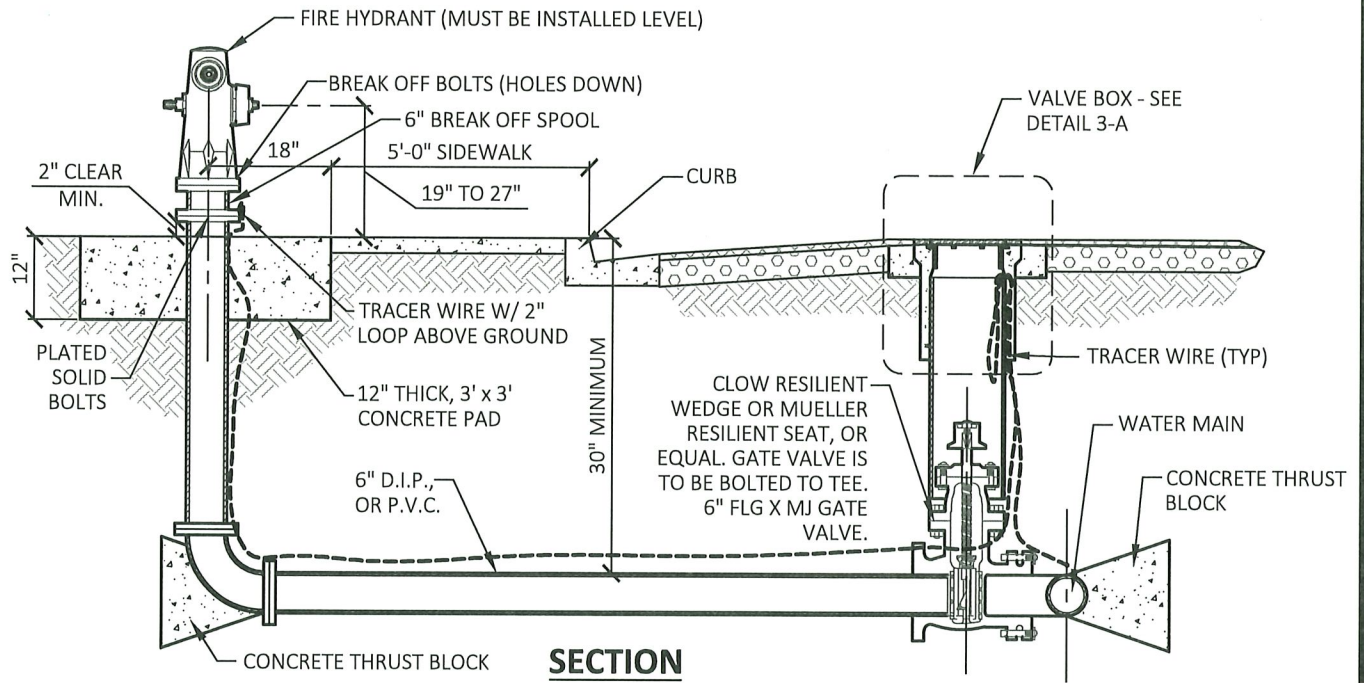

FIRE HYDRANT DISCHARGE LOCATION

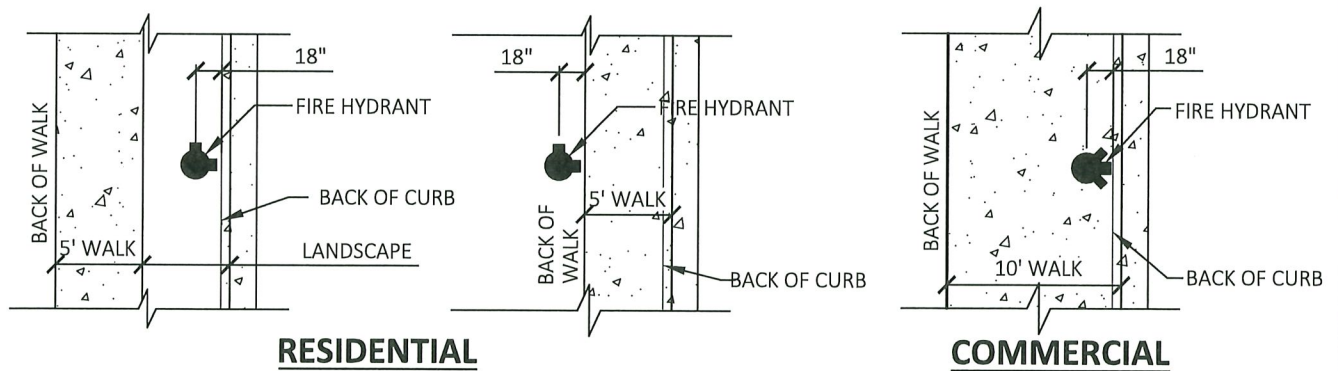

NOTES:

1. SEE SECTION 3 OF SPECIFICATIONS FOR APPROVED MATERIALS.
2. BREAK OFF BOLTS ARE TO BE HOLLOW BOLTS LOCATED THROUGH THE FIRE HYDRANT FLANGE WITH THE BOLTS POINTING DOWN.
3. ALL HYDRANTS SHALL BE POSITIONED SUCH THAT THE 4-1/2\"/>

APPROVED BY CITY COUNCIL:
RESOLUTION: 2025-094

Rob Marler

ROB MARLER, P.E. - CITY ENGINEER

FIRE HYDRANT

CITY OF OAKDALE
DEPARTMENT OF PUBLIC SERVICES

DATE: 09-15-25

DRAWING NO.

3-E

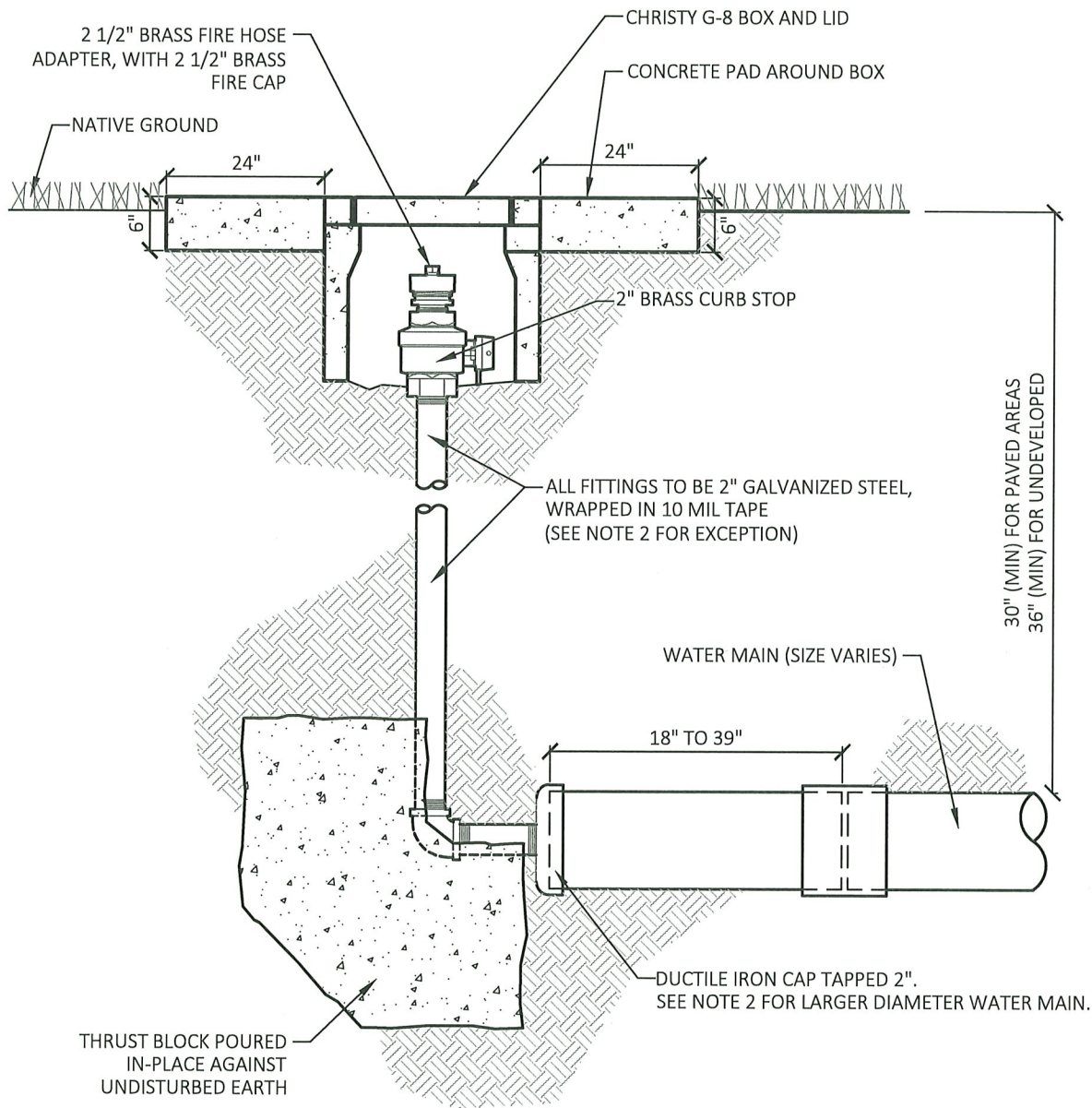

NOTES:

1. SEE SECTION 3 OF SPECIFICATIONS FOR APPROVED MATERIALS.
2. WATER MAINS THAT ARE 10" OR LARGER SHALL USE AN ECCENTRIC IRON CAP WITH 4" BLOWOFF.

APPROVED BY CITY COUNCIL:
RESOLUTION: 2025-094

Rob Marler

ROB MARLER, P.E. - CITY ENGINEER

WATER BLOW-OFF

CITY OF OAKDALE
DEPARTMENT OF PUBLIC SERVICES

DATE: 09-15-25

DRAWING NO.

3-G