

# Oakdale

---

# Improvement Standards



**CITY OF**  
**OAKDALE**  
**PUBLIC SERVICES**

Engineering Division  
455 S. Fifth Street  
Oakdale, California  
(209) 845-3625



**Adopted September 2025**

CITY OF OAKDALE  
**IMPROVEMENT STANDARDS**

PUBLIC SERVICES DEPARTMENT

455 S. Fifth Street

Oakdale, California 95361

Updated 09/15/2025

These Improvement Standards of the City of Oakdale were created by the Public Services Department to regulate the design and construction of public improvements and private improvements that serve the general public. These Improvement Standards consist of two parts 1) Specifications and 2) Drawings.

**TABLE OF CONTENTS**

**SPECIFICATIONS:**

---

1. GENERAL.....	1
2. STREETS.....	4
3. WATER.....	13
4. SEWER.....	26
5. STORM.....	31
6. SAFETY.....	35
7. UTILITIES.....	38
8. LIGHTING.....	40
9. LANDSCAPING (FUTURE).....	44
10. SITE IMPROVEMENTS.....	45
11. FIRE.....	47
12. STORM WATER QUALITY.....	59

**DRAWINGS:**

---

**1. GENERAL**

PROJECT BILLING INFORMATION FORM.....	1
SITE IMPROVEMENT REVIEW FORM.....	2
SUBDIVISION IMPROVEMENT REVIEW FORM.....	3
PARCEL MODIFICATION REVIEW FORM.....	5
STANDARD ENCROACHMENT PERMIT.....	6
GRADING PERMIT.....	8
FIRE HYDRANT USE PERMIT.....	10
GENERAL NOTES FOR CIVIL IMPROVEMENT PLANS.....	11
GENERAL NOTES FOR SUBDIVISIONS.....	1-A

**2. STREETS**

LOCAL RESIDENTIAL.....	2-A
FEATURE RESIDENTIAL.....	2-B
COLLECTOR RESIDENTIAL.....	2-C
2-LANE ARTERIAL.....	2-D
2-LANE ARTERIAL (With Class I Bike Path).....	2-E
2-LANE ARTERIAL (Commercial Frontage).....	2-F
4-LANE ARTERIAL (Commercial Frontage).....	2-G
4-LANE ARTERIAL (Adjacent to Residential).....	2-H

CUL-DE-SAC .....	.. 2-I
STREET KNUCKLE .....	.. 2-J
VERTICAL CURB & GUTTER .....	.. 2-K
DRIVE-OVER CURB & GUTTER.....	.. 2-L
SIDEWALK JOINTS.....	.. 2-M
PEDESTRIAN RAMP – CASE “A” .....	.. 2-N
PEDESTRIAN RAMP – CASE “B” .....	.. 2-O
PEDESTRIAN RAMP – CASE “C” .....	.. 2-P
DRIVEWAY – CASE “A” .....	.. 2-Q
DRIVEWAY – CASE “B” .....	.. 2-R
DRIVEWAY – CASE “C” .....	.. 2-S
ALLEY APPROACH .....	.. 2-T
VALLEY GUTTER .....	.. 2-U
MONUMENT AND RECEPTACLE.....	.. 2-V
ON-STREET PARKING .....	.. 2-W
CURB EXTENSION .....	.. 2-X
VERTICAL TO ROLL-OVER DRIVEWAY APPROACH.....	.. 2-Y

**3. WATER**

WATER VALVE BOX.....	.. 3-A
1” WATER SERVICE (Residential).....	.. 3-B
2” WATER SERVICE (Commercial).....	.. 3-C
METER BOX PAD .....	.. 3-D
FIRE HYDRANT .....	.. 3-E
THRUST BLOCK .....	.. 3-F
WATER BLOW-OFF.....	.. 3-G
COMMERCIAL BACKFLOW CONFIGURATION.....	.. 3-H
SMALL BACKFLOW (RP) - for 3/4” to 2” services .....	.. 3-I
LARGE BACKFLOW (RP) - for 3” to 10” services .....	.. 3-J
TEMPORARY BACKFLOW (RP).....	.. 3-K
DOUBLE DETECTOR CHECK (for fire lines) .....	.. 3-L
SAMPLING STATION.....	.. 3-M
AIR RELIEF VALVE.....	.. 3-N
METER BOX PAD & SAMPLING STATION.....	.. 3-O

**4. SEWER**

SEWER LATERAL .....	.. 4-A
CUT-IN WYE .....	.. 4-B
SEWER MANHOLE .....	.. 4-C
DROP MANHOLE.....	.. 4-D
TERMINAL CLEANOUT .....	.. 4-E
CONCRETE ENCASEMENT .....	.. 4-F
SAND & GREASE INTERCEPTOR.....	.. 4-G

**5. STORM**

CATCH BASIN .....	.. 5-A
CONCRETE PIPE INLET.....	.. 5-B
STORM DRAIN MANHOLE.....	.. 5-C
LARGE TRUNK MANHOLE .....	.. 5-D
SIDEWALK DRAIN.....	.. 5-E
RAINFALL INTENSITY CURVE .....	.. 5-F

<b>6. SAFETY</b>	
STREET NAME SIGN .....	6-A
STOP SIGN .....	6-B
BLUE REFLECTOR PLACEMENT .....	6-C
BARRICADE – DEAD END STREET .....	6-D
BARRICADE – STREET TRANSITION .....	6-E
<b>7. UTILITIES</b>	
TRENCH BACKFILL – T-CUT .....	7-A
MICROTRENCHING DETAIL .....	7-B
<b>8. LIGHTING</b>	
POLE FOUNDATION .....	8-A
INSTALLATION LAYOUT.....	8-B
PULL BOX.....	8-C
DRY UTILITY TRENCH SECTION.....	8-D
DECORATIVE LIGHT.....	8-E
LIGHTED BOLLARD.....	8-F
TREE WELL ELECTRICAL OUTLETS.....	8-G
<b>9. LANDSCAPING (FUTURE)</b>	
<b>10. SITE IMPROVEMENTS</b>	
ON-SITE DRYWELL – VERTICAL CURB & GUTTER .....	10-A
ON-SITE DRYWELL .....	10-B
PARKING LOT STANDARDS TYPICAL LAYOUT .....	10-C
(SINGLE) CONCRETE BLOCK TRASH ENCLOSURE.....	10-D
(DOUBLE) CONCRETE BLOCK TRASH ENCLOSURE.....	10-E
ROOF COVER TRASH ENCLOSURE.....	10-F
PIPE BOLLARD.....	10-G
<b>11. FIRE</b>	
SINGLE LANE TRAFFIC (721 Detectors, 752 Phase Selectors).....	11-A
MULTIPLE LANE TRAFFIC (721 Detectors, 752 Phase Selectors) .....	11-A-1
OPTICON PRIORITY CONTROL SYSTEMS .....	11-A-2
REQUIREMENTS ON PRE-FIRE PLANS.....	11-B
REQUIREMENTS ON PRE-FIRE PLANS .....	11-B-1
REQUIREMENTS ON PRE-FIRE PLANS .....	11-B-2
FIRE APPARATUS ACCESS ROADS.....	11-C
STREET NAMING STANDARD .....	11-D
STREET NAMING STANDARD.....	11-D-1
ILLUMINATED DIRECTORY .....	11-E
FIRE LANES OAKDALE FIRE DEPARTMENT.....	11-F
FIRE LANES OAKDALE FIRE DEPARTMENT .....	11-F-1
FIRE LANES OAKDALE FIRE DEPARTMENT .....	11-F-2
PLACARD AND LABELING REQUIREMENTS.....	11-G
PLACARD AND LABELING REQUIREMENTS.....	11-G-1
PLACARD AND LABELING REQUIREMENTS.....	11-G-2
MAXIMUM OCCUPANT LOAD SIGNS.....	11-H
FIRE HYDRANT – GATE VALVE INSTALLATION .....	11-I
RISER DETAIL .....	11-J
MAIN ELECTRICAL SERVICE DISCONNECT .....	11-K

## 1. GENERAL

---

### 1.1 GENERAL:

These Improvement Standards of the City of Oakdale include the Specifications and Drawings as contained herein. These Improvement Standards have been prepared to aid all persons engaged in the design and construction of public works within the City of Oakdale. Portions of these standards also apply to private work within the city limits, such as site improvements for commercial developments.

This document is not intended to be used as Contract Documents between the City or private developer and a contractor. Rather, separate Contract Documents must be prepared for each project with Special Provisions applicable to that particular project.

### 1.2 DEFINITIONS

The following definitions shall apply to these Improvement Standards:

City - City of Oakdale

CA-MUTCD – The current version of the California Manual on Uniform Traffic Control Devices.

Developer - Subdivider, Developer, Property Owner, Registered Engineer or Contractor proposing to design or construct public improvements (or private improvements that serve the general public) in the City of Oakdale.

City Engineer - City Engineer of the City of Oakdale or his authorized representative.

Improvement Plans – Plans of proposed improvements prepared by the Developer or City and approved by City Engineer.

Engineering Division - Engineering Division of the City of Oakdale.

Special Provisions - Specifications accompanying contract documents.

City Contractor - Persons engaged in construction under contract with the City of Oakdale.

Standards - These Improvement Standards of the City of Oakdale. They include both the text (specifications) and drawings contained herein.

State Standards - The current edition of the Improvement Standards and Plans of the State of California, Department of Transportation.

State Traffic Manual – The current edition of the California Department of Transportation Traffic Manual.

Utility - water, sewer, storm drain , gas, electric, telephone, cable, irrigation, railroads, etc.

### 1.3 APPLICATIONS:

The Engineering Division is responsible for approving and inspecting all underground and surface improvements within the City related to development, and accepting public improvements. They are also responsible to check and approve all Final Subdivision Maps, Final Parcel Maps, Lot Line Adjustments, Lot Mergers, etc. Generally, such work will be reviewed and approved under one of the following four application categories:

- A. SUBDIVISIONS: Includes residential or industrial/commercial developments where a property is subdivided into smaller parcels and new streets, underground utilities, or other public improvements will be installed. Such projects must receive Planning Approval (Tentative Subdivision Map or Tentative Parcel Map), and have obtained a set of Conditions of Approval prior to filing an application with the Engineering Division under this category. The following Applications/Guidance Documents provide a checklist and instructions

for processing an application under this category. The applicant shall submit all applicable information, materials, and fee deposit called for in these documents:

1. Subdivision Improvement Plan Review Form
  2. Project Billing Information Form
- B. SITE IMPROVEMENTS: Includes site improvements on private property. In most cases these improvements are part of a building permit application, and are subject to a planning approval process prior to seeking a building permit. The Building Department takes the lead on the building permit application, but the Civil & Landscape Plans must be processed separately through the Engineering Division for approval. The following Applications/Guidance Documents provide a checklist and instructions for processing an application under this category. The applicant shall submit all applicable information, materials, and fee deposit called for in these documents:
1. Site Improvement Plan Review Form
  2. Project Billing Information Form
- C. PARCEL MODIFICATIONS: Includes Parcel Maps (that don't require public improvements), Lot Line Adjustments and Lot Mergers. The following Applications/Guidance Documents provide a checklist and instructions for processing an application under this category. The applicant shall submit all applicable information, materials, and fee deposit called for in these documents:
1. Parcel Modification Plan Review Form
  2. Project Billing Information Form
- D. MINOR IMPROVEMENTS: Improvements that do not fall within categories A through C above, such as driveway installation or modification, or utility connections/modifications, etc., that occur within the public right-of-way, are considered "minor improvements" and are generally reviewed, approved, inspected and accepted under an Encroachment Permit (See 1.4.B).

#### **1.4 PERMITS:**

The following permits are administered by the Engineering Division.

- A. GRADING PERMIT: All grading and underground utility installation activities within the City are subject to a grading permit. This includes both Subdivisions (1.3.A), and Site Improvements (1.3.B). The permit application (which includes instructions and fees) is included in Section 1 of the Standard Drawings.
- B. ENCROACHMENT PERMIT: Any proposed improvements within City right-of-way, on City Property, or to be made to existing City infrastructure will require an encroachment permit. An encroachment permit may be issued as a stand-alone permit under Minor Improvements (1.3.D), or as part of a Subdivision (1.3.A), or Site Improvements (1.3.B). The permit application (which includes instructions and fees) is included in Section 1 of the Standard Drawings.
- C. FIRE HYDRANT USE PERMIT: Any use of fire hydrant water (for temporary construction water) is subject to a Fire Hydrant Use Permit. The permit application (which includes instructions and fees) is included in Section 1 of the Standard Drawings.

#### **1.5 PLANS:**

Improvement Plans prepared by the Developer shall be submitted to the Engineering Division for approval prior to commencement of any work. The Improvement Plans shall be printed on 24"x36" sheets and shall include Plan & Profiles for proposed improvements on all public streets. The General Notes sheet shall include the "City of Oakdale General Notes" found in Section 1 of the Standard Drawings.

Developer shall follow the application and permit procedures described in Sections 1.3 & 1.4, and pay applicable fees. All fees for plan check and inspection are deposit-based fees. Any unused portion of the deposit will be returned to the applicant upon project completion/acceptance. In the event the initial deposit is insufficient for charges incurred, the applicant will be notified by the city and an additional deposit will be requested.

#### **1.6 INSPECTION:**

All work and materials furnished under these Improvement Standards shall be subject to the inspection and approval of the City Engineer. The City Engineer shall have access to the work at all times and shall be furnished every reasonable opportunity for ascertaining that the methods, materials and workmanship are in accordance with the requirements and intents of these Improvement Standards. Failure of the City Engineer to note faulty material or workmanship during construction or on material submittals shall not relieve the Developer or Contractor of the responsibility for correcting such deficiencies at his expense.

All trench, bore, and slurry seal restoration work is subject to inspection and approval by the Public Works Department. The City reserves the right to require corrective action if restoration does not meet City standards or general industry standards. See Section 1.9 for additional information and standards.

#### **1.7 RECORD DRAWINGS:**

Prior to the City's acceptance of public improvements, the Developer shall submit a set of Record Drawings depicting any modifications made during construction.

#### **1.8 DEVIATIONS:**

These Improvement Standards are intended to be a minimum standard. However, any deviations intended by the Developer to exceed these Improvement Standards are to be specifically approved in writing by the City Engineer.

Materials proposed for use and not specified herein, shall be submitted for approval by the City Engineer prior to ordering such material.

Underground work shall not be backfilled or covered until an inspection by the City Engineer has been made and the work approved. Any work that is covered without an inspection shall be uncovered at the Developer's expense in order for an inspection to be made.

The City Engineer shall have access to the work at all times and shall be furnished every reasonable facility for ascertaining that the work done, materials used, and workmanship performed are in accordance with the requirements and intentions of these Improvement Standards. Failure of the City Engineer to not identify faulty material or workmanship during construction or on material submittals shall not relieve the Developer of the responsibility for correcting such deficiencies at his expense.

#### **1.9 SLURRY SEAL RESTORATION:**

Slurry seal restoration limits shall be determined by City staff and will typically be described in conditions of approval or an approved encroachment permit. When required, minimum standards for slurry seal restoration work shall include but not be limited to the conditions:

- Slurry seals shall be Type II, unless otherwise noted.
- The area to be sealed shall be properly cleaned, crack filled, and prepped, typical for application of a Type II slurry seal.
- Slurry seal limits shall extend from the edge of the pavement cut or repair to either (1) a minimum of five feet (5') in all directions, (2) to the nearest lane line, or (3) to the nearest edge of pavement, whichever option is greatest.
- If slurry limits fall within twenty-five feet (25') of another slurry limit, then the area between shall be included with a continuous, uniform application.

- Limits of slurry shall be clean and straight cut edges. Feathering shall be allowed at gutter pans or edge of pavement. Slurry seal that spills into the gutter pan shall be removed immediately.
- All striping and street markings shall be removed prior to application and replaced to match existing. All striping and street markings shall be thermoplastic. Striping application shall occur between 7 and
- Utility covers within the slurry limits shall be covered and protected during the application.
- Slurry seals shall be warrantied for a period of one (1) year from the date of acceptance. Reflective cracking shall be crack filled at the end of the warranty period.
- At the City's discretion, applicants may be required to post a refundable cash deposit for the guarantee of the slurry seal. Deposit amounts will be based on total area of slurry seal limits.

#### **1.10 GUARANTEE:**

The Developer, City Contractor or Utility shall inspect and repair all work done on improvements in the public right-of-way for a period of 1 year from the date the work is accepted as complete by the City Council or the City Engineer, whichever is the later date. If repairs are required during the 1-year period, the repaired areas shall be inspected and accepted, and the warranty extended for an addition year from the date of acceptance.

END OF SECTION

## 2. STREETS

---

### 2.1 GENERAL:

Street improvements in the public right-of-way shall be constructed by the Developer to conform to these Improvement Standards. Only a contractor with an appropriate license and required insurance may perform the work described herein.

Any existing street improvement damaged by the Developer shall be repaired by the Developer as required by the City Engineer. See section 2.27 for street moratorium information and requirements.

When an existing City Street Tree(s) is within a proposed improvement project, the Developer must meet the requirements of the City of Oakdale Tree Ordinance. Contact the Planning Department for further information before commencement of work.

Proper permits shall be acquired prior to commencement of work, per Section 1 of these standards.

### 2.2 GEOMETRIC DESIGN:

The street widths shall conform to applicable street section details in these standards.

The gutter slope shall not be less than 0.0025.

The streets shall be designed to collect storm water at intersections whenever possible.

Horizontal curves shall conform to the following criteria:

- (a) Minimum horizontal curve radii for centerline of residential streets shall be 250 feet. For streets other than residential, the curve radii for centerline shall conform to the current edition of the Caltrans Highway Design Manual, Standards for Curve Radii.
- (a) Street intersections shall be as near right angles as practical. In no case shall the angle of intersection be less than 70 degrees.

Curb Return Radii shall be 20' for Residential Streets, 30' for Arterial Streets, and 50' for Industrial Streets.

### 2.3 STRUCTURAL DESIGN:

The R-value design method used by the California Department of Transportation as detailed in the "Highway Design Manual" and the "Flexible Pavement Structural Section Design Guide for California Cities and Counties," shall be used as the basis to determine the structural section of the streets, except a safety factor shall be required only for a Traffic Index (T.I.) of 8.0 or greater.

The minimum T.I. used to determine the structural section shall be as follows:

<u>STREET</u>	<u>T.I.</u>	<u>INTERSECTION</u>	<u>T.I.</u>
Arterial	10	Arterial/Arterial	11
Industrial	9	Industrial/Industrial	10
Collector	8		
Local/Residential	6		
Cul-de-sac	4.5		

The limits of an intersection T.I. shall be the projection of the lip of gutter lines. T.I.'s are based on a 20-year design life.

The Developer shall be responsible for obtaining soil R-value tests, specifically supervised by a Licensed Registered Civil Engineer, in sufficient quantity to establish the quality of the soil and to provide a basis for the design of the structural section. R-value tests shall be taken at Developer's expense.

In order to establish the design, the following R-value tests will be required at the street sub-grade elevation and shall be at the Developer's expense:

- (a) A minimum of one R-value test shall be taken for all developments with an additional R-value test required for each 10 lots along a residential street, as directed by the City Engineer.
- (b) On major or collector streets where the frontage is less than 500 feet one R-value test shall be made. On major or collector streets where the frontage exceeds 500 feet, a minimum of one R-value test shall be taken at each 500 foot interval.

Exact locations of the R-value tests shall be as approved by the City Engineer. The Developer shall stake the field test locations and shall provide an existing ground and finish grade elevation for each test location. The Developer shall determine the depth of the R-value test. The Developer shall provide the results of the R-value tests to the City Engineer. The test results shall include a verification signed by a Licensed Registered Civil City Engineer that the R-value tests were taken at the depth and location(s) as shown on the approved Plan.

#### **2.4 CLEARING:**

Clearing and grubbing shall be done in accordance with Section 1 of these Specifications and Sections 16-1.01, 16-1.02 and 16-1.03 of the State Standards.

#### **2.5 EARTHWORK:**

Earthwork shall be done in accordance with Section 1 of these Specifications and Sections 19-1.01, 19-2.01 and 19-2.05 of the State Standards except that it shall further include the shaping of ground in the park strip and fill areas.

All embankment or fill materials shall be placed and compacted in accordance with Section 19-5.02, 19-5.03 and 19-5.04 of the State Standards, except that the City Contractor or Developer will only be required to strip the original ground of vegetation and compact the top 12 inches of original ground in place to not less than 95% relative compaction in accordance with Test Methods No., California 216 or 231, a nuclear density-moisture gauge, before the fill is placed.

The Developer shall obtain a disposal site for all of the roadway excavation not used on the jobsite. The Developer shall obtain and file with the City a letter showing permission and conditions for use of the disposal site. The Developer shall control dust at the disposal site and keep any streets free of excess material.

Developer shall comply with Section VIII of the San Joaquin Valley Air Pollution Control District (SJVAPC).

#### **2.6 SUBGRADE:**

All clods shall be broken and all rocks, hard ribs, and earth lumps over 2-1/2" inches in greatest dimension and other unsuitable material such as roots shall be removed from the jobsite. On industrial streets or where the T.I. is 10 or above, relative compaction of not less than 95% shall be obtained for a minimum depth of 2.5' feet below the finished grade. For all other streets, the sub-grade material shall be compacted to a firm, stable condition with approved equipment until a relative compaction of not less than 95% has been obtained to a minimum depth of 6 inches below the grading plane for the full width between the faces of the gutters. Location or depth of existing utilities may require alternate construction methods as approved by the City Engineer.

The finished subgrade shall not vary more than 0.05' foot above or below the planned grade at any point. Care shall be taken to obtain compaction around existing manholes and water valves.

Relative compaction shall be tested by the Developer, at Developer's expense, as directed by the City Engineer. In accordance with Test Methods No., California ASTM D-1557, and the test results shall be provided to the City Engineer.

## **2.7 AGGREGATE BASE:**

The aggregate base material shall conform to the requirements of Section 26-1.01, 26-102B, 26-1.03, 26-1.035, 26-1.04 and 26-1.05 of the State Standards for Class 2, 3/4" maximum combined grading.

An exception to Section 26-1.04 shall be that a single layer up to 0.7' foot shall be permitted.

Motor graders shall be permitted to spread and shape the aggregate base materials. The aggregate base shall be maintained in a well-mixed optimum moisture condition.

Relative compaction shall be tested by the Developer, at Developer's expense in accordance with Test Methods No., California ASTM D-1557 and test results shall be provided to the City Engineer.

## **2.8 ASPHALT CONCRETE:**

The asphalt concrete shall conform to the requirements of Sections 39-2, 39-3 and 39-6 of the State Standards. Asphalt concrete shall be Type B. Aggregate used in all but the final course shall be 1/2" inch maximum, medium grading. Asphalt concrete used in the final course shall be Type B. Aggregate used in the final course shall be as follows:

Major, Collector and Industrial Streets - 1/2" inch maximum, medium grading,

Residential Streets - 1/2" inch maximum, medium grading.

Aggregate for 1" inch overlays shall be as specified in the Special Provisions for each project.

The asphalt binder shall be grade PG 64-10 (Typical) or PG 7-10 (Special) as specified by the latest revision of the Section 92: ASPHALTS, State Standards.

- (a) The final surface course shall be paved in the number of passes approved by the City Engineer, starting from the curb and paving toward the centerline.
- (b) When paving the final surfacing course, there shall be a minimum of two rakers and one screed man per paving machine.
- (c) Rolling equipment shall conform to the requirements of Section 39-6.03 of the State Standards. Vibratory rollers will not be used.
- (d) The surface course shall be laid with a paving machine except when permitted otherwise by the City Engineer in difficult areas.
- (e) Paving machines shall have automatic joint control.
- (f) Extensions or wings shall not be permitted except as approved by the City Engineer.
- (g) Temperature requirements shall conform to the requirements of Section 39-6.01 of the State Standards.

(h) Deep strength or full depth asphalt concrete shall conform to the Special Provisions of the particular project.

## **2.9 ASPHALT PAINT BINDER:**

An asphalt paint binder shall be applied in conformance with Section 39-4.02 of the State Standards.

## **2.10 HEADER BOARDS:**

Header Boards shall be constructed to protect the edges of the asphalt concrete where streets are partially completed.

The boards shall be either Redwood or Douglas Fir with an American Wood Preservers Bureau Stamp indicating its use for ground contact and application of LP22 Waterborne preservative.

The boards shall be 2" inch x 4" inch dimensional of appropriate material.

## **2.11 CURBS AND SIDEWALKS:**

Curbs and sidewalks shall be constructed and repaired in accordance with the Drawings of this Section and the requirements of Chapter 30 of the Municipal Code. When matching 6" inch vertical curb sections, the return curb section is optional. The asphalt shall be cut a minimum of 24" inches from the lip of the curb.

Drive-over curb and gutter shall be monolithic, per Drawing 2-L.

Concrete delivery tickets with weighmasters' certificates or certificates of compliance may be required by the City Engineer.

The construction shall conform to Section 19-1.01 of the current State Standards, except when grade is machine cut or when curbs and sidewalks are placed on undisturbed native soil. However, the City Engineer may require 95% compaction wherever soil stability is questionable. The construction shall also conform to Sections 73-1.02, 73-1.03, 73-1.04, 73-1.05, 73-1.05-A, 73-1.05-B, 73-1.06 and 73-1.07 of the current State Standards, except for reference to payments, or as otherwise specified herein. Curbs shall be measured continuous through approaches. Approaches shall be measured to "back of curb line", when payment is made by the square foot.

Weakened plane joints shall be constructed at a maximum of 10' foot intervals as shown on Drawing 2-M. Depth of weakened plane joint shall be a minimum of 25% of the thickness of the concrete. Concrete shall be scored at equal intervals between weakened plane joints to approximate squares. Concrete surface shall be finished with a medium broom finish.

Special surface finishes or features such as exposed aggregate, color additives and redwood dividers require the written approval of the City Engineer.

Sidewalk shall have a cross slope toward the curb face of 1/8" inch per foot (1%) minimum to 1/4" inch per foot (2%) maximum.

Traffic, parking and street name signs on City Streets which require relocation because of the work will be relocated by the City, but two working days advance notice is required. Traffic Signs on State Highways and stop signs on streets entering State Highways must be relocated by Caltrans. Utility poles which require relocation because of the work shall be relocated by the utility company owning the poles. The Developer shall be responsible for protecting the work against damage and ensuring the safety of the public.

Transitions between different types of curb and different widths of sidewalk shall be constructed as shown in these standards.

## **2.12 DRIVEWAY APPROACHES:**

Approaches shall be constructed and repaired in accordance with Drawing No. 2-Q, 2-R, and 2-S, and Chapter 30 of the Municipal Code. The City Engineer may approve additional requirements where the Improvement Standards cannot be met.

The construction shall conform to Sections 73-1.02, 73-1.03, 73-1.04, 73-1.05, and 73-1.06, of the current State Standards, except for references to payments, or as otherwise specified herein. Curbs shall be measured continuous through approaches. Approaches shall be measured to the "back of curb line" when payment is made by the square foot.

Depth of weakened plane joint shall be a minimum of 25% of the thickness of the concrete. Concrete shall be surfaced with a light broom finish.

The total width of approaches serving a parcel of land shall conform to the following: For frontages having a vertical curb, the limit shall be 40% of the street frontage of the property or 36 feet, whichever is greater, in the case of corner lots, the limitation shall apply to each street frontage.

The minimum distance between approaches serving the same parcel of land shall be 20 feet. The distance between approaches on adjacent parcels may be less than 20 feet.

Approaches shall be located so they will not interfere with intersecting sidewalks, traffic signals, light poles, fire hydrants, or other public improvements unless specified approval is given by the City Engineer and the necessary adjustments to the improvements are accomplished without cost to the City of Oakdale.

## **2.13 ALLEYS:**

Alleys shall be constructed in accordance with these Improvement Standards and Drawing 2-T.

## **2.14 VALLEY GUTTERS:**

Valley gutters designed to permit drainage across a street shall be constructed as shown in Drawing 2-U.

## **2.15 ADA CURB RAMPS:**

ADA Curb Ramps shall be constructed at all intersections as shown in Drawing 2-N through 2-P.

The ramps must comply with current ADA (Americans with Disabilities Act), and State of California Title 24 requirements.

## **2.16 FINAL ADJUSTMENT TO UTILITY COVERS:**

The covers for all sanitary and storm manholes, lamp holes, water valves and survey monuments existing at the time paving takes place shall be adjusted (zero-tolerance) to final grade by the Developer within 10 working days after the pavement has been placed.

Where existing utility boxes are in the work area, their frames and covers shall be removed before subgrade compaction is made and a cover shall be placed to prevent dirt and loose material from entering the facility.

Base and surface material shall be placed over the covers, after which the frames and covers shall be set to finish grade.

### **2.17 TESTING:**

Material testing required by the City Engineer for work done under the provisions of this section shall be provided by the Developer and submitted to the City Engineer for approval.

Where approved by the City Engineer, materials certificates of compliance may be submitted in lieu of actual tests.

### **2.18 INSPECTION:**

The Developer shall request inspections as follow:

- (a) Completion of concrete subgrade preparation
- (b) Completion of forms installation
- (c) During placement of concrete
- (d) Completion of road subgrade
- (e) During placement of aggregate base
- (f) Completion of aggregate base grade
- (g) During placement of asphalt concrete
- (h) Prior to commencement of dry well drilling
- (i) Completion of final clean up

Other inspections to cover special items shall be as determined by the City Engineer as needed.

### **2.19 STREET MONUMENTS:**

Street Monuments and Monument boxes shall be placed as shown in Drawing 2-V, on the centerline of each street at the following locations:

- (a) Section corners
- (b) Quarter section corners
- (c) Major-Major intersections
- (d) Other points of survey significance, as directed by the City Engineer

The monuments shall consist of durable new material. They shall be 1" inch O.D. x 24" inch long galvanized iron pipe. The center of the top shall be the exact point monumented. The monument shall be tagged as required by the State of California Land Surveyor's Act.

### **2.20 BOUNDARY MONUMENTS:**

Boundary Monuments shall be placed on the exterior boundary of the subdivision at the following locations:

- (a) Changes of direction
- (b) Beginnings and ends of curves
- (c) Other points deemed necessary by the City Engineer

Boundary Monuments shall be placed in the same manner and of the same material as Street Monuments, except that in unpaved areas the top shall be at least 1' foot below the finished grade.

### **2.21 BLOCK CORNER MONUMENTS:**

Corner Monuments shall be placed at all Block Corners and Alley Corners.

Block Corner Monuments shall be placed in the same manner and of the same material as Street Monuments, except the top shall be set at least 1' foot below the ground surface.

### **2.22 LOT CORNER MONUMENTS:**

Lot Corner Monuments shall be placed in the same manner and of the same material as Street Monuments, except that they may be 3/4" inch O.D. and, in unpaved areas, the top shall be at least 1' foot below the finished grade.

Lot Corner Monuments shall be located where required by the City Engineer. The basic criteria for the location shall be as follows:

- (a) Lots shall have a monument at each corner except as otherwise provided by this section.
- (b) Lots that are created with zero back or side yards may have lot corners under building foundations, except those corners that are Block or Alley Corners.
- (c) Lots that are created as a part of a townhouse condominium development where realty is to be owned in fee by the individual lot owner shall be monumented using a minimum of 4 monuments for each contiguous group of lots. Contiguous groups of lots containing more than 10 lots shall have additional monuments as required by the City Engineer. Monuments shall not be located under footings or structures.
- (d) Condominium airspace developments where realty is not to be owned in fee by the individual lot owner shall have the exterior boundary monumented as required by Section 2.22 of these Improvement Standards.

### **2.23 CONCRETE:**

Portland cement concrete, unless otherwise specified in the Special Provisions, shall be Class B as defined in the current State Standards with a 28-day compressive strength of 2,500 pounds per square inch and a maximum slump of 3 inches. Concrete shall consist of Portland Cement, water and aggregate. Portland cement shall be Type II. Aggregates shall be washed before use and be free from any foreign matter. The aggregate shall be graded to provide a plastic, workable mixture of maximum density with a maximum size coarse aggregate of 1 inch x #4. The water shall be potable and no admixtures shall be used without approval of the City Engineer.

The cement, water and aggregates shall be combined at the batch plant and be thoroughly mixed. No water shall be added to the mixture after leaving the batch plant without approval of the City Engineer. All concrete shall be placed within 90 minutes after the introduction of water to the cement. The temperature of the concrete shall be not less than 50° degrees F and not more than 90° degrees F.

The concrete shall be consolidated by tamping or vibrating. Concrete which has rock pockets or honey combing after curing shall be removed and replaced.

All concrete shall be cured in accordance with Section 90 of the current State Standards.

### **2.24 DUST CONTROL:**

Dust control shall be the responsibility of the Developer. However, the City Engineer may perform emergency dust control and the cost shall be borne by the Developer.

On existing paved streets, the dust shall be controlled by the sweeping and removal of the dirt before it enters drywells or storm drains. On existing streets where paving has been removed, a temporary pavement or a dust palliative shall be used. Dust palliative shall be "Lignosulfonate" manufactured by I.T.T. Rayonier, Inc. Seattle, applied per manufacturer's specifications or SC70 Road Oil applied at approximately 0.15 gallons per square yard, or approved equal. Contractor shall comply with Regulation VIII of SJVAPCD.

In the work area, the dust may be controlled by use of water, but the drywells must be protected. Contract shall comply with current NPDES permit.

Water from City Fire Hydrants must be metered through a meter installed by the City Water Department. There is a charge for the water to the Developer. Water shall be furnished without charge to City Contractors.

## **2.25 SURFACE RESTORATION:**

The surface of the work area shall be restored to its original condition with material as described in each trench section drawing.

Work in easement areas must be confined to the easement and the surface must be reseeded, leveled, and all undesirable material removed.

Written agreements must be made with the property owners if work or equipment is to go outside the easement. The surface of the area outside the easement must be restored to the satisfaction of the property owner.

In the case of paved areas, excavations that leave 3' feet or less of existing surfacing shall have the remaining surfacing removed and repaved with the same material as the trench section.

Excavation in the shoulder area located within 3' feet beyond the edge of pavement shall be restored with a minimum of 8" inches of aggregate base material. The City Engineer may require a full structural section of the existing surfacing is at approximate ultimate grade.

The Developer is responsible for determining from the City Engineer the resurfacing requirements for each project when the plans are drawn or an encroachment permit is obtained.

Prior to any paving, all uneven or loose edges shall be trimmed in true and even lines parallel to the center line of the work.

The aggregate base shall conform to the requirements of Section 2.7 of these Improvement Standards.

A paint binder as specified in Section 2.9 of these Improvement Standards shall be applied to all existing vertical services and construction joints prior to placing asphalt concrete.

The asphalt concrete shall conform to the requirements of Section 2.8 of these Improvement Standards. The asphalt concrete shall be Type B-AR4000, medium grading of 1/2" inch or 3/4" inch maximum, whichever is required by the City Engineer.

## **2.26 CLEANUP:**

The Developer shall clean up the dirt and debris in all of the adjacent streets caused by the construction at least once each week or as requested by the City Engineer. All sidewalks, curbs, approaches, crosswalks, existing and new drain inlets, lawns, etc. shall be kept free of excess dirt and rubbish and kept in a clean and neat condition.

Before a final inspection of a project is requested, the following shall be completed:

- (a) All of the right-of-way, adjacent property, adjacent streets and alleys and all areas used by the Developer in connection with this project shall be cleared of all debris and excess material and left in a neat and presentable condition.

- (b) All paved areas shall be free of dirt and dust.
- (c) All concrete surfaces shall be left free of excess concrete, paving materials, liquid asphalt, dirt and dust.
- (d) All old and new drain inlet bottoms and outlet pipes shall be left free of all dirt and debris. Water shall be used to clean streets. Care shall be taken to keep sand and silt out of storm drains, catch basins, sanitary sewer manholes or drywells. Any storm drains, catch basins, sanitary sewer manholes or drywells affected by the work shall be cleaned by the Developer.
- (e) All sewer manhole bottoms shall be cleaned of all foreign matter and covers shall have all paving asphalt removed.

The Developer shall not remove temporary warning, regulatory, and guide signs prior to formal acceptance by the City Council. Such signs shall be removed when directed by the City Engineer.

**2.27 Street Moratorium:**

Streets that have been newly constructed and accepted by the City shall be subject to a five-year moratorium. No work shall be permitted within these streets unless expressly approved by the City Engineer. Approved work shall require, at a minimum, the following restoration measures: subgrade compaction and testing, 24" tee-cutting and transition paving of trenches or potholes, and a Type II slurry seal applied across the full width of the roadway between the two nearest intersections. Additional conditions may be imposed at the discretion of the City Engineer and will be specified in the approved encroachment permit.

END OF SECTION

### 3. WATER

---

#### 3.1 GENERAL:

Water mains and service shall be installed by a Developer holding the appropriate license for such work under the provisions of the State of California Business and Professions Code. The following Construction Standards for design and installation of Water Supply Pipe include pipe and appurtenance for residential and commercial developments. These Construction Standards are not applicable to the design and construction of major infrastructure improvements, including transmission mains, wells, pumping stations, tanks, and water treatment facilities. Pipelines with diameters greater than 12" shall be designed on a project-by-project basis as directed by the City Engineer. The design and construction of other major facilities shall be approved by the City Engineer.

#### 3.2 CURRENT STANDARDS

Pertinent and current requirements of the following standards shall be applicable and incorporated as part of the Construction Standards. In case of conflict, City of Oakdale design criteria shall govern. However, City of Oakdale Improvement Standards shall not be interpreted to reduce, lessen, or eliminate the following codes and requirements:

- (a) Environmental Protection Agency Drinking Water Regulations
- (b) Laws and Standards of the State of California, Department of Public Health, relating to Domestic Water Supply, and particularly therein the Standards of Minimum Requirements for Safe Practice in the Production and Delivery of Water for domestic use.
- (c) California Water Code
- (d) Title 17, Chapter V, Section 7583-7622, California Administrative Code, regarding cross-connections.
- (e) Modesto Fire Marshal and Uniform Fire Code (UFC)
- (f) AWWA, current standards.
- (g) City of Oakdale Drinking Water Permit as approved and amended by CDPH.

#### 3.3 DESIGN:

##### (a) WATER SUPPLY PRESSURE

Normal operating pressures of not less than 45 psi or more than 80 psi shall be maintained at service connections to the distribution system. A minimum pressure of 20 psi shall be maintained during fire demands.

##### (b) UNIT WATER DEMANDS

Average unit demands to be used for calculating water demands in residential developments shall be as follows:

Average Day Demand	0.5 gallons per minute (gpm)
Maximum Day Demand	1.0 gpm (2.0 x Average Day Demand)
Peak Hour Demand	2.0 gpm (4.0 x Average Day Demand)

For developments other than single family units, the developer shall submit estimated unit demands for each type of proposed use.

Total project demands shall be based on maximum day demands with fire flow, or peak hour demands, whichever is highest. Pipes shall be sized to provide for highest demand conditions while maintaining minimum pressures. Minimum pipe diameter shall be 8" in residential developments, and 10" in commercial developments.

Large projects may be required to replace/add water infrastructure in developed areas or outside of the project area to provide adequate flow, pressure, and reliability for the proposed development. No development shall have a single pipe supply; all developments shall be looped to ensure reliable delivery in the event of a single supply pipe failure.

(c) **REQUIRED FIRE FLOWS**

Required fire flows are to be established which meet the requirements of the Modesto Fire Marshall, State Fire Marshall, and the Uniform Fire Code (UFC).

The minimum required fire flow for single family residential water systems shall be 1,500 gallons per minute. Lesser fire flow requirements in conformance with UFC may be allowed with prior approval of the City Engineer and Fire Marshal. The minimum required fire flow for multi-family residential, and commercial/industrial developments shall be 2,000 gpm. The City of Oakdale shall provide a *maximum* of 3,000 gpm for any development. Required fire flow greater than 3,000 gpm must be provided by the project.

All water services shall be minimum 1 inch nominal diameter. Larger sizes shall be installed, as required, to provide adequate service to larger lots and/or higher water uses.

Where a water line crosses a sewer line, the water line shall be designed according to "Criteria for the Separation of Water Mains and Sanitary Sewers", Department of Health Services, State of California. See Section 1.8 "Deviations" for additional information.

**3.4 STANDARD LOCATIONS AND SPACING:**

Location of Water Main: All water mains shall be installed within public utility easements or rights of way. Installation of pipe in dedicated easements shall be allowed for temporary connections as approved by the City Engineer.

- (a) Water main location shall be 10 feet from centerline.
- (b) Designs shall place water mains above gravity and non-potable systems. Water supply pipes shall be maintained at the highest elevation possible, without excessive elevation changes. When necessary and unavoidable, water supply pipes shall drop below other utilities using 45-degree fittings to maintain valves at or near minimum cover and plumb. Install air release valves at high points in pipelines per Drawing 3-N.
- (c) Minimum cover under minor roadways (60 foot R/W or less) shall be thirty (30) inches. Minimum cover for pipe in unimproved areas shall be thirty six (36) inches. The maximum normal cover for water pipes shall be fifty-four (54) inches.
- (d) When it is necessary to install a water main within a privately owned parcel, an easement with minimum width of fifteen (15) feet and five (5) feet minimum clearance on either side.
- (e) If it is necessary to install a water main within a landscape corridor, no trees shall be planted within seven (7) feet of the water main center line.

- (f) Maintain ten (10) feet minimum horizontal distance between parallel water distribution and non-potable utilities (gravity or force sanitary sewer mains, storm drains, and non-potable water supply). In all instances the water main shall be one (1) foot above the sewer main. Less vertical separation may be approved by the City Engineer with use of special materials (i.e. ductile iron pipe, concrete encasement, etc.).
- (g) No water pipe shall be less than 5 feet in length unless cut or laid into fitting. Any pipe less than 10' in length shall be mechanically restrained.
- (h) The developer shall may be required to move, remove or abandon existing water mains or service lines in conflict with improvements and re-establish service to existing customers with minimal disruption to service.
- (i) Where a water main is installed in a major thoroughfare (84-foot right-of-way or greater), or in an area zoned for industrial use, dual mains (one pipeline on each side of the street) may be required to eliminate the need for extended services.

Main Valves: The distribution system shall be furnished with a sufficient number of valves so that isolating any single section of pipe will not result in removing from service: (a) a transmission main, (b) a length of pipe greater than five-hundred (500) feet in school, commercial, industrial, or multiple-family dwelling areas, (c) more than 15 residential service connections, or (d) more than two fire hydrants.

The valves shall be so located that any section of main can be shut down without going to more than two (2) locations to close valves. Valves shall typically be located at street intersections, within curb returns. Valves located between street intersections shall be located on property lines between lots. Install no fewer than two (2) valves per tee, and three (3) valves per cross. Install valves on main line at cul-de-sacs (not on branch).

Fire Hydrants: Fire hydrants assemblies shall be located as follows:

- (a) Fire hydrants shall be connected to distribution mains only. Fire hydrants shall not be connected to transmission mains.
- (b) Fire hydrants shall be located to minimize the hazard of damage by traffic. They shall have a maximum normal spacing of five-hundred (500) feet measured along the street frontage in residential developments and three-hundred (300) feet in commercial developments. Within residential areas, all other hydrants shall be located on property lines between lots at a minimum distance of three (3) feet from back of walk to allow maintenance personnel access to a hydrant that has been damaged without being sprayed with water. Hydrants located at intersections shall be installed at the curb return or within five (5) feet if a drop inlet is present.
- (c) A fire hydrant shall be installed on all permanent dead end runs including cul-de-sacs (two (2) inch blow-off assemblies shall be used on all temporary dead end runs per Drawing 3-G).
- (d) No more than three hydrants shall be placed on an eight (8) inch main between intersection lines. The minimum size main serving a fire hydrant shall be eight (8) inch diameter pipe. The pipeline connecting the hydrant to the main shall be a minimum of (6) inch diameter with an isolation valve installed at the main (on branch).

In addition, hydrants shall be placed on both sides of a major street and shall be spaced on each side according to the maximum distance allowed. On major streets where buildings and street are separated by a restrictive wall, hydrants shall be placed with a maximum distance of 500 feet between hydrants.

Fire hydrants shall also be spaced so that primary property improvements can be reached with a 250 feet maximum fire hose lay.

Services: Each individual residential building unit shall have a separate water service complete from the City water main to the property. Commercial, multi-family residential, and industrial services may be located on internal mains, as approved by the City Engineer. Water services are not permitted in easements without prior written approval of the City Engineer. This approval will be given only when it is physically impossible to serve the property directly from a water main in the right-of-way.

### **3.5 PIPE MATERIALS:**

Pipe shall be capable of withstanding all internal and external loads that may be reasonably expected to occur. In no case shall water supply pipe have an internal pressure rating of less than 150 psi. Higher pressure ratings may be required for special circumstances (i.e. less than 10' horizontal separation from non-potable utilities, special crossings, etc.).

Material options for pipe include the following:

- (a) Ductile Iron Pipe (D.I.P.) - Ductile Iron Pipe shall conform to the American National Standard A21-51-1976 (AWWA C151-1976).

Ductile Iron Pipe shall have "Tyton Joints" or "Ty-Seal Joints", and shall be cement lined in conformance with latest AWWA Specification C-104.

- (b) Polyvinyl Chloride Pipe (P.V.C.) - Polyvinyl Chloride Pressure Pipe shall be Class 150 DR 18, and shall conform to AWWA C-900. Polyvinyl Chloride Pipe shall be Pacific Western, Johns Mansville, CertainTeed or approved equal. All Polyvinyl Chloride Pipe shall be twenty (20) foot laying lengths and shall have Cast Iron outside diameters (C.I.O.D.'s). No pipe length shall be less than 5', unless laying into pipe fitting. Lengths less than 10' shall be mechanically restrained.

Joints of Polyvinyl Chloride Pipe shall have elastomeric-gasket bell ends or couplings. The bell ends shall be integral thickened bell end or integral sleeve-reinforced bell end. The bell end joints shall have a minimum wall thickness of the bell or sleeve-reinforced bell, equal to all points to the Standard Dimension Ratio (S.D.R.) requirements for the pipe. The minimum wall thickness in the ring groove and bell-entry sections shall be equal to or shall exceed the minimum wall thickness of the pipe barrel.

Bell and spigot pipe to be used on all new installations.

### **3.6 FITTINGS:**

Bends, tees, crosses, reducers, and other fittings shall be Cast Iron or Ductile Iron Pipe. All fittings shall be mechanical joint or flange.

Fittings shall be handled and jointed as specified for pipe installation herein before. Reaction or thrust blocking shall be constructed at bends, tees, dead ends and where changes in pipe diameter occur. Thrust blocking shall be made of Class B Concrete, and shall be placed between undisturbed ground and the fitting to be anchored. The area of bearing on the pipe and on the ground shall be that required by Drawing 3-F. The blocking shall be placed so that the joints of the pipe and fittings will be accessible for repair by placing 6 mil Visqueen around fitting, covering all nuts and bolts.

All fittings shall be flanged fittings with valves bolted on all bends, tees and fittings, in conjunction with the installation. All flanged fittings to use "drop-in" rubber gaskets (not full face).

All thrust blocks shall be inspected by city official before and after pour.

### **3.7 VALVES AND VALVE BOXES:**

Valves and valve boxes shall be installed at the locations shown on the plans.

All valves shall be Mueller resilient seat gate valve, American Flow Control compression resilient seat valve, M&H 3067 AWWA resilient seat gate valve, Kennedy resilient seat gate valve, Clow resilient wedge gate valve or approved equal, and shall be the rubber-seated, tight-closing type conforming to the current AWWA Specifications C-509. Valves shall open left and be equipped with a 2-inch AWWA operating nut. Dresser "450" butterfly valve conforming to the current AWWA Specifications C-504, or approved equal, may be installed.

Valve boxes shall be Christy G5 with Christy Cast Iron cover. The following materials may be used for extensions; 8-inch C900 Class 150 or SDR 26. All valve boxes shall be installed to finished grade as per Drawing 3-A. The riser is to rest on the bonnet of the valve.

### 3.8 WATER SERVICE MATERIALS:

The minimum size water service is 1 inch. Normally, single family residential properties can be adequately served by a 1-inch water service. For properties other than single family residential, and for non-typical single family residential, the City Engineer shall determine the water service size. For making such determination, the City Engineer shall take into account the anticipated water use, water pressure requirements, and property size.

Pipe material shall be as follows:

1" to 2" Diameter	Polyethylene (P.E.)
Larger than 2", smaller than 4"	Polyvinyl Chloride (PVC), Schedule 40 (except in City ROW)
4" and Larger	Polyvinyl Chloride (PVC), C-900

If abnormal or unusual conditions occur, the City Engineer may vary the pipe materials.

All water services, including meter boxes, shall be installed in accordance with Drawings 3-B or 3-C. Each water service shall have bronze corporation and curb stops. No. 10 copper tracer wire shall be installed over each service, connected to main and tested for conductivity upon completion. The following materials shall be used:

- 1) Plastic Pipe - All Plastic Pipe shall be ultra-high molecular weight polyethylene flexible pipe; Class 150 psi; PE 3406 for potable water; 1-inch Iron Pipe size (I.P.S.); outside diameter from 1.310 inches to 1.370 inches per latest AWWA Specification C901, and 2-inch copper tube pipe size (C.T.S.).

Manufacturer shall be: Yardley-02223; Driscopipe-5100 or Wesflex-PE 3406

- 2) Curb Stop, Meter Box, and related materials for 1 inch Water Service.

The curb stop shall be a 1-inch ball valve Ford BA13-444W-NL or Jones J-1971W (90 degrees).

The Corp Stop shall be a 1-inch Ford F1101-4-NL.

Meter adaptor: 1-inch meter coupling, Ford SP3.

Meter Idler: Schedule 80 PVC 10-3/4" inch x 1-1/4" inch threaded.

Shut-Off Valve: Ford SG13-444 or equal.

Meter Box: Christy Concrete Box N-30 with FL30D (fibrelite) lid.

- 3) Curb Stop, Meter Box and related materials for 2-inch water service.

The Curb Stop shall be a 2-inch angle ball valve, Ford BFA43-777W or BFA23-777W with a LA04-77.

The Corp Stop shall be a 2-inch Ford FB1100-78-NL.

Meter Box: Christy Concrete Box N-36 with FL36D (fibrelite) Lid.

- 4) Water Main Taps - All water mains shall be tapped with a standard hot tap machine, APAC, Mueller or Ford. Use of drills is acceptable on dry pipe only. If using hole saws or shell cutters, copper must be recovered. The following tapping saddles may be used: Romac or Ford, for sizes 4 inch and up shall be Romac - S.S.T. Only epoxy-covered double strap saddles will be used.

### **3.9 WATER SERVICE INSTALLATION:**

The services shall be installed as per Drawing 3-B or Drawing 3-C. Installation of the services shall consist of the following basic steps:

- (a) Excavation on the entire trench. Place the service line at right angles to the water main.
- (b) Thoroughly clean the water main.
- (c) Place and make tap as shown on the Standard Drawing(s).
- (d) Open tap valve immediately after making tap to flush material from the main line.
- (e) Insert stainless sleeves in the plastic pipe and tighten service line connections as per manufacturer's recommendation.
- (f) Use boring or pushing methods, but not washing methods, to place pipe under curb and sidewalk.
- (g) Install tracer wire.
- (h) Backfill and compact the dirt above the service line.
- (i) Service location to be marked by cutting or stamping a "W" on curb face.
- (j) Curb stop, stainless steel insert, meter idler, valve and P.V.C. stub unit and meter box to be placed at correct depth and distance from sidewalk.

Plastic service pipe shall not be heat-flared. Because of the variation in the outside diameter of the pipe, a saddle tap in lieu of the Quicktap may be required.

Special care shall be exercised to insure proper compaction is made under curb stop, so it is vertical and the meter idler is level. Compaction under meter box shall be 90% relative compaction under optimum moisture conditions, and shall be done when water service is adjusted to back of sidewalk.

### **3.10 FIRE HYDRANTS:**

Fire hydrants shall be Clow Model 850 for residential uses, and Clow Model 860 for commercial uses and shall conform to the latest AWWA Specifications, C-503, for wet-barrel fire hydrants. All hydrants shall be painted with "Safety Yellow" Polyurethane High Duty Industrial Enamel. See Drawing 3-E for details.

All tees, valves, and hydrant assemblies shall have restrained joints.

### **3.11 BACKFLOW PREVENTION ASSEMBLIES:**

All proposed water service connections to city water mains shall be subject to a cross connection survey by an approved City of Oakdale cross connection specialist to determine the type of backflow prevention assembly required. The following backflow assemblies are permitted:

1. Reduced Pressure Principle Backflow Assemblies (RP) are required for water service connections serving most commercial uses (subject to cross-connection survey), and all Fire Suppression systems that include chemical injection systems. RP devices shall conform to AWWA Standard C511, and shall be installed per Detail 3-H, and either Detail 3-I (for small service lines), or 3-J (for larger lines).

2. Double Check Valve Backflow Prevention Assemblies are required for all Fire Suppression systems that do not include chemical injection. Double Check assemblies shall conform to latest AWWA Standard C510, and shall be installed per Detail 3-L.
3. Temporary Backflow Prevention Assemblies are required during construction. Temporary Backflow devices shall be installed per Detail 3-K.

Materials: All backflow devices shall be lead-free bronze (non-composite material). Pipe from meter to device shall be galvanized steel or ridged copper (no lead or ductile iron). All galvanized pipe that is buried below grade shall be wrapped with 10 mil. tape.

All Backflow Prevention Assemblies shall conform to or include the following:

- (a) Conform to Title 17 and 22 of the California Administrative Code
- (b) Device shall be the same size as the water service line
- (c) Wye strainers shall be placed in line, upstream of device, horizontal
- (d) Device shall be placed on 4" thick class B concrete base with crane supports as needed
- (e) Trench backfill shall be compacted to 95% relative compaction
- (f) Device shall include a Thermal Protection Cover

Additionally, all small Backflow Prevention Assemblies, except those connected to Fire Suppression Systems, shall include a "Strong Box Smooth Touch" vandal resistant enclosure.

### **3.12 TEMPORARY AND PERMANENT BLOW-OFFS:**

Temporary and permanent blow-offs shall be installed at the locations shown on the plans in conformance with Drawings 3-G. Location of permanent blow-offs to be marked by stamping, cutting, or chiseling an "X" on curb face. The final length of pipe, prior to the blow-off, shall be 18 to 39 inches.

All salvaged temporary blow-offs shall become the property of the Developer and shall be removed from the job site before completion. When abandoning temporary blow-offs, line is to be capped at main, and a Corp stop is to be installed (male thread x male thread).

### **3.13 SAMPLE STATIONS:**

In accordance with the Coliform Rule as mandated by the State of California, sampling stations shall be installed by the Developer at the Developer's expense, where located by the City Engineer, approximately 1 sampling station for every 1/4 square mile.

Sampling stations shall be served by a 1-inch service installed in accordance with Drawing 3-M and 3-O, except that a meter idler assembly is not required. The testing nozzle shall be threadless and shall be between 36 - 48 inches in height. For instances where the station is installed per Drawing 3-O, the station will not be permitted to be installed where a transformer, hydrant, or electrolier is also planned in the same location.

The piping from the curb stop to the nozzle shall be brass or copper piping. All piping that is above grade shall be insulated with foam pipe insulation. All station housings shall be "Kupferle Foundry-Eclipse 88 (Winter Edition)".

### **3.14 CONNECTIONS TO EXISTING WATER MAINS:**

In order to protect public health and in accordance with State permit requirements, operation of the existing water system and its components shall be performed solely by a representative of City of Oakdale. Contractor shall never operate valves owned by City for any reason. When a new pipe or service is to be connected to a City owned water supply main, a work plan shall be submitted to the City for approval. The work plan shall define: (a) type of connection, (b) materials to be used, (c) water management, (d) sections of main to be isolated, (e) disinfection of materials, (f) flushing and testing upon completion, (g) schedule and duration of

work, etc. Once the work plan is approved, Contact City operations at least five (5) working days in advance of start of work to allow City representatives to contact existing customers of service interruptions.

Shutdowns shall be made only at times when there will be the least interference with consumer service. Connections shall be made only after complete and satisfactory preparations for such work has been made, in order that the duration of the shutdown is as short as possible. The Contractor shall have on site all piping, fittings, equipment and appurtenances as may be required to complete the connection.

Once work is started, it shall be under the supervision of the licensed City distribution operator. Contractor shall only proceed with the work if authorized by the City operator, and shall stop work if directed.

When work is done by the Developer, the Developer shall make all excavations and furnish, install and maintain such shoring, bracing and sheeting necessary for these connections as set forth in Section 3.12 of these Improvement Standards. The Developer shall connect to the existing system.

### **3.15 MATERIALS TO BE FURNISHED AND INSTALLED BY DEVELOPER:**

The Developer shall furnish all labor, material, equipment and appliances required to complete the water mains and services specified. Service taps on lines not yet accepted by the City shall be made by the Developer, after approval by the City Engineer.

### **3.16 STAKING OF WATER MAINS AND SERVICES:**

The water lines and services shall be staked by the Developer on projects installed by Developer, City Engineer on projects installed by the City.

### **3.17 EXCAVATION:**

The Developer shall perform all excavations necessary or required to construct all pipelines and structures. Excavation shall include the removal and disposal of all materials of whatever nature encountered. Trenches shall be excavated in open cut, following neat parallel lines equidistant from the centerline, which line shall be staked as set forth in Section 3.16 of these Improvement Standards. No tunneling or jacking will be permitted without written permission from the City Engineer. Trenches shall be of sufficient width to provide clearance beside the pipe for bracing and support and working space.

Care shall be taken to preserve all surface and subsurface facilities in the work area.

The trench shall be excavated to a minimum of 2 inches below the grade of the bottom of the pipe and 2 inches below the couplings of bells. If any of the trench bottom is in material too hard to permit proper bedding of the pipe, excavation must be carried to a depth at least 4 inches below the grade of the bottom of the pipe, and this over-excavation shall then be brought to grade with approved material compacted in place. Should the trench bottom at any location be of material which will not afford sufficient sound foundation, it shall be excavated as directed by the City Engineer and refilled to grade with approved materials compacted in place. Excess and / or rejected material shall be disposed of by the Developer.

### **3.18 SHORING, BRACING AND SHEETING:**

The Developer shall furnish, install and maintain such shoring, bracing and sheeting as required in Section 6.10 of these Improvement Standards. All trunks shall be over-excavated to a depth of 6" below pipe grade and filled with 6" clean fill sand for bedding.

After the pipeline has been installed and sufficiently backfilled to protect the pipe, all shoring, bracing and sheeting shall be removed. All voids left by the removal of such bracing shall be carefully filled with suitable material compacted in place. Shoring, bracing and sheeting shall conform to Cal-OSHA Standards.

### **3.19 DISPOSAL OF SEEPAGE, STORM WATER, OR SURFACE WATER:**

The Developer shall remove any seepage, storm water, or surface water that may be found or may accumulate in the excavation during the progress of the work. He shall furnish all pumps and other equipment necessary therefore and shall keep all the excavation entirely free from water at all times during the construction of the work. When pipe laying is in progress, the open ends of the pipe shall be closed by approved means to prevent entrance of water or dirt into the line. Whenever water is excluded from the pipe, adequate backfill shall be deposited on the pipe to prevent floating. Any pipe which has floated shall be removed from the trench and re-laid as directed by the City Engineer.

### **3.20 PREPARATION OF TRENCH AND LAYING OF PIPE:**

All pipe for water mains and laterals shall be laid to line and grade as shown on the approved plans and at such depths as to provide 30 inches minimum cover from top of the pipe to ultimate finish street grade. The Developer shall be responsible for verifying ultimate finish grade by requesting this information from the City Engineer.

When waterlines are being installed in a new subdivision, mainline pipe and the fire hydrant runs shall be installed prior to the installation of curb, gutter, and sidewalk.

The Developer shall field verify the depth and alignment of any existing water line prior to construction. If the existing water line is not exactly as shown on the improvement plans, the Developer shall obtain approval of the City Engineer before proceeding.

All water pipe runs shall have a No. 10 gauge solid, insulated with one-sixteenth (1/16) inch insulation, soft-drawn copper wire laid along and duct taped to the top of pipe to facilitate location of the pipe at a later date. The wire shall be stubbed up outside each valve box and be draped over the top into the box as shown on Standard Detail Drawing 3-A. All wire connections shall be stripped to bare wire connected with brass connectors shall be wrapped twice with 10mil PVC tape. Wire extending into the valve boxes shall have a one-sixteenth (1/16) inch polyvinyl chloride insulation. The contractor shall conduct a continuity test on all locating wire splices.

### **3.21 HANDLING OF PIPE AND ACCESSORIES:**

Proper implements, tools and facilities satisfactory to the City Engineer shall be provided and used by the Developer for the safe and efficient execution of the work. All pipe, fittings, valves, hydrants and accessories shall be lowered into the trench in such a manner as to prevent damage to pipe fittings. Under no circumstances shall pipe or accessories be dropped or dumped into the trench. All foreign matter or dirt shall be removed from the interior of pipe before lowering into position in the trench. Pipe shall be swabbed with Chlorine (50 ppm), and kept clean by means approved by the City Engineer during and after laying. All pipe and accessories shall be inspected for defects prior to lowering into trench. Any defective, damaged or unsound pipe or accessory shall be repaired or replaced at the Developer's or City Contractor's expense.

### **3.22 INSPECTION:**

All water lines shall be inspected for proper installation by the City Engineer, prior to backfilling of trenches. See Section 1.6 of these Improvement Standards. If work is to be completed after normal business hours, Contractor shall call (209) 845-3625 to arrange for an inspection to be made after normal business hours. Work shall not be covered without inspection, see Section 1.6 of these Improvement Standards.

### **3.23 TESTING:**

After establishing road subgrade and aggregate base has been placed, the entire length of each line shall be subjected to a hydrostatic pressure of not less than one hundred fifty pounds per square inch (150 psi) for a period of not less than 1 hour at line pressure. Fire lines shall be subjected to a hydrostatic pressure of not less

than two hundred pounds per square inch (200 psi) for a period of not less than 2 hours. No pipe installation will be accepted if leakage for the section tested exceeds a rate in gallons per hour per thousand feet (gph/1000') of 0.25 multiplied by the pipe diameter in inches (0.25 x diameter in inches).

The Developer shall perform the test prior to connecting to the existing system. The Developer shall furnish and install temporary caps, plugs for SP3 units, thrust blocks and other necessary materials needed to hold pressure on sections of line being tested.

Water for testing may be taken from the nearest blow-off, fire hydrant or other approved source. All pipe, fittings, valves, couplings, and other materials needed to fill the test lines with water shall be supplied and installed by the Developer. Care shall be taken not to contaminate the existing system.

The pump, gauge, pipe connection, and all necessary apparatus and equipment needed for the test shall be supplied by the Developer or City Contractor.

The Developer shall permanently stop all leaks. All pipe or joints which prove defective shall be replaced and the lines on which such defect or defects occur shall be tested again to determine final acceptability of the installation.

### **3.24 DISINFECTION:**

GENERAL: Disinfection of pipelines shall not proceed until all appurtenances and any necessary sample ports have been installed. Every effort shall be made to keep the water main and its appurtenances clean and dry during the installation process. Any piping, valves, fittings, and appurtenances which become contaminated during installation shall be cleaned, rinsed with potable water, and then sprayed or swabbed with a 50 ppm sodium hypochlorite disinfecting solution prior to installation. Water mains under construction that become flooded by storm water, runoff, or ground water shall be cleaned by draining and flushing with metered potable water until clear water is evident. Upon completion, the entire main shall be disinfected using a method approved by the City Engineer or licensed Water Distribution Operator. After adjustment of all devices to finish grade, system will be subjected to another round of follow-up bacterial testing. Disinfection and caution to be used when adjusting said devices.

#### METHODS:

##### A. Sodium Hypochlorite Solution (Liquid)

1. Sodium hypochlorite solution shall be used for cleaning and swabbing piping and appurtenances immediately prior to installation and for disinfecting all components of connections to the City's existing system.
2. Sodium hypochlorite (50 ppm) solution may be used for the initial disinfection of newly installed water mains. The solution shall be applied at a terminus of the system to be chlorinated using an injector which can adjust the amount of solution being injected into the piping system. The solution shall be injected at the appropriate concentration to achieve the specified concentration range of chlorine throughout the entire piping system. Where pumping equipment is used in conjunction with an injector, an integral backflow prevention device shall be installed and connected to the potable water supply.
3. Pumping equipment, piping, appurtenances and all other equipment in contact with potable water shall be disinfected prior to use. Water trucks shall not be used for disinfection of pipelines.
4. Sodium hypochlorite solution may also be used to increase the total chlorine residual if the concentration from the initial chlorination of the system is found to be low. The solution shall be added to the system in sufficient amounts at appropriate locations to ensure that the disinfecting solution is present at a concentration within the specified range throughout the piping system.

## PROCEDURE FOR DISINFECTING WATER MAINS AND APPURTENANCES:

- A. The pipeline shall be filled at a rate not to exceed 300 GPM or a velocity of 1 foot per second, whichever is less.
- B. Disinfection shall result in an initial total chlorine concentration of 50 ppm to 150 ppm. This concentration shall be evenly distributed throughout the system to be disinfected.
- C. All valves shall be operated with the disinfection solution present in the pipeline. All appurtenances such as air-vacuum relief valves, blowoffs, hydrants, backflow prevention devices, and water service laterals shall be flushed with the treated water for a sufficient length of time to ensure a chlorine concentration within the specified range in all components of each appurtenance. (Note the limitations for discharge of chlorinated water outlined below.)
- D. The Contractor will verify the presence of the disinfection solution throughout the system by sampling and testing for acceptable chlorine concentrations at the various appurtenances and/or at the test ports provided by the Contractor. Areas of the system found to be below the specified chlorine concentration level shall receive additional flushing as noted above and/or additional disinfection solution as necessary. (Note the limitations for discharge of chlorinated water outlined below). All testing will be done in the presence of the City representative.
- E. The chlorinated water shall be retained in the system for a minimum of 24 hours. The City will test the total chlorine residual. The system shall contain a total chlorine residual of not less than 80% of the initial total chlorine residual before the 24-hour soaking period began. If the total chlorine residual has decreased more than 20%, the system shall be soaked for an additional 24-hour period. If the total chlorine residual has not decreased after this additional 24-hour period, the system shall be flushed in accordance with the procedure detailed herein. If the total chlorine residual has decreased, the system shall be flushed in accordance with the procedure detailed herein and shall be re-disinfected.

### **3.25 FLUSHING:**

Following a successful retention period as determined by the District Engineer, the chlorinated water shall be flushed from the system at its extremities and at each appurtenance, using potable water from a source designated by the City. The minimum water velocity during flushing shall be 3 feet per second. Flushing shall continue until the replacement water in the new system is equal in chlorine residual to the potable source of supply, and as follows:

- A. All (Valves, Curb Stops, Blow-off, Hydrants or any other piping fixture) must be flushed until proper chlorine concentrations are achieved. No air can be in the system at any time after being flushed.
- B. Water free from air and at proper chlorine concentrations must remain in the system at least 24 hours before a bacteriological sample can be taken.
- C. If chlorine or air is found in the system at any point or time, the flushing process must be repeated.
- D. Once the flushing process is achieved and approved, the bacteriological testing can begin.

The Developer or Contractor is responsible for having a City approved California State certified drinking water laboratory collect water samples and perform bacteriological testing. Locations of tests shall be determined by the City Engineer.

### **3.26 DISCHARGE OF CHLORINATED WATER:**

- A. Indiscriminate onsite disposal or discharge to sewer systems, storm drains, drainage courses or surface waters of chlorinated water is prohibited. The environment to which the chlorinated water is to be discharged shall be examined by the Developer, licensed operator, and the City Engineer. Where necessary,

federal, state and local regulatory agencies shall be contacted to determine special provisions for the disposal of chlorinated water. Any discharge of chlorinated water to the environment shall require the neutralizing of the chlorine residual by means of a reducing agent in accordance with AWWA C651 and California Regional Water Quality Control Board.

- B. A chlorine reducing agent shall be introduced to the water prior to or at the point of discharge. A licensed distribution operator shall monitor the chlorine residual during the discharge operations. Total residual chlorine effluent limits for the discharge of chlorinated water from the testing of pipelines to surface waters shall have an instantaneous maximum value of 0.02 ppm.

The various methods of dechlorination available can remove residual chlorine to concentrations below standard analytical methods of detection, 0.02 ppm, which will assure compliance with the effluent limit. The Contractor will perform all necessary tests to ensure that the total residual chlorine effluent limitations listed above are met.

### **3.27 BACTERIOLOGICAL SAMPLING:**

- A. All fire hydrants, water services, backflow devices and other appurtenances shall be adjusted to finish grade before bacteriological sampling can begin, unless otherwise approved by chief water official.
- B. All sample sites must be free from excess chlorine or air. If one or all sample sites have excess chlorine or air in the system, the flushing process will start over.
- C. Samples are to be collected from all predetermined sites.
- D. All samples must be negative from bacteria.
- E. If one or all samples fail, then all samples must be retaken
- F. If all samples pass, a second set of samples must be taken, and pass before further action can be taken.
- G. If one or all samples from the second test fails, the disinfection process and flushing process must be repeated. If resampling, three (3) separate series of samples, 24, 48 and 168 hours apart, must pass.

Passing of Bacteriological Sampling:

- A. All samples must be reported as negative.
- B. Written results of testing have been received and accepted by the City of Oakdale and California Department of Health Services.
- C. After all the procedures have been logged and reported to the City of Oakdale, the City of Oakdale may consider the water main acceptable.
- D. On approval by the City Engineer or the City of Oakdale Water Department, the new water main system may be connected at this time.

### **3.28 CITY OF OAKDALE RIGHT OF RESPONSIBILITY:**

- A. The City Engineer or Engineering Division reserves the right to test the water after refilling the water main, and if not found to be safe, the bacteriological quality may require the Developer to re-chlorinate the water main, until the water quality is proven to be safe and satisfactory.
- B. The City Engineer or Engineering Division reserves the right to require the Developer to provide all necessary items to protect City of Oakdale Potable Water System.
- C. The City of Oakdale reserves the right to impose all costs associated with the Disinfection of City of Oakdale Water Main System to the Developer.

### **3.29 BACKFILLING AT EXISTING IRRIGATION LINES (O.I.D.):**

Whenever it is necessary to cross an existing irrigation pipe, the backfill shall be made by use of a pneumatic tamper. The entire area under the irrigation pipe, 2 feet on either side and 6 inches on top of the pipe shall be tamped to 95% compaction.

### **3.30 BACKFILLING OF TRENCH:**

Prior to the pressure test on the pipe, the trench shall be backfilled. On completion of the pressure test, taking particular care to properly bed the entire length of pipe, the remaining portion of the trench shall be backfilled and compacted as shown on Drawing 7-A. Tests for compaction shall be made in accordance with N-Cal-Test Method 216 or 231 and ASTM D-1557. Backfill material in undeveloped streets shall be free of objectionable matter, such as vegetation, large clods and asphaltic paving material.

In undeveloped streets, ponding or jetting may be permitted when specifically approved by the City Engineer, if this method does not hinder subsequent operations. Ponding or jetting will not be allowed in existing paved streets.

The Developer shall take proper precautions to prevent floating of the pipe when flooding is used for compacting the trench and the Developer shall be responsible for damage resulting there from.

### **3.31 RESTORING SURFACE:**

The surface of all trenches shall be filled and compacted so that the surfaces will conform to the condition of the surrounding ground. The paving requirements of the plans shall be met regardless of type of existing surface. Existing pavement shall be cut in neat parallel lines.

All surface restoration shall comply with Section 2.25.

### **3.32 UTILITY COVER ADJUSTMENTS:**

All utility covers shall be adjusted to the final grade with zero tolerance.

Water Meter Boxes shall be adjusted to final grade of paving per Section 2.16 (Final Adjustment of Utility Covers) of these specifications.

END OF SECTION

## 4. SEWER

---

### 4.1 GENERAL:

Sewers shall be installed by a Developer holding the appropriate license for such work under the provisions of the State of California Business and Professions Code.

### 4.2 DESIGN:

All sewers shall be sized to carry the quantity of sewage which will be discharges from their service area. Minimum sewer pipe slopes are as follows: 8" S=0.0035, 10" S=0.0025, 12" S=0.0020.

All lateral sewers shall have a minimum cover of 3 feet, 6 inches from the top of the pipe to finished grade at the flow line of the curb. Sewers with less than minimum cover shall be cast iron, ductile iron C-900, or shall be constructed with special beddings approved by the City Engineer.

Sewers within 100 feet of domestic wells shall be cast iron or ductile iron and shall meet the requirements of the California Department of Public Health.

Sewer mains shall be located on centerline, unless otherwise directed by the City Engineer. Where a sewer line crosses a water line, the sewer line shall be designed according to "Criteria for the Separation of Water Mains and Sanitary Sewers", Department of Health Services, State of California.

As a minimum, sewer mains shall be extended across property frontage.

### 4.3 MANHOLES:

Manholes shall be constructed as shown in Drawing 4-C at all changes in vertical or horizontal alignment, and at all pipe intersections. A drop manhole shall be installed per Drawing 4-D when the vertical distance between the invert of incoming sewer line is more than 36" above the invert of the main line. The maximum distance between manholes shall be 400 feet. A terminal manhole as shown in Drawing 4-E shall be constructed at all dead-end runs. Manhole bases may be cast-in-place, Class B concrete or pre-cast reinforced concrete and shall extend beyond the outer wall of the manhole. Starter barrels and cones are not allowed on cast-in-place bases. Precast bases shall conform to ASTM Specification C-478 and shall be placed on a minimum of 4 inches of crushed rock, of 3/4" inch maximum size. The rock shall be placed on undisturbed native soil.

Elevation differentials of inlets and outlets must conform to the improvement plans. The channel through the manhole shall be formed by laying the pipe through the manhole and removing the upper half of the pipe after the concrete has set. Special care shall be taken in the finishing of the interior of all manholes to obtain the best hydraulic characteristics. All rough edges shall be chipped away and plastered to leave smooth surface. Where called for on the plans, stubs shall be installed and plugged at the upstream end in a manner approved by the City Engineer. All pipes in and through manhole base shall have a water tight seal (donut).

Manholes shall be constructed for all laterals that are larger the 4 inches.

Manholes shall be constructed of precast reinforced concrete sections which conform to A.S.T.M. Specifications C478. The frame and cover shall conform to the elevation of the adjacent ground or pavement.

### 4.4 PIPE FOR NEW SEWER MAINS & LATERALS:

Sewer pipe shall be Poly Vinyl Chloride or Ductile Iron. Compression joints shall be used for all pipe and shall conform to the current Improvement Standards of the A.S.T.M. F477 for PVC and C111/421.11 for Ductile Iron.

Polyvinylchloride Pipe shall conform to the current Improvement Standards of A.S.T.M. D2241 SDR-26.

Cast Iron Pipe shall conform to the current Improvement Standards of the American National Standards Institute (ANSI) A21.6, and shall be Class 150, with bell and spigot joints. Cast Iron fittings shall conform to ANSI/AWWA C110-77. In areas of minimum cover, (typically 2 to 3 feet), No-Hub Cast Iron Pipe and fittings conforming to CISPI 301 and 310 may be used. However, all No-Hub Cast Iron Pipe and fittings, including services, shall be hydrostatically tested in accordance with Section 4.14 of these Improvement Standards. The hydrostatic test shall be performed after the pipe and fittings have passed the television inspection.

Ductile Iron Pipe shall be Class 50 and shall conform to the current Improvement Standards of the ANSI/AWWA C151/A21.51. All fittings shall conform to ANSI/AWWA C110/A21.10.

#### **4.5 STAKING OF SEWER MAINS AND SERVICES:**

The sewer mains and services shall be staked by the Developer on projects installed by Developer and by the City Engineer on projects installed by the City.

#### **4.6 EXCAVATION:**

Excavation shall include the removal of all materials encountered. All trenches shall be excavated in open cut following neat parallel lines equidistant from the pipe centerline as shown in Drawing 7-A.

Maximum width of the trench at the level of the top of pipe shall not exceed the outside diameter of the pipe barrel plus 24 inches.

At no time shall there be more than 300 feet of trench open per trenching machine, including the section ahead for pipe laying and the section behind which is not completely backfilled.

Excavation shall be made at least 4 inches below the grade of the bottom of the pipe in areas where the material is too hard to permit proper bedding. This over-excavation shall be brought to grade with approved material compacted in place.

Any areas which do not provide a firm foundation shall be over excavated as directed by the City Engineer and refilled to grade with approved materials compacted in place.

Excess and/or rejected material shall be disposed of by the Developer.

No tunneling or jacking will be permitted without written permission from the City Engineer.

#### **4.7 SHORING, BRACING AND SHEETING:**

The Contractor shall furnish, install and maintain such shoring, bracing and sheeting as required in these Improvement Standards under Section 6.10 Safety. All shoring, bracing and sheeting shall conform to Cal-OSHA Standards.

After the pipeline has been installed and sufficiently backfilled to protect the pipe, all shoring, bracing and sheeting shall be removed. All voids left by the removal of such bracing shall be carefully filled with suitable material compacted in place.

#### **4.8 SEEPAGE, STORM WATER, OR SEWAGE:**

The Developer shall remove from the trench any seepage, storm water, or sewage that may be found or accumulated during the progress of the work, and shall furnish all pumps and other equipment necessary therefore. The Developer shall also keep his completed work reasonably free from accumulation of water and sewage and shall free it entirely at such times as may be required by the City Engineer for the purpose of inspection. The removed material shall not be discharged into the sewer.

#### **4.9 LAYING PIPE:**

The pipe shall be laid to conform with the prescribed lines and grades. The line and grade shall be obtained by means of a laser beam or by measuring a tightly stretched string or wire set from the survey stakes. The Developer shall field verify the depth and alignment of any existing sewer main prior to construction. If the existing sewer main is not exactly as shown on the improvement plans, the Developer shall obtain the approval of the City Engineer before proceeding. All adjustments of pipe to line and grade shall be made by scraping away or filling in and tamping under the body of the pipe, not by blocking or wedging.

Manufacturers' recommendations on proper procedure for laying pipe shall be followed.

#### **4.10 SEWER SERVICE MATERIALS:**

General: Each individual property shall have a separate sewer service (s) complete from the sewer main to the property line. The minimum size sewer service lateral is a 4 inch. Sewer services are not permitted in easements without prior written approval of the City Engineer. This approval will be given only when insufficient grade makes it impossible to serve the property directly from a sewer main in the right-of-way.

Normally, single family residential properties can be adequately served by a 4-inch sewer service lateral. For properties other than single family residential, and, for other non-typical family residential, the City Engineer shall take into account the anticipated sewer use, and property size.

P.V.C. or Ductile Iron Pipe shall be used for all 4 inch or larger sewer services. For laterals larger than 4 inch, a manhole shall be installed at the main line connection.

If abnormal or unusual conditions occur, the City Engineer may vary the pipe materials.

Poly Vinyl Chloride (PVC): All PVC laterals shall conform to ASTM 3034, SDR 26.

(a) Connections:

Connections to PVC SDR 26 sewer mains shall be made with a "wye" fitting, and 1/8 bend.

Ductile Iron Pipe (D.I.P.): All Ductile Iron Pipe shall be Class 50 and shall conform to the current Improvement Standards of the American National Standards Institute (ANSI) - A21.51 – 1976

All Ductile Iron Pipe shall have a polyethylene encasement which shall conform to the current Improvement Standards of the ANSI - A21.5 (AWWA C105-72).

(a) Connections:

Only Cast Iron straight pipe, elbows and fittings shall be used from the sewer main to the right-of-way line. Cast Iron Pipe shall be furnished with "Tyton Joints" or "Ty-Seal Joints". Ductile iron transition couplings shall be installed in accordance with the manufacturer's specification for each pipe size.

When connecting a sewer lateral directly from the manhole to the right-of-way line. Ductile Iron Pipe shall be inserted onto the manhole and brought to the right-of-way line.

#### **4.11 MATERIALS TO BE FURNISHED AND INSTALLED BY DEVELOPER:**

The Developer shall furnish all the labor, materials, equipment, and appliances required to complete the sewer mains and sewer services specified.

#### **4.12 SERVICE INSTALLATION:**

The services shall be installed as per Drawings 4-A & 4-B.

Wye: (For 6-inch VCP main and all Cast Iron or Ductile mains):

- (a) Excavate sewer main to a point 6 inches below required depth.
- (b) Make three (3) initial cuts in the main, 2 to 6 inches apart, and remove the rings. Cut the main to the required length to insert wye or tee.
- (c) Place 6 inches of crushed stone or crushed gravel as per Section 4.10 of these Improvement Standards at bottom of sewer main trench.
- (d) Use shear coupling having stainless steel support band and stainless-steel tightening bands.

Wye Saddles: (For 8 inch or 10-inch VCP mains):

- (a) The City Engineer shall be present during the installation procedure.
- (b) Excavate service trench and expose minimum section of the main.
- (c) Cut a hole of a shape and diameter compatible with the fitting to be installed. Sewer main shall be drilled or saw cut. No chiseling will be permitted. A tee saddle with a collar shall be installed if main is 5 feet or deeper.
- (d) The under surface of the wye and the receiving edge around the hole in the main shall be ground slightly to remove the glaze on the pipe surface, immediately prior to the application of the epoxy.
- (e) Service location to be marked by chiseling an "S" on curb face.

12 inch or larger sewer mains: No direct connections are permitted on 12 inch or larger sewer mains, except in areas specifically designated and approved by the City Engineer. A service lateral may be connected to these mains, upon approval of the City Engineer, using one of the following methods:

- (a) A lateral or fly-line, (Minimum 6 inch), may be extended from an existing manhole to the property, parallel to the main line. The lateral extension shall end in a terminal manhole. The building lateral shall be connected from the lateral extension to the right-of-way line. Improvement plans of the lateral shall be prepared by a Civil Engineer and shall be submitted to the City Engineer for approval.
- (b) If no manhole exists immediately adjacent to the property, a manhole may be placed over the main.
- (c) If a manhole exists immediately adjacent to the property, the building lateral may be connected directly from the existing manhole to the right-of-way line.

#### **4.13 BACKFILL:**

In undeveloped streets, after the sewers and appurtenances have been properly constructed and inspected., the trench shall be backfilled and compacted as shown in Drawing 7-A and shall conform to Section 19-3.06 of the current State Standards. The pipe shall be shaded by hand shovel method, 1 foot over the pipe, where clods exist in the spoil pile which may damage the pipe in the opinion of the City Engineer. Above this hand shading, all clods of any kind shall be removed which are larger than 4 inches in diameter.

Ponding and jetting are not allowed.

In existing paved streets, Class 1 aggregate sub-base conforming to Section 25-1.02A of the current State Standards, shall be used as the backfill material where a sewer wye is installed on an existing main. Ponding or jetting will not be allowed in existing paved streets.

Compaction testing shall be the Developer's responsibility.

**4.14 INSPECTION:**

All sewer lines shall be inspected for proper installation by the City Engineer prior to backfilling of trenches. Inspection of sewer lines shall include an air test, mandrel test, and television inspection. Inspection to be conducted after curb, gutter and sidewalk is installed and 80% of road base has been installed and compacted.

Air Test: Manhole to Manhole, 3.5 psi. for 3 minutes.

Mandrel: 5% mandrel (must be certified)

TV: Allowable Deflection:

8"	1"
10"	1 ¼"
12"	1 ½"

If work is to be completed after normal business hours, contractor shall call (209) 845-3625 to arrange for an inspection to be made after normal business hours. Work shall not be covered without inspection.

When pavement is cut to install a sewer lateral perpendicular to the main and the work cannot be completed within one day, a steel plate shall be placed over the open trench and safety precautions shall be followed as required in Section 6 Safety. The trench shall not be backfilled until the work has been inspected by the City Engineer, see Section 1.6 of these Improvement Standards, and Cal-OSHA Standards.

Prior to backfilling of trenches, the City Engineer may test for fractures and / or cracks in the pipe using a dye recommended by the pipe manufacturer and supplied by the City. All fractures and / or cracks in the pipe, shall be repaired by the Developer and re-inspected by the City Engineer, at Developer's expense.

The City Engineer will inspect all new lines with closed circuit television. The Developer shall give the City Engineer at least 2 working days' notice prior to performing the work, at the Contractor's expense.

The Developer shall clean all lines of dirt and other debris, clean manholes, remove broken pipe, compact trench, raise manhole rims to grade, and correct all visible infiltration, leaks, and deficiencies prior to inspection. Areas adjacent to manholes shall be leveled and made accessible to the television trailer. All inspections, including repeat work because the lines have not been cleaned, will be charged to the Developer on based on the time of the crew and equipment.

The Developer will have access to the television log sheets and to any pictures taken of the work. The Developer shall repair all substandard work discovered by the TV camera. Developer shall give the City Engineer at least 2 working days' notice prior to performing the work.

**4.15 GREASE TRAPS:**

Grease Traps and Interceptors shall be constructed by the Developer on private property, on the sewer service lateral for any facility whose operation will result in oil, grease, sand or other solids being discharged into the City's sanitary sewer or storm drainage system.

The Traps or Interceptor shall conform to Section 708 and 711 of the current Plumbing Code adopted by the City and it shall be constructed where it can be easily inspected for proper operation by the City Engineer.

END OF SECTION

## 5. STORM DRAIN

---

### 5.1 GENERAL:

These Improvement Standards cover storm drainage facilities to be constructed in the public right-of-way. The drainage system shall be by drywell or by positive collection system discharged into a natural waterway (positive drainage). These Improvement Standards also specify how and when private property may discharge into the public storm system.

Where storm drain trunks are available, the Developer shall design a drain collection system to discharge into the storm drain trunks or, if approved by the City Engineer, the Developer may also design the trunk line for discharge into a natural waterway.

Where no storm drain trunks are available, the Developer shall utilize the "2015 Post-Construction Standards Plan" for design guidance. Alternatives to positive drainage shall be reviewed on a case-by-case basis. In general, the City prefers site treatment control measures of retention or detention basins, see Table 3 "Site Design and Treatment Control Measures" of the Post-Construction Standards Plan.

In these Improvement Standards, storm drain trunks are 42" inches and larger. Other storm drains are referred to as laterals.

### 5.2 DESIGN OF POSITIVE DRAINAGE:

Positive storm drainage shall be designed using the "Rational Method", with the following values of the parameters applied in the equation  $Q = CIA$ :

$C = 0.40(*)$  for residential (R-1, R-2)

$C = 0.80(*)$  for all other areas

$I$  = Intensity in inches, per hour taken from the 10-year frequency curve shown in Drawing 5-G.

(\*) The C-values listed are considered to be average runoff coefficients. Allowances for different C-values may be made upon approval of the City Engineer and shall be determined by the design of the improved areas.

The area, "A" in the above equation is the contributing area in gross acres, and the flow, "Q" is in cubic feet per second.

The minimum pipe flow velocity shall be 2 feet per second, with an "N" value of 0.013 for concrete pipe and an "N" value of 0.011 for PVC pipe when using "Manning's Formula".

The minimum pipe size shall be 12" inches inside diameter for lines providing drainage of public right-of-way. Private service lines may be smaller, but they are to be maintained by the property owner.

The time of concentration on a lot shall be 20 minutes, unless otherwise approved by the City Engineer.

### 5.3 DISCHARGE STRUCTURES:

Discharge structures designed by the Developer shall be submitted for approval by the City Engineer.

It shall be the responsibility of the Developer to obtain written approval and encroachment permits from any agency controlling the discharge of drainage into the natural waterway or receiving waters.

### 5.4 RESERVED

## 5.5 DRAINAGE BASINS:

Drainage basins must be approved by the City Council and designed to meet the requirements of the City Engineer.

The basic requirements for all storm drainage retention and detention facilities are as follows:

- (a) Retention and detention facilities shall be designed using a 100-year, 24-hour storm, with a rainfall intensity of 2.88".
- (b) The volume of the detention basin shall be large enough to entrap a total of 3.10 inches of water over the area developed.
- (c) The volume of the retention basin shall be large enough to entrap a total of 4.65 inches of water over the area developed.
- (d) All basins shall include rock wells or horizontal drains.
- (e) The maximum high water line elevation of the basin shall be 6 inches below the lowest gutter elevation.
- (f) The maximum basin water depth shall be 10 feet and the bottom shall be shaped to concentrate the water at the inlet.
- (g) Basin shall be designed such that the total volume of water (see part a) shall percolate or be discharged within 48 hours.
- (h) Side slopes shall be 4H:1V maximum.
- (i) Access roads shall be provided for access to drywells by city maintenance crews.

Other requirements for safety, aesthetic and special conditions may be imposed by the City Engineer.

For retention and detention basins, for any design standards or details not contained herein, see Stanislaus County current standards and details. Final design to be approved by the City Engineer.

## 5.6 PIPE MATERIAL:

Storm drain pipe may be Reinforced Concrete Pipe (RCP) or Polyvinylchloride (PVC) SDR-26. Use of high-density polyethylene (HDPE) pipe must be approved by the City Engineer.

The type of pipe used must conform to accepted Engineering practice and must be approved by the City Engineer. The class of pipe to be used shall be shown on the plans or specified in the special provisions.

Reinforced concrete pipe shall conform to Sections 65-1.02, 65-1.02A, 65-1.03, 65-1.06, 65-1.07 and 65-1.08 of the current State Standards.

## 5.7 CATCH BASINS:

Catch Basins (in Curb & Gutter), shall be constructed as shown in Drawing 5-A. Pipe Inlets (in Valley Gutters) shall be constructed as shown in Detail 5-B.

## 5.8 MANHOLES:

Storm drain manholes shall be constructed on storm drain trunk lines and lateral lines as shown in Drawing 5-C. Storm drain manholes for lines greater than 36" in diameter shall be constructed as shown in Drawing 5-D.

The manhole castings shall be raised to finish street grade by the Developer. In easement areas, the casting grade shall conform to the surrounding surface unless special elevations are required because of irrigation or future street grades. Castings in undeveloped areas shall have finished concrete pad 48" x 48".

Manholes shall be constructed at changes in horizontal alignment or slope, at intersections of trunks or laterals, at drain inlet connections, at 500 foot maximum spacing, unless greater spacing is approved by the City Engineer, and at all storm drain ends.

#### **5.9 EXCAVATION:**

Excavation shall include the removal of all materials encountered. All trenches shall be excavated in open cut following neat parallel lines equidistant from the centerline as staked. No tunneling or jacking will be permitted without written permission from the City Engineer.

Maximum width of the trench at the level, of the top of pipe shall not exceed the outside diameter of the pipe barrel plus 24 inches.

Excavation shall be carried at least 4 inches below the grade of the bottom of the pipe in areas where the material is too hard to permit proper bedding. This over-excavation shall be brought to grade with approved material compacted in place. Any areas which do not provide a sound foundation shall be over-excavated as directed by the City Engineer and refilled to grade with approved materials compacted in place. Excess and / or rejected material shall be disposed of by the Contractor.

#### **5.10 LAYING PIPE:**

The pipe shall be laid in conformity with the prescribed lines and grades, which shall be obtained by means of a laser beam or by measuring from a tightly stretched line parallel with the grade and supported on at least 3 points over the centerline of the pipe. The Developer shall field verify the depth and alignment of any existing storm drain line prior to construction. If the existing storm drain line is not exactly as shown on the improvement plans, the Developer shall obtain the approval of the City Engineer before proceeding. All adjustments of pipe to line and grade shall be made by scraping away or filling in and tamping under the body of the pipe and not by blocking or wedging. All pipe shall be laid with bell end upstream and shall be laid upstream from structure.

#### **5.11 BACKFILL:**

After the drain pipe and appurtenances have been properly constructed and inspected, see Section 5.10 of these Improvement Standards, and the joints have set, the trench shall be backfilled and compacted until the relative compaction is not less than 90% to within 24" inches to finish grade or to finish grade in an easement. All material in the remaining 24" inches shall be compacted to 95% relative compaction as shown in Drawing 7-A and shall conform to Section 19-3.06 of the current State Standards.

#### **5.12 SERVICE CONNECTIONS:**

Service connections include lines from drain inlets in the public right-of-way, private lines from drain inlets on private property, and private lines from roof drains of private buildings. All service lines shall connect directly into a storm drain manhole. Storm drain connections to the sanitary sewer system are not allowed.

#### **5.13 TESTING:**

Testing for proper compaction and for control of the concrete shall be as directed and observed by the City Engineer and performed by the Developer unless otherwise specified on the Plans.

Certificates of compliance, weighmaster tags or other standard design data may be required by the City Engineer, in lieu of testing for proper concrete design.

On subdivision projects, the cost of the above testing shall be at Developer's expense.

#### **5.14 INSPECTION:**

The City Engineer will inspect all new lines with closed circuit television or by visual inspection made when crawling through the lines. If the closed circuit television is used, it shall be done at the Developer's expense, and the Developer shall give the City Engineer at least 2 working days' notice prior to performing the work. Allowable deflection shall be 10% of pipe diameter.

The Developer shall clean all lines of dirt and other debris, clean manholes, remove pipe crowns, compact trench, raise manhole rims to grade, and correct all visible infiltration, leaks, and deficiencies prior to inspection. Areas adjacent to manholes shall be leveled and made accessible to the television trailer. All inspection and equipment time will be charged to the Developer on subdivision projects.

The Developer may have access to the Television Log Sheets and to any pictures taken of the work. The Contractor shall repair all substandard work.

If work is to be completed after normal business hours, Contractor shall call (209) 845-3600, to arrange for an inspection to be made after normal business hours. Work shall not be covered without inspection, see Section 1.6 of these Improvement Standards.

END OF SECTION

## 6. SAFETY

---

### 6.1 GENERAL:

The Safety Section is intended to establish general principals of traffic control, worker protection and public safety measures to be taken in the performance of all work covered by these Improvement Standards.

No specification contained herein shall be deemed to create a legal standard of conduct or duty toward the public nor shall it limit the City in the exercise of powers conferred by law in modifying these specifications under special conditions.

The requirements of the State Traffic Manual and CA-MUTCD shall take precedence over the requirements of this Safety Section.

### 6.2 TRAFFIC CONTROL:

The safe movement of traffic through construction areas depends upon communicating concise and proper information to the public by signs, barricades, delineators, flagmen and warning lights. All such devices necessary during construction shall be furnished by the Developer. The size, shape, and color of such devices shall be as required by CA-MUTCD.

A Traffic Control Plan may be required at the discretion of the City Engineer. Such plan shall be approved by the City Engineer prior to construction.

### 6.3 SIGNS:

Warning signs used for night time conditions shall be reflectorized or illuminated. The use of orange flags in conjunction with signs is permitted if they do not at any time interfere with a clear view of the sign face.

Reflectorized signs fastened to barricades or similar supports shall have the face of the sign vertical and normal to the direction of traffic for effective visibility.

Signs are to be used only as long as necessary and then removed. During periods when the signs are temporarily unnecessary, they shall be removed or have their message covered.

### 6.4 BARRICADES:

Barricades are intended to impose an obstacle in or close off the normal flow of travel. Approved barricades for street closures are shown on Drawing 6-D. Approved barricades for pavement width transitions are shown on Drawing 6-E. Barricades shall not be used unless they are needed to separate the motorist from objects of greater hazard than the barricades themselves. Barricades should never be used primarily for delineation. The use of non-standard types of barricades, such as drums, buckets, sandbag, etc., can be hazardous and their use is prohibited.

### 6.5 FLASHER SUPPORTS:

Portable flasher supports shall be as required by the State Traffic Manual.

### 6.6 DELINEATORS:

The function of delineators is to channelize traffic. They shall consist of post and paddle type markers or cylindrical or cone shaped objects 18 to 48 inches in height as shown in CA-MUTCD.

Delineators should be uniformly positioned laterally and longitudinally relative to the line of traffic and they must be maintained in an erect position.

Delineators for night time use shall be reflectorized or illuminated to be visible from 500 feet under normal atmospheric conditions.

When placed in proximity to the edge of a traffic lane, delineators should be made of a material that will withstand impact without damage to them or the striking vehicle. Consideration must also be given to the necessity for stability against knockdown from wind or from the wash of passing traffic.

#### **6.7 FLAGMEN:**

Flagmen shall be required as necessary for safe conduct of the traffic through the construction area or as directed by the City Engineer. Flagmen shall not be used as a substitute for other warning signs and devices. Standard hand signals shall be used as shown in the CA-MUTCD.

#### **6.8 WARNING LIGHTS:**

Warning Lights shall be electric lanterns, electric markers or flashers, provided to indicate an obstruction or restriction during periods of low visibility. Warning Lights shall be placed to mark the location of obstructions. Motion may be imparted to Warning Light.

Flashing Lights for delineating the path traffic is to follow shall be uniformly spaced as approved by the City Engineer.

Warning Lights may be fastened to signs, barricades and portable flasher supports in a manner satisfactory to the City Engineer.

#### **6.9 STREET CLOSURES:**

Partial temporary street closures shall be made as shown in the State Traffic Manual. Prior to any street closure on a collector or major street, a Traffic Control Plan shall be approved by the City Engineer. In addition, a copy of the approved Traffic Control Plan shall be on the site at all times. One lane for each direction of through traffic must be maintained except where flagmen are provided to control traffic, then one lane may serve both directions. When trenching is necessary across intersecting streets, the work shall be done in such a manner as to maintain two-way traffic on cross streets at all times.

Where the trench line crosses an entrance to private property, access to the property shall be maintained at all times by means of a suitable bridge, until the trench may be backfilled. Such bridges shall be properly guarded and illuminated at night. Where any crosswalk is cut by the trench, suitable bridging shall be constructed. Such bridging shall be at least 4 feet in width, shall have suitable hand railing, shall be properly guarded and illuminated at night and shall be made immediately in cases where backfill material is suitable for jetting. The City Engineer shall determine which backfill material is suitable.

The complete closure of a street is allowed only when authorized in writing by the City Engineer as provided by these Improvement Standards. Such closure shall be accomplished only through the use of Type III Barricades as shown in CA-MUTCD.

Permanent closures and temporary closures in new developments at dead end streets shall conform to Drawing 6-D.

#### **6.10 RULES AND REGULATIONS:**

All work performed and all materials used by the Developer shall comply with the following: the State Labor Code; the California Administrative Code, Construction Safety Order, Title 8, Subchapter 4; all other applicable Federal, State and Local laws and regulations.

Specifically, the Developer shall furnish; install and maintain all shoring, bracing and sheeting. Any damage resulting from a lack of adequate shoring, bracing or sheeting shall be repaired at the Developers' or City Contractors' expense.

Additional requirements may be imposed by the City Engineer in the interest of public safety.

### **6.11 UNDERGROUND SERVICE ALERT - USA NORTH:**

The Developer shall call USA North at 811/800-227-2600 at least 48 hours prior to the start of any excavation, within the City Limits. All participating members, including the City of Oakdale, will be informed by USA North of the location, date, time and description of the proposed excavation.

Any existing underground facilities will then be located and marked in the field by the appropriate USA North member organization(s). Requests for field meetings shall be included in the initial call to USA North. For further information, contact the City of Oakdale at 1-209 845-3600 (Fax 1-209-848-4344). All excavation shall be in compliance with Section 1540(a) (1) of the Construction Safety Orders (Title 8, California Administrative Code Section 1540), which states:

" Prior to opening an excavation, effort shall be made to determine whether underground installations; i.e., sewer, water, fuel, electric lines, etc., will be encountered and, if so, where such underground installations are located. When the excavation approaches the approximate location of such an installation, the exact location shall be determined by careful probing or hand digging; and, when it is uncovered, adequate protection shall be provided for the existing installation. All known owners of underground facilities in the area concerned shall be advised of proposed work at least 48 hours prior to the start of actual excavation."

The Developer shall be responsible for the preservation of, and repairing any damage to, both private and public property in accordance with current State Standards.

END OF SECTION

## 7. UTILITIES

---

### 7.1 GENERAL:

These Improvement Standards are intended to establish uniform locations and construction procedures for all underground utilities.

### 7.2 ENCROACHMENT PERMITS:

All utilities shall obtain an encroachment permit prior to commencement of work. The request shall be accompanied by a plan showing location and sizes of all underground work in existing right-of-way and easements including new subdivisions and parcel splits. The encroachment permit must be obtained from the City Engineer prior to commencement of work.

Emergency or repair work may be done prior to obtaining a permit by calling "Engineering Division at (209) 845-3600", and giving them the location, contractor and circumstances of work required within the City of Oakdale right-of-way. Any work within the State right-of-way will require a Caltrans encroachment permit.

### 7.3 BACKFILLING OF TRENCH:

The trench shall be backfilled and compacted as shown on Drawing 7-A, and shall conform to "Section 19-3.06 of the current State Standards". Alternate cementitious backfill material may be used with prior approval of the City Engineer.

In undeveloped streets, ponding or jetting will be permitted when specifically approved by the City Engineer, if this method does not hinder subsequent operations. Ponding or jetting will not be allowed in existing paved streets.

Except where otherwise specified, initial backfill material shall be sand, gravel, crushed aggregate or native free-draining material. If, in the opinion of the City Engineer, the native material is unsuitable for initial backfill, the City Engineer may require the Developer to test the native material, at the Developer's expense. In order to be considered suitable, the native material shall have a sand equivalent of not less than 30 or having a coefficient of permeability greater than 1.4 inches per hour. The initial backfill shall be free of rocks or clods greater than 3 inches in diameter and shall be free of organic or other unsuitable material.

All native backfill material shall be free of rocks and clods greater than 3 inches in diameter and free of organic or other unsuitable material.

In the event that select native or native backfill material as defined by this section is not available in the trench spoils, material shall be imported to meet the requirements of this section.

### 7.4 TRENCH PAVEMENT:

All trenches shall be paved as per Drawing 7-A.

### 7.5 TEMPORARY TRENCH PAVEMENT:

When paving replacement of trench is to be done by the City of Oakdale, Contractor shall backfill the trench with aggregate base. Temporary pavement, 3 inches thick, shall be installed on top of the aggregate base.

### 7.6 INSPECTION:

Inspection of the utility work shall conform to the requirements of the encroachment permit and these Improvement Standards.

Additional inspections shall be requested by the utilities, Developers and City Contractors whenever damage to another utility occurs.

### **7.7 IRRIGATION LINES:**

Existing cast-in-place irrigation lines in street right-of-way shall be replaced with reinforced concrete pipe conforming to "Sections 65-1.02A and 65-1.-6B of the current State Standards".

The pipe shall be Class III except where the cover to finish grade is less than 3 feet, the pipe shall be Class IV.

Irrigation lines to be abandoned shall be removed, and not crushed and left in place.

Irrigation lines within a subdivision shall be removed, protected or relocated as required by the "Oakdale Irrigation District" and the City Engineer. Appropriate easements for irrigation lines to remain shall be dedicated as necessary. If required, a release of irrigation rights shall be executed by the "Oakdale Irrigation District".

### **7.8 TRENCH MAINTENANCE - MAJOR PROJECT:**

The Developer, City Contractor or Utility shall inspect and repair work done on the trench for a period of 1 year from the date the work is accepted as complete by the City Engineer or, if subsequent repairs as required, 1 year from the date the repairs are complete.

### **7.9 UNDERGROUND SERVICE ALERT - ALL PROJECTS:**

The Developer, City Contractor shall call "Underground Service Alert North", two working days before you dig. By calling CA/NV 1-811/800-227-2600, for all projects by the City of Oakdale. The Developer shall outline the proposed excavation with white paint. Call 6:00 AM - 7:00 PM, Monday through Friday except holidays.

END OF SECTION

## 8. LIGHTING

---

### 8.1 GENERAL:

Street lighting shall be installed to conform to these Improvement Standards by a Developer holding an appropriate license for such work under the provisions of the State of California Business and Professions Code. In the development of the plans, the City Engineer shall be consulted to insure coordination with utility provider (PG&E or MID) and the Improvement Standards.

Electrical equipment shall conform to the requirements of the National Electrical Manufacturers Association and material and work shall conform to the requirements of the National Electrical Code, the Electrical Safety Orders of the Division of Industrial Safety, Department of Industrial Relations of the State of California; rules for Overhead Line Construction G.O. 95, State of California, Public Utilities Commission, the Standards of the American Society for Testing Materials and the American National Standards Institute.

### 8.2 DESIGN:

The lighting system shall be designed to best serve the area and to minimize the length of service runs from the points of connection to the street lights.

All street lights to be installed shall be shown on the improvement plans. The location of the power source and of all conduit runs shall be shown on the improvement plans.

The circuit lengths and conductors shall be sized such that the maximum voltage drop between the source and any street light does not exceed 5 percent of the nominal circuit voltage.

### 8.3 CONDUIT:

Conductors shall be run in P.V.C. conduit except when run inside poles. Conduit and fittings shall be rigid metal or intermediate metal in locations, where approved by National Electrical Code, 1-inch minimum diameter. All fittings installed in concrete shall be of the concrete tight type.

Conduit shall be Sch. 40 P.V.C. between pull boxes, zinc-coated at the shearding, hot-dip or electro-plating process, from pull box to pole. Each length shall bear the label of the Underwriters Laboratory, Inc.

Conduits shall be bonded together in pull boxes and pole bases with no less than No. 8 AWG copper wire.

Where factory bends are not used, conduit shall be bent without crimping or flattening, using the longest radius practicable. In no case shall the bend radius be less than six times the inside diameter of the conduit.

Conduits crossing a paved right-of-way, shall be installed by the jacking or open trench method and shall be installed 30 inches below top of grade.

### 8.4 CONDUCTORS:

Conductors shall be No. 10 copper or larger, THW single conductor, Underwriter Laboratory approved. Wires within poles shall be No. 10 solid.

No conductors shall be drawn into the conduit until the conduit run is complete and the conduit is free of debris. If the conduit is installed in a pole foundation, the conductors shall not be drawn into the conduit for at least 3 days after placement of the foundation concrete.

Conductors shall not be spliced except in pole bases (or in pull boxes when approved by the City Engineer). The splices shall be made as follows:

- (a) Where specifically approved by the City Engineer, spliced in pull boxes shall be made using Ilson IK8 10 STP-8STP split box bolt to connect wire ends. Split bolt shall be wrapped first with Plymouth Bishop 122

Rubber Tape (splicing compound) #2002 and then with 3M "33+" electrical tape. The entire splice shall be coated with 3M "Scotchkote" electrical coating.

### **8.5 PULL BOXES:**

Pull boxes shall be size Christy N-30 concrete and shall be furnished by the Developer. A pull box shall be installed at the base of the street light standard, per Drawing 8-B.

Where a utility company transformer is designated as the service point, a pull box shall be installed adjacent to the transformer and at street light standard.

Additional pull boxes shall be installed in conduit runs as necessary so that no conduit run shall exceed 200 feet between pull boxes.

Traffic lids shall be used when pull boxes are placed in areas travelled by vehicles. The traffic lids shall be 1/4" inch galvanized steel plate with 1/2" inch diameter lift hole and bolt holes to match standard stud bolts. All pull box lids shall identify the circuit as Street lights, Traffic Signals, etc.

### **8.6 FOUNDATIONS:**

Foundations for poles shall be constructed of concrete as shown in Drawing 8-A.

Foundations shall be placed monolithically to within 4" inches of sidewalk grade. After the light pole is installed, a 36-inch square cap shall be placed to bring the foundation to sidewalk grade.

In areas of reconstruction, all work on foundations must conform to Section 15-2.05, 86-2.01, 86-2.02 and 86-2.03 of the current State Standards. Sidewalk grade may be lowered a maximum of 2" inches. In no Case shall the base of the standard be permitted to be more than 2" inches above grade. Where the new grade will be higher than the original established grade, the standards may be raised as permitted by unused threads on the anchor bolts. In all cases, a full nut of threads must be maintained. Welding shall not be performed on the body of high strength anchor bolts. Base of standards may never be left below grade. Where these standards cannot be met, a new pole foundation must be installed.

Foundations shall include a concrete-encased grounding electrode complying with Article 250-81(c) of the National Electrical Code.

### **8.7 ANCHOR BOLTS:**

Anchor bolts shall be 1-inch in diameter, 40 inches long with a 4-inch "L" bend at the bottom end. Anchor bolts shall conform to ASTM Designation A 307.

### **8.8 POLES:**

Poles shall be hot-dipped galvanized steel. Twenty-eight (28') foot poles with 15' foot arms shall be Ameron Catalog No. N-2815-2. Twenty-five (25') foot poles with 15' foot arms shall be Ameron No. N-2515-2 or an approved equal. Pole tops and base covers shall be furnished and installed with each pole.

Poles shall not be installed until the foundation has set at least five (5) days. Poles shall be plumbed by adjusting the leveling nuts; leveling shims shall not be used. The poles shall be grounded to conform to the provisions of the National Electrical Code.

Poles shall have hand-holes near their bases.

### **8.9 ELECTROLIERS:**

The electroliers shall be located according to size as shown in Drawings 8-A & 8-B.

Luminaires shall have L.E.D. lamps, glass refractors, built-in receptacles for photoelectric cells, and regulator or auto-regulator type ballasts with a power factor of not less than 92%.

### **8.10 PHOTOELECTRIC CELLS:**

Photoelectric cells shall be compatible with related equipment and adequate for the load.

### **8.11 EXCAVATION:**

The trench excavation shall be made by the Developer as shown in Drawing 8-D. Trenches shall be straight and of even depth. Special locations or depths must be approved by the City Engineer prior to excavation.

### **8.12 LAYING CONDUIT:**

The conduit shall be laid in the trench as shown in Drawing 8-D. Wherever possible, the conduit shall be placed adjacent to sidewalk for protection from future excavation. Conduit shall be jacked at existing street crossings.

### **8.13 BACKFILL:**

The backfill shall be compacted as shown in Drawing 8-D.

### **8.14 WOODEN UTILITY POLE MOUNTING:**

Existing wooden utility poles shall not be used for mounting lights unless specifically directed by the City Engineer and permitted by the Owner of the pole. Where approved, brackets for street lights mounted on wooden utility poles shall be Ameron Catalog No. 961-15N2.

### **8.15 CONNECTION TO ELECTRICAL DISTRIBUTION SYSTEM:**

Where lighting circuit and energy source meet, the circuit shall terminate in the utility provider's service box or pull box. The circuit shall terminate with a Bussman TRON fuse-holder, with 30 Amp cartridge fuse, type HEB-AB. The fuse shall be taped to the cable and there shall be 4' feet of slack conductor coiled in pole.

Developer shall furnish and install conduit and conductors from pull box into the utility provider's transformer. Entrance into the utility provider's transformer shall be coordinated with, and supervised by the utility provider.

The connection to either an overhead or underground energy source will be made by the utility provider, upon receipt of request for service by City. All necessary wiring, conduit, etc. to an existing and available power source shall be installed prior to acceptance by the City. Request for service is made upon completion of work by Developer or upon development of adjacent property.

When a light is to be mounted on a wooden utility pole, Developer shall furnish all materials as specified herein, including all conduit, conductors, thru bolts, lag bolts, etc. for installation by City or the utility provider. The cost for installation shall be included in the cost for inspection of improvements.

### **8.16 TESTING:**

The street lights on City Contract Projects shall be tested in normal service for 4 nights before acceptance by the City.

**8.17 CONFLICT WITH UTILITIES:**

Developer shall be responsible for contacting other utilities to determine that locations for foundations and conduit runs are clear.

Where conflicts exist, the locations may be altered with approval of the City Engineer.

END OF SECTION

## 9. LANDSCAPING

---

Reserved for Future Landscaping Specifications.

## 10. SITE IMPROVEMENTS

---

### 10.1 PURPOSE:

The purpose of this section is to address issues relating to on-site improvements of private development projects, such as commercial and industrial developments, schools, churches, and other uses that include site improvements that are used by the general public (parking lots, etc.).

### 10.2 PARKING:

Parking lot configurations (stall width and depths, aisle widths, etc.) shall comply with Drawing 10-C.

### 10.3 TRASH ENCLOSURES:

Trash enclosures shall comply with Drawing(s) 10-D, 10-E, and 10-F.

All solid waste facilities serving commercial developments must comply with current state regulations regarding recycling (See CalRecycle for details).

### 10.4 DRYWELLS:

Drywells may only be utilized in special circumstances, with special request submitted and pre-approval by the City Engineer.

Drywells shall comply with Drawing 10-A and 10-B. Developer shall submit calculations prepared by a licensed engineer demonstrating that proposed drywells meet the flow and storage requirements of Section 10.4 of these Improvement Standards.

Drywells constructed on private property at vertical curb and gutter shall be installed per Drawing 10-A. Drywells otherwise located on private property shall be constructed as shown in Detail 10-B. Drywells shall be located at least 150 feet from domestic water wells.

Drywells shall extend to 50' feet. Drywells shall not be installed in areas where high groundwater conditions exist. At least 5 feet separation must be maintained between the bottom of the drywell and the seasonal high groundwater as determined by a geotechnical engineer.

The maximum area drained into one drywell shall be 12,000 square feet. The maximum volume drained into one drywell shall be 3.65" of water for the total maximum area. Double drywells shall drain a maximum of 16,000 square feet, and they shall be separated by a minimum horizontal distance of 20' feet.

Developers shall submit boring logs in the near vicinity of proposed drywells to a depth of 60 feet. Percolation rates shall be tested for the soils. These boring logs and rates shall be submitted to the City Engineer for review and approval.

Provision shall be made by means of street geometric design to minimize the overflow of one drywell service area into adjacent areas. Where possible, the Street geometric design shall be such that overflow from a drywell service area into adjacent areas shall only occur for storms with a return frequency of greater than 5 years.

Where a drywell service area is designed to overflow into adjacent areas, the Developer shall provide drainage facilities in the adjacent areas to dispose of the additional runoff. The drainage facilities in the adjacent areas shall be as approved by the City Engineer.

Drywells shall be tested for adequacy after completion of all work in their designed service area. Testing shall consist of flooding the drywell at a rate equal to its design percolation for a duration equal to the Peak Flow Time. If a static head is obtained, then the rock well shall be allowed to drain for 1 hour, then refilled and its percolation rate then calculated. The measured percolation rate of the rock well shall be compared to the

design percolation rate. If the measured rate is less than the design rate, additional percolation area will be required. Drywells are required to absorb the total design volume within 24 hours.

It is the Developer's responsibility to adjust the drywell or add more drywells until the test is approved by the City Engineer. Testing shall be done under the direction of the City Engineer and at Developer's expense.

The Driller or Developer shall submit to the City Engineer a well drilling log as soon as possible after drilling is completed and prior to acceptance of the improvements by the City Engineer. Rock shall conform to the gradation of current State Standards, Section 90: Portland Cement Concrete, is amended and included in the project Special Provisions.

The corrugated metal pipe may be either corrugated aluminum pipe or corrugated galvanized steel pipe. The pipe shall conform to the requirements of Section 66-1.02 of the current State Standards.

The drywell frame and cover shall be as shown in Drawing 10-A and 10-B.

END OF SECTION

## 11. FIRE

---

### 11.1 PURPOSE:

The purpose of this section is to address issues relating to fire suppression within private development projects, such as commercial and industrial developments, schools, churches and other buildings used by the general public.

### 11.2 PRE-FIRE PLANS

Pre-fire plans shall be submitted and include the following information (see Drawing 11-B, 11-B-1, and 11-B-2 for requirements and symbols):

#### A. SITE PLAN:

A Site Plan (11"x17") shall be submitted that includes the following information:

- (1) Building Address
- (2) Cross streets
- (3) Hydrants
- (4) North Reference Arrow
- (5) Access and Egress (Driveways, Gates, Etc.)

#### B. BUILDING FLOOR PLAN:

A Building Floor Plan (11" x17") shall be submitted that includes the following information:

- (1) Main entrance and lock box
- (2) Each floor layout
- (3) Entrances and exits
- (4) Room #s, Apt #s, Suite #s
- (5) Area and occupancy, separation walls
- (6) Utilities
- (7) Fire alarm control unit location
- (8) Fire system, FDC, main valve, test valve, rise location
- (9) Attic access, roof ladders etc.
- (10) Hazardous material location
- (11) Any other fire protection, system hood, CO2
- (12) Air condition units
- (13) Stairs
- (14) Elevators

### 11.3 ALL WEATHER ACCESS ROAD

PLANS: Plans for "Fire Apparatus Access Roads" shall be submitted to Fire Department for review and approval prior to construction.

REQUIRED ACCESS: "Fire Apparatus Access Roads" shall be provided for every facility, building or portions of a building hereafter constructed or moved to within the jurisdiction when any portion of the facility or any

portions of an exterior wall of the first story of the building is located more than 150 feet from the fire apparatus access as measured by approved route around the exterior of the building or facility.

FIRE ACCESS REQUIREMENTS (FOR BUILDING CONSTRUCTION) Residential subdivisions require finished paved roads per city standards with fire hydrants, blue markers, and street signs installed before vertical construction may begin.

The City of Oakdale requires that a fire hydrant be in service within 250 feet of the furthest point of construction prior to the stockpiling of combustible materials or the beginning of combustible construction.

Temporary all weather construction phase Fire Department access route structural sections shall consist of a minimum of 12 inches of base rock material over either (1) a lime treated subgrade, or (2) a subgrade covered with fabric in accordance with the following design criteria:

1. Subgrade is defined as the native soil at the bottom of the access route structural section, excavated to the lines and grades shown on the project grading plan, and provided with a discharge for the collected storm water runoff, as approved by the City Engineer.
2. Base rock shall be class II aggregate base compacted to at least 95% relative compaction.
3. Base rock shall be placed only on a firm and unyielding (compacted to at least 95% relative compaction) excavated and drained subgrade.
4. Lime treated subgrades shall be designed in accordance with the recommendations of a geotechnical engineer and compacted to at least 95% relative compaction.
5. Fabric shall be a ground stabilization fabric such as Mirafi 600X or equivalent.
6. Fire Department access shall be a minimum 26 feet in width and provided so that a 150-foot length of hose can be extended from the parked fire vehicle to all points along the exterior perimeter of all structures.
7. Alternate all weather access road sections may be proposed by a geotechnical engineer and submitted to the Public Services Director for approval. Approval of the Public Services Director and Fire Code Official is required for alternate all weather access roads.

EXCEPTION: When buildings are completely protected with an approved automatic fire sprinkler system, the provisions of this section may be modified by the Fire Chief.

SPECIFICATIONS: Dimensions: "Fire Apparatus Access Roads" shall have an unobstructed width of not less than 26 feet and an unobstructed vertical clearance of not less than 13 feet by 6 inches.

EXCEPTION: Upon approval by the Fire Chief, vertical clearance may be reduced, provided such reduction does not impair access by fire apparatus and approved signs are installed and maintained including the established vertical clearance.

SURFACE: "Fire Apparatus Access Roads" shall be designed and maintained to support the imposed loads of fire apparatus and shall be provided with a concrete or asphalt surface so as to provide all weather capabilities. The surface must be engineered and be capable of supporting a 37.5 ton (75,000 pound) imposed load.

EXCEPTION 1: Temporary construction roads may be approved by the Fire Chief so long as they are engineered to support the 37.5-ton load. This basically requires a 95% soil compaction (tests required) and 2-3 inches of roadbed.

TURNING RADIUS: The turning radius of a fire apparatus access road shall be as approved by the Fire Chief. "Dead Ends, Fire Apparatus Access Roads" in excess of 150 feet in length shall be provided with approved provisions for the turning around of fire apparatus, see Drawing 11-C.

BRIDGES: When a bridge is required to be used as access under this section, it shall be constructed and maintained in accordance with the applicable section of the California Building Code and shall use designed live loading sufficient to carry the imposed loads of fire apparatus.

GRADE: The gradient for a fire apparatus access road shall not exceed 12% (except for short distances 10'-15') Where required, anything over 15% shall have a concrete or asphalt surface, and within thirty feet of the grade transition to less than 12%.

OBSTRUCTION: The required width of a fire apparatus access shall not be obstructed in any manner, including parking of vehicles. Minimum required width and clearances established under this section shall be maintained at all times.

The installation, maintenance and upkeep of the fire apparatus access roads, or any utility for the maintenance of the roadway is the responsibility of the Developer, Property Owner, Homeowners' Association, or Occupants within the Development.

MARKING: When required, approved signs or other approved notices shall be provided and maintained for fire apparatus access roads to identify such roads and prohibit their obstruction.

#### **11.4 PREMISES IDENTIFICATION**

This standard is promulgated for the purpose of clearly identifying and marking proper addresses pursuant to "California Fire Code" adopted by the City of Oakdale.

ADDRESSING:

1. Approved numbers or addresses shall be placed on all new and existing buildings above the doorway or in such a position as to be plainly visible and legible from the street or road fronting the property.
2. The minimum size dimension of the numbers shall be identified below.
3. Numbers shall be in contrasting color to their background.
4. Where a building is set back from the street or road fronting the property and where addresses may not be clearly identifiable due to distance from the street or roadway, landscape and architectural appendages, or other obstructions, address posting shall be required both at the street driveway serving such building and on that building.
5. Directories: For complexes with multiple buildings and large buildings, a directory, premises map, and directional signs may be required at approved locations. When deemed necessary by the Fire Chief, these signs, maps, etc. shall be illuminated.

6. Requirements for Construction: When required by the Fire Chief, approved street name sign and address numbers at the site shall be installed prior to construction of any new structure.
7. Requirements for Occupancy: Prior to occupancy of any new structure, address numbers on the building, directories, premise maps, and directional signs shall be installed.

REQUIREMENTS:

One- and Two-Family Dwellings, and Mobile Homes: Building address shall be a minimum of four (4) inches, contrasting in color to the background, internally illuminated, and readily visible from the street. No brass or gold-colored numbers are allowed. Where structures are set back from the street, larger numbers may be required. In the event a structure is not visible from the street the address numbers shall be posted adjacent to the driveway entrances as well as on the structure. The posted numbers on the driveway entrances may be non-illuminated at the discretion of the Fire Chief.

A plan shall be submitted to the Oakdale Public Services Department for review indicating the method in which buildings are to be identified by address numbers.

Townhouses, Condominiums: Building address numbers shall be a minimum of six (6) inches in height, contrasting in color to the background, internally illuminated and readily visible. No brass or gold-colored numbers are allowed.

Each individual unit number shall be above or adjacent to the entrance door. Numbers shall be four (4) inches in height, contrasting in color to the background, internally illuminated and readily visible. No brass or gold-colored numbers allowed.

Address directory maps shall be provided showing all streets, driveways, building numbers and any additional information that would assist in locating individual units. See Directory Map requirements.

Numbering Order for Multi Occupancies

- (1) Single story buildings shall be identified by using alpha characters starting with "A" ending with "Z". The numbering sequence shall be in a clockwise direction beginning at the main street address entrance. Each individual building shall identify suites or apartments by using numbers starting with one (1). The numbering sequence shall be in a clockwise direction.
- (2) Multi-story buildings shall be numbered by floor series. First floor 100-199, Second floor 200-299, Third floor 300-399. The numbering system shall be in a clockwise direction starting at the main entrance.\

REQUIREMENTS:

These standards shall apply to all apartments, commercial and industrial buildings. When the setback is 100 feet or less.

- (1) Apartments: An illuminated, diagrammatic representation of the apartment complex shall be installed at the primary vehicular entrances to each apartment complex unless otherwise indicated by the Fire Chief. Refer to Drawing 11-E.

Each building shall be marked at a location clearly visible from the street and/or the nearest vehicular access. Markings shall include building number/letter and numbers of units located in that building.

Example:

Bldg. "B"	Building Designation
Units 1-8	Units in Building

The building number or letter and the apartment number or letter shall be 6" high with a stroke of 3/4" and shall contrast with the background. Exterior lighting shall be provided which will illuminate the building identification sufficiently to render it visible from the vehicular access.

The individual apartments shall be identified by numerals and/or letters centered in the upper half of the primary entrance door. If the numbers would be concealed by a screen door (if placed on the door), then they shall be placed on the doorframe or other location immediately outside the door and visible from all angles of approach.

Additionally, if the apartment has access via a rear patio door or gate, it shall also be marked in the same manner. The numbers or letters shall be at least 3" tall and of at least 1/2" stroke. They shall all be of contrasting color to the background.

- (2) Commercial: Individual buildings shall be addressed front and back. Minimum numeral size is 6" high with 3/4" stroke and shall contrast with the background. Exterior lighting shall be provided which will illuminate the building identification sufficiently to render it visible from the vehicular access. Rear doors servicing individual businesses shall be marked to indicate the address and unit identification, if unit identification is applicable.
- (3) Industrial: Individual buildings shall be marked at a point clearly visible from the street and/or the nearest vehicular access. Minimum size shall be 12" high with a 1 1/2" stroke and shall contrast with the background. Exterior lighting shall be provided which will illuminate the building identification sufficiently to render it visible from the vehicular access. Rear doors servicing individual businesses shall be marked to indicate the address and unit identification, if unit identification is applicable.
- (4) "Spec" Warehouses: Individual units shall have unit and the number/space listed above the main entrance. The building shall be marked at the point nearest the street. Units with frontage on both sides of a building shall have identical markings on both sides. Minimum size for individual units shall be 6" high with a stroke of 3/4" and shall contrast with the background. Exterior lighting shall be provided which will illuminate the front building identification sufficiently to render it visible from the vehicular access. Rear doors servicing individual businesses shall be marked to indicate the address and unit identification, if unit identification is applicable.

In all buildings numeral/letter height and stroke shall be doubled for each additional 100' of setback up to 300'. All accessory rooms shall be labeled to the satisfaction of the Oakdale Public Services Department.

Building identification materials, including paint colors and exterior lighting fixtures, are subject to approval by the Community Development Department. Alternatives to the methods addressed in this document should be presented to the Oakdale Public Services Department and to the Community Development Department for consideration and approval.

Maintenance of building identification is the responsibility of the Building Owner and/or Manager.

**NOTE:** The above summary is not comprehensive. Applicants are responsible for compliance with all applicable requirements.

## 11.5 STREET NAMING STANDARD

The purpose of the City of Oakdale, Street Naming Standard is to provide for the orderly assignment of Street Names, to protect the safety of the general public. The Public Works Department is the only agency with the authority to assign or modify Street Addresses within this jurisdiction. The selection of the street names will be of a technical review by the Stanislaus Regional 911, Oakdale Police, Planning Departments and County Planning.

- (1) The Developer proposed new street names for the development to Stanislaus Regional 911 (Regional Dispatch Center) via e-mail.
  - (a) The submittal must be clearly legible and include the proposed street names, street type suffixes and APNs of the property to be developed.
  - (b) A tentative, improvement, or proposed map in .pdf file format should also be submitted with the names clearly identified on the map.
- (2) The proposed Street Names should not conflict with already established street names within this County. Applicants shall utilize a County Map such as Thomas Brothers Map books for reference. Similar street names may be approved as long as the same name does not exist within the community and the address range is different. Duplicated street names within the City of Oakdale will not be accepted.
- (3) Proposed Street Names must be simple to pronounce. The main objective is to provide clear Street Names of Citizens and for Emergency Dispatch and to minimize the possibility of Emergency Personnel being unable to find a location.
- (4) Anytime that a Street makes a directional change of approximately (90° - ninety degrees), the Street Name shall change. A directional change of approximately (90° - ninety degrees) shall mean a horizontal curve where a reduction in the design speed is required (i.e. a sharp turn vs. a sweeping curve).
- (5) Use only accepted Suffixes Accepted Suffixes are attached.
- (6) Suffix – All East/West directions are Streets, Ways or Places, and North/South directions are Drives, Avenues, or Lanes. All Cul-de-Sacs shall have a suffix of Court. If the road travels in both directions, then the direction with the greatest exposure will be labeled accordingly. See Drawing 11-D-1 for additional information.

Note: After the Street Names have been approved and returned to the Developer, it will be a requirement to identify the Streets by name on the submitted improvement or final map, for final City of Oakdale review and approval.

Process:

- (A) Developer submits proposed list of Street names to Oakdale Public Services Department for review.
- (B) Stanislaus Regional 911 prepares the "Tentative Proposed Street Name Approval List" including research results & suggested responses, then forwards the list to the Oakdale Public Services Department as the City of Oakdale contact and County Planning Department. The Oakdale Public Services Department forwards the list for review to the Police and Planning Departments.

- (C) After Review and comments by the City of Oakdale and County Planning, the tentative list of names is then returned to Stanislaus Regional 911 to finalize the list.
- (D) Agreed upon changes to the tentative list are incorporated into the final list, the Stanislaus Regional 911 returns the final list to the Developer, Oakdale Public Services, Police, Oakdale Planning Department and County Planning.
- (E) The Public Services Department will plan review the improvement or final maps to ensure compliance.
- (F) After the Final Map has been recorded by Stanislaus County, the approved street names not used by the developer will be released. The Oakdale Public Services Department will notify Stanislaus Regional 911 of the unused names.

### **11.6 ILLUMINATED DIRECTORY**

This standard has been developed for the purpose of clearly identifying and marking of proper addresses pursuant to California Building and Fire Code, as adopted by Ordinance by the City of Oakdale.

- (1) In addition to individual building suite or apartment numerals or letters, condominiums, apartment complexes, townhouses, mobile home parks and multiple commercial buildings shall have installed at points of entry, an illuminated directory sign.
- (2) The directory sign shall consist of the following:
  - (A) A plot plan showing private drive.
  - (B) Access roads.
  - (C) Building locations with unit number and addresses.
  - (D) Fire hydrant locations
  - (E) Name of complex
  - (F) A reference point on the plot plan indicating the location of the directory.
  - (G) A North direction indicator.
- (3) The Developer or the Property Owner shall submit to the Oakdale Public Services Department for review and approval a detailed plan showing size, materials, method of construction, electrical components and wiring, and location of installation.
- (4) Figure 1 indicates the minimum dimensions of the directory. See Drawing 11-E.
- (5) Illumination may be by either internal or external lighting source.

Note: Existing buildings constructed prior to the effective date of this standard need not conform to the illumination requirement of this standard.

### **11.7 FIRE LANES**

This standard has been developed pursuant to California Building and Fire Code as adopted by ordinance by the City of Oakdale. It is intended that this standard be used as a guide for installation and placement of signs and

markings designated as a Fire Lane, where required by the Fire Marshal, in order to provide adequate Fire Department vehicle access.

(1) General

- (A) "No Parking Fire Lane" signs and curb markings shall conform to the requirements outlined below as required by the Fire Marshal.
- (B) Signs and curb markings shall be installed on any highway, at any curb, or in any location in a publicly or privately owned or operated off-street parking facility, required to be posted by the Fire Marshal, in order to provide the necessary unobstructed width and adequate turning radius to Fire Department apparatus.
- (C) All signs and curb markings are to be installed and maintained by the property owner.
- (D) All curbs adjoining Fire Lanes or posted areas shall be painted Red and labeled "No Parking Fire Lane". Curb markings and lettering shall conform to Figure IV, "DRAWING NO. 11-F-1"
- (E) Detailed plans of the proposed Fire Lane markings shall be provided to the Fire Marshal for review prior to installation.
- (F) Signs and curb lettering are subject to the approval of the Fire Marshal.

(2) No Parking Signs:

(A) Sign #1 Location

- (1) Signs marking Fire Lanes are to be spaced so they are within 3 feet of each end of curbed areas and spaced a minimum of fifty (50) feet apart thereafter, see Figures I and II Drawing 11-F.
- (2) In addition, 1 sign is required for each island adjacent to a Fire Lane or access road, if the road width is less than 20', see reference A, Figure II, Drawing 11-F.
- (3) Signs are to face oncoming vehicular traffic.
- (4) All curbs adjoining Fire Lanes or posted areas shall be painted Red and labeled, see Figure IV, Drawing 11-F-1. Curb markings shall be spaced every twenty-five (25) feet.

## **11.8 PLACARD AND LABELING REQUIREMENTS**

The purpose of this standard shall provide guidance to facilities and businesses which are required to post placards or labels for hazard identification as directed by the Oakdale Public Services Department, in designing the appropriate size and/or design of the placard or label. This standard has been developed pursuant to provision of the California Fire Code as adopted by the Oakdale Public Services Department.

(1) Where Required:

Placards and labels shall be clearly posted in the following locations and/or as required by the Oakdale Public Services Department.

Placards:

- (1) At all main entrances to facilities and buildings that use, store or process hazardous materials or reporting quantities.
- (2) On entry gates or fences to facilities, buildings, and exterior storage areas.
- (3) At entrances to inside storage rooms or designated storage areas.
- (4) Entrances to cylinder (pressurized or cryogenic) storage areas.
- (5) On all parked trailers and/or cargo vehicles and shipping containers (see transport containers) which are used for temporary and/or permanent storage of hazardous materials.

Labels:

- (1) On all drums and/or tanks 30-gallon capacity or larger.
- (2) On all approved storage cabinets.
- (3) On all pressurized cylinders greater than 200 cu. ft. capacity.
- (4) On all liquefied gases in excess of 150-gallon capacity.

(2) Placard and Label Specifications

- (1) All labels and placards shall utilize the National Fire Protection Association (NFPA) color coded hazard warning system.
- (2) The numerical hazard rating shall comply with NFPA hazard rating index shown in Figure 2, Drawing 11-G-1. The hazard rating may be designated reviewing the Material Safety Data Sheets or by contacting the Oakdale Public Services Department.
- (3) Placards and labels shall be constructed of weatherproof/resistant backings and materials.
- (4) Dimensions shall not be less than specified in Figure 1, Drawing 11-G.
- (5) The numerical hazard rating shall be black in color.
- (6) Diamond colors shall be blue, red, yellow, and white representing Health, Fire, Reactivity and Other, respectively as indicated in Figure 1, Drawing 11-G.

## **11.9 KEY BOX REQUIREMENTS**

This standard is promulgated pursuant to the California Fire Code as adopted by the City of Modesto Fire Department.

(1) General

A "Key Box" is required where: (1) access to buildings is difficult; (2) in buildings with fire alarm, sprinkler systems, or specialized fire protection systems; (3) all facilities that are required to submit a hazardous materials business plan; (4) where electronic and manual gates could hamper emergency access; (5) in building or facilities when required by the Fire Chief.

After investigation of the available products, it has been determined that only the product line offered by the Knox Company, of Irvine, satisfies the security needs of the Fire Department and the Community.

(2) Ordering Procedures

- (A) The Standard Knox box model is 3200. Customer shall determine whether the box is surface mount or recessed. The model 4400 may be required based on multiple suites or size of complex.
- (B) Taking into consideration the number of keys necessary to ensure adequate access and the need for floor / site plans, hazardous material business plans etc.
- (C) Complete the authorization form and submit the order with payment directly to the Knox Company, 17671 Armstrong Avenue, Irvine, CA 92614-5728, (800) 552-5660, (949) 252-8181, Fax: (949) 252-0482, Web: [www.knoxbox.com](http://www.knoxbox.com). Select "Oakdale City Fire Department" as the agency.

Installation Procedure:

(1) In general, the location must meet the following criteria:

- (A) The Key Box shall be mounted at the right side of the main entrance or gate. Where more than one (1) box is required, each box shall be located adjacent to the entrance / gate / door / elevator which it is intended to serve.

- (B) The Key Box shall be mounted not less than five (5) feet and not greater than six (6) feet above the finish floor and not more than three (3) feet from the right-hand side of the main entrance to the building facility (access location).
- (C) A Knox Decal shall be placed on the entrance door.
- (D) The box should be mounted using heavy “lag bolts” or other sturdy devices to secure the box to the wall.
- (E) Assemble all of the following for placement into the box:
  - (i) One for main entry
  - (ii) One for elevator override (where applicable)
  - (iii) One for the fire alarm or sprinkler system at the fire control room
  - (iv) One grand master key for each floor, each wing.

After installation of the Knox Lock Safe, contact the Modesto Fire Department to test and secure the access keys into the safe.

Knox Key Switches for gates shall be per Drawing 11-K.

### **11.10 AUTOMATIC EMERGENCY VEHICLE ACCESS GATES**

#### SCOPE:

Fire Apparatus Access Roads which are secured by gates shall comply with the specifications of the Modesto Fire Department. Electrically controlled gates which are not manned on a 24-hour basis shall be provided with an approved vehicle detector/receiver system in accordance with these guidelines. Gates shall be capable of being manually opened or shall be provided with battery back-up in the event of power failure which shall cause the gates to remain in the open position until power is restored. Access gate systems shall be maintained and operational at all times. Repairs shall be in accordance with original specifications.

#### PURPOSE:

To provide guidance and specifications whenever electrically operated access gates are installed across any emergency vehicle access way.

#### SPECIFICATIONS AND REQUIREMENTS:

##### (1) Installation Specifications

- (A) Gates must have a minimum clear opening width of 20’-0”  
Exception: The Fire Chief may permit reduced gate widths when unusual circumstances are encountered. Developers wishing to utilize the exception must identify reason(s) for reducing gate widths in writing to the Modesto Fire Department.
- (B) Gates must begin automatic opening sequence at a point no closer than 25’-0” as for reducing gate widths in writing to the Oakdale Public Services Department.
- (C) Electrically operated access gates must be equipped with an Automatic Vehicle Identification System, utilizing a standard roadway loop to a vehicle detector/ receiver which is to be mounted on Oakdale Public Services Department emergency response vehicles.

- (D) Underground roadway loop must extend across center of road, to be within 2'-0" of right and left sides of access lane.
- (E) Automatic Vehicle Identification Access System installation must incorporate the following:

Reno A&E – Receiver Model AVI-B-1-911  
Wiring Harness Model LMH8R  
Puck: AVI-TS-911

- (F) The system may be purchased from:  
Control Products Systems Group  
1172 National Drive. STE #70  
Sacramento CA, 95834  
PH: 916-664-5965  
Email: SACRAMENTO@CONTROLPRODUCTS.COM

(2) Plans and Specifications

Two sets of plans and specifications for fire apparatus access road gates shall be submitted for review and approval prior to construction. Included in the submittal shall be the following information:

- (A) Site plan with north arrow, roadway, and gate dimensions.
- (B) Location and length of underground roadway detector loop.
- (C) Manufacturer's specification sheets detailing the voltage, current, radio frequency, power cable and coding for the proposed system.
- (D) Detailed vicinity map.

(3) Inspection

- (A) A final inspection, conducted by the Modesto Fire Department, is required prior to placing the Automatic Vehicle Identification System into use.

The following conditions apply:

- (i) Approved Plans must be provided on site at time of inspection.
- (ii) Inspections must be scheduled a minimum of 24 hours in advance.
- (iii) Installations must conform to approved plans.

(4) Operation Testing

- (A) An operational test shall be conducted prior to placing the system into operation to establish that the final installation complies with this code and the specified design and is functioning properly.

END OF SECTION

---

## 12. STORM WATER QUALITY

---

### 12.1 GENERAL:

The City of Oakdale is required by State and Federal regulations to develop programs to control the discharge of pollutants to the municipal storm drain system or to surface water bodies of the State, including the discharge of pollutants from construction sites. As a result, all construction projects are subject to the State mandated requirements designed to improve stormwater quality under the Clean Water Act.

Generally, projects that disturb one or more acres of soil or whose projects disturb less than one acre but are part of a larger common plan of development that in total disturbs one or more acres, are required to obtain coverage under the General Permit for Discharges of Storm Water Associated with Construction Activity, Construction General Permit Order 2009-0009-DWQ. Construction activity subject to this permit includes clearing, grading and disturbances to the ground such as stockpiling, or excavation, but does not include regular maintenance activities performed to restore the original line, grade, or capacity of a utility/facility.

To be covered by the NPDES permit, the Developer must submit a Notice of Intent (NOI), a Storm Water Pollution Prevention Plan (SWPPP), and the appropriate fee to the State Water Resources Control Board. All developers shall submit a Notice of Intent (NOI) to the State Water Resources Control Board for all projects disturbing 1 acre or more. A copy of the NOI and the WDID number issued by the state shall be submitted to the City Engineer prior to the commencement of any project's plan review. A copy of the SWPPP that has been reviewed and approved by the State shall be provided to the City.

The Developer is responsible for compliance with all Federal, State, and local permits, rules, regulations, ordinances, statutes, and directions that apply to erosion, sediment, and water pollution control. Failure to obtain the required permit coverage or to comply with the requirements of the required permits could result in significant daily fines or penalties imposed by the State.

The minimum standards provided in the SWPPP do not relieve the Developer from liability of storm water pollution discharged caused by construction activities. The Developer shall implement best management practices regardless of project size in accordance to all relevant rules, regulations, and laws of the governing agency.

### 12.2 GRADING ACTIVITY DISTURBING ONE ACRE OR MORE OF LAND

A National Pollution Detection and Elimination System (NPDES) permit will be required for all construction projects involving the grading, filling, excavation, storage, or the clearing or grubbing of one (1) acre or more of land. If a NPDES permit is required, then both an Erosion and Sediment Control Plan (ESCP) and a Storm Water Pollution Prevention Plan (SWPPP) must be provided as part of the initial plan review submittal requirements.

In general, the project SWPPP shall meet these minimum requirements:

- a. A SWPPP must identify appropriate stormwater pollution prevention measures or Best Management Practices (BMPs) to reduce pollutants in stormwater discharges from the construction site to the maximum extent practicable (MEP).
- b. A SWPPP must be prepared by a licensed Qualified Stormwater Developer (QSD) licensed by the State.
- c. A copy of the SWPPP must be kept readily available on the project side throughout the construction period and must be made available to City and State inspectors.
- d. The SWPPP should contain a site map(s) which shows the construction site perimeter, existing and proposed buildings, lots, roadways, storm water collection and discharge points, general topography both before and after construction, and drainage patterns across the project.

- e. The SWPPP must list Best Management Practices (BMPs) the discharger will use to protect storm water runoff and the placement of those BMPs. Additionally, the SWPPP must contain a visual monitoring program; a chemical monitoring program for “non-visible” pollutants to be implemented if there is a failures of BMPs; and a sediment monitoring plan if the site discharges directly to a water body listed on the 303(d) list for sediment. Section A of the Construction General Permit describes the elements that must be contained in a SWPPP.

The applicant shall submit the WDID (Waste Discharge Identification Number) issued by the State of California prior to the issuance of the grading permit. A copy of the Notice of Intent (NOI) shall also be provided prior to plan approval and/or issuance of a grading permit.

The NOI can be filed using the State’s online Storm Water Multiple Application and Report Tracking System (SMARTS). SMARTS has been developed to provide an online tool to assist dischargers in submitting their Notice of Intents (NOIs), Notice of Termination (NOTs), and Annual Reports, as well as, viewing/printing receipt letters, monitoring the status of submitted documents, and viewing application/renewal fee statements.

Additional assistance with the NPDES permit may be obtained from the California State Water Resources Control Board (SWRCB) by calling 866-563-3107 or visiting the following website: [www.swrcb.ca.gov/stormwtr](http://www.swrcb.ca.gov/stormwtr)

### **12.3 GRADING ACTIVITY DISTURBING LESS THAN ONE ACRE OF LAND**

All construction projects will be required to develop and implement and Erosion and Sediment Control Plan (ESCP), regardless of the project size. At a minimum, the erosion & sediment control plan must contain the following items:

- a. Erosion control measures.  
Refer to CASQA Sections EC-a to EC-13 and choose appropriate measures for project site.
- b. Sediment control measures.  
Refer to CASQA Sections SE-1 to SE-10 and choose appropriate measures for project site.
- c. Drain inlet protection.  
Refer to CASQA Section SE-10. Mandatory for all projects.
- d. Stabilized entrance and egress from construction site.  
Refer to CASQA sections TC-1, TC-2, & TC-3.
- e. Concrete wash-out area.  
Refer to CASQA Section WM-8.
- f. Responsible Party.  
Name of party responsible for implementation of and adherence to the erosion & sediment control plan.
- g. Size of project in acres.
- h. Any other BMP’s necessary to control the discharge of pollutants from the construction site.

### **12.4 STORMWATER BEST MANAGEMENT PRACTICES (BMPs)**

The California Stormwater Quality Association (CASQA) Stormwater Best Management Practice Handbook for Construction contains guidelines for the preparation of SWPPP. The CASQA Handbook may be viewed online at [www.cabmphandbooks.com](http://www.cabmphandbooks.com)

The City of Oakdale has adopted the Best Management Practices (BMPs) listed in the current edition of the California Stormwater Quality Association (CASQA) "Stormwater Best Management Practice Handbook for Construction". Developers, Contractors and Engineers are encouraged to use this publication in developing appropriate pollution control measures for individual construction projects.

The Developer shall implement and maintain, as a minimum, the following stormwater quality BMP practices:

- a. The Developer shall perform routine inspection and maintenance of BMP's. Inspections shall be done prior to, during, and after each qualifying rain event. The Developer is solely responsible for preparing and maintaining inspection and monitoring records.
- b. The Developer shall immediately correct or replace any ineffective BMP. If the measures taken by the Developer are inadequate to effectively control water pollution, the Developer may need to revise the operations and water pollution control program.
- c. Ineffective BMP may restrict the construction work from being performed until the water pollution control measures are made adequate. Continued noncompliance may result in a Notice of Violation (NOV) and/or suspension of the work indefinitely. The City Engineer reserves the right to take corrective action as needed to correct any noncompliance issues at the Developer's sole expense.
- d. Contractors (or other responsible party) shall conduct regular inspections and maintenance of stormwater BMPs on the construction site. The party performing the inspection must be done by a licensed Qualified Stormwater Practitioner (QSP). Active construction sites may be visited at any time by City inspection staff.
- e. It shall be the responsibility of the owner and the permittee to ensure that erosion does not occur from any activity during or after project construction. Additional measures, beyond those specified, may be required as deemed necessary to control accelerated erosion.

## **12.5 POST-CONSTRUCTION MEASURES**

The City of Oakdale is required to regulate development within the city to comply with Section E.12 (Post-Construction Storm Water Management) of General Permit 2013-0001-DWQ. In 2015, the City of Oakdale adopted a "Post-Construction Standards Plan" to guide project proponents through the various site design requirements of the Phase II Municipal Separate Storm Water Sewer System (MS4) Permit. This document can be downloaded from the city's website.

There are basically three categories of projects that will be reviewed by the city for compliance with the permit:

- a. Site Design Measures (generally projects that create and/or replace between 2,500 s.f. and 5,000 s.f. of impervious surface). Projects in this category are required to implement one or more site design measures from Section E.12.b.ii of the General Permit.
- b. Regulated Projects (generally projects that replace or create more than 5,000 s.f. of impervious surface). Projects in this category must comply with more stringent requirements, which may include some or all of the following: Measures for Site Design, Source Control, and Low Impact Development (LID). LID may include: runoff reduction, storm water treatment and baseline hydromodification management.
- c. Road & LUP's (Linear Underground/overhead projects). Some Road Projects and LUP's (Linear Underground/overhead projects) will be required to implement LID measures.

It is the developer's responsibility to become familiar with the requirements of the General Permit and the City's Post-Construction Standards Plan, and incorporate design features into their projects that will meet the applicable implementation requirements of the permit. The city will review submittals for compliance, as well as perform required reporting.

END OF SECTION



# PROJECT BILLING INFORMATION FORM

## PROJECT / OWNER INFORMATION

**PROJECT:**

PROJECT NAME \_\_\_\_\_ DATE \_\_\_\_\_

PROJECT LOCATION \_\_\_\_\_

**OWNER:**

COMPANY \_\_\_\_\_ NAME \_\_\_\_\_

ADDRESS \_\_\_\_\_ EMAIL \_\_\_\_\_

CITY, STATE, ZIP \_\_\_\_\_ PHONE \_\_\_\_\_

**APPLICANT:**

COMPANY \_\_\_\_\_ NAME \_\_\_\_\_

ADDRESS \_\_\_\_\_ EMAIL \_\_\_\_\_

CITY, STATE, ZIP \_\_\_\_\_ PHONE \_\_\_\_\_

## OWNER AUTHORIZATION

*I agree to take full financial responsibility for all costs accrued by the City for the overall daily management of my project, which ensures that all codes, laws, standards and permits are enforced. This may include and is not limited to: plan/map reviews and revisions, encroachment permits, inspections, and administrative support. The financial responsibility accepted herein shall continue in full force and effect until the project is completed and all amounts due to the City are paid in full, or until such time that I instruct the City in writing to cease all work on the project, at which time all amounts due to the City shall become due and payable in accordance with this agreement.*

*I am aware that I may receive an invoice for my account but that no invoices will be sent for a typical fixed fee project. I shall pay finance charges for the unpaid balance at a percentage rate established by City policy. All payments are due upon receipt. I will contact the City within 45 days if I feel that I have been invoiced in error. All charges are my financial responsibility if I do not contact the City within 45 days. The City reserves the right to stop their work and/or my work on this project for unpaid balances and all charges must be paid prior to project approval. If I sell or option this property, I will disclose the terms of this statement and provide the City with new billing information. If I fail to do this, I will continue to be financially responsible for all future costs related to this project, and shall be responsible for any unpaid balance accrued during ownership of the property.*

**If signed by an authorized agent, you will need to attach the Letter of Authorizaion Form.**

OWNER'S SIGNATURE \_\_\_\_\_ PRINT NAME \_\_\_\_\_ DATE \_\_\_\_\_

APPLICANT'S OR AUTHORIZED AGENT'S SIGNATURE \_\_\_\_\_ PRINT NAME \_\_\_\_\_ DATE \_\_\_\_\_

All correspondence for this project should be emailed/mailed to:  OWNER  APPLICANT

## FOR CITY USE ONLY

DATE _____	AMOUNT RECEIVED _____	RECEIVED BY _____	CD NUMBER _____
------------	-----------------------	-------------------	-----------------

## PROJECT / APPLICANT INFORMATION

### PROJECT:

PROJECT NAME \_\_\_\_\_ DATE \_\_\_\_\_

SITE PLAN APP. NO. \_\_\_\_\_ BLDG. PERM. APP. NO. \_\_\_\_\_ SIZE (ACRES) \_\_\_\_\_ W.D.I.D. NO. \_\_\_\_\_

### APPLICANT:

COMPANY \_\_\_\_\_ NAME \_\_\_\_\_

ADDRESS \_\_\_\_\_ EMAIL \_\_\_\_\_

CITY, STATE, ZIP \_\_\_\_\_ PHONE \_\_\_\_\_

## INSTRUCTIONS & CHECKLIST

*This application is for projects that include the installation of on-site (private) improvements (commercial & industrial sites, churches, multi-family complexes, etc.). While these projects typically include a Building Permit Application, this separate Application to the Engineering Division is required for the Civil and Landscape Plans (and supporting documents). This Application should be submitted at the same time as the Building Permit Application, but under separate cover to the Engineering Division at the Public Services Department (455 S. Fifth Street) in PDF format. The file can be emailed to [MRenfrow@ci.oakdale.ca.us](mailto:MRenfrow@ci.oakdale.ca.us) or submitted on a disc or thumb drive.*

### Submittal Checklist:

- Civil Improvement Plans
- Landscape & Irrigation Plans
- Storm Drain Storage Calculations
- Geotechnical Report
- Wall Plans (if applicable)
- W.D.I.D. Number (cover sheet of plans)
- SWPPP
- Project Billing Information Sheet
- Plan Check Deposit - \$1,000

### With Final Submittal:

- Engineer's Estimate
- Civil Cover Sheet (Mylar)

### Plan Submittal Information:

*Improvement Plans, Calculations, Studies and Reports shall be stamped and signed by a registered civil engineer (or geotechnical engineer, landscape architect etc.). Plans shall be on 24"x36" sheets only, and shall conform to the current version of the City of Oakdale Improvement Standards.*

### Oakdale Improvement Standards:

*The current edition of the Oakdale Improvement Standards can be obtained at [www.ci.oakdale.ca.us](http://www.ci.oakdale.ca.us).*

### Plan Check Process:

*Upon receipt of the items shown in the checklist (including deposit payment), the plans will be routed to appropriate departments for plan check. Generally, plan check comments will be provided in approximately 2 weeks in PDF format to applicant (via email if file size is not prohibitive).*

### Deposit & Payments:

*The city utilizes a "Deposit-based" fee system for this application. If the initial deposit is not adequate, the city will request additional funds from developer. Upon approval of plans any excess funds will be returned to the owner/applicant or applied to the cost of inspections. See "Project Billing Information Form" for more information.*

### Approval:

*Upon approval of the plans, the City Engineer will email the applicant an approval letter with instructions for obtaining required permits and procedures that must be followed prior to constructing the site improvements. Upon receipt of the materials requested, the City Engineer will sign the plans and the Engineering Division will issue the required permits.*

**PROJECT / APPLICANT INFORMATION**

**PROJECT:**

SUBDIVISION NAME \_\_\_\_\_ DATE \_\_\_\_\_

TENT. MAP APP. NO. \_\_\_\_\_ W.D.I.D. NO. \_\_\_\_\_ NO. OF LOTS \_\_\_\_\_ SPECIFIC PLAN (If Applicable) \_\_\_\_\_

**APPLICANT:**

NAME \_\_\_\_\_ EMAIL \_\_\_\_\_

COMPANY \_\_\_\_\_ PHONE \_\_\_\_\_

ADDRESS \_\_\_\_\_

**INSTRUCTIONS & CHECKLIST**

*This application is for processing subdivision improvement plans and final maps (including parcel maps that require public improvements). Application materials should be submitted to the Public Services Department (455 S. Fifth Street) in PDF format. The file can be emailed to [MRenfrow@ci.oakdale.ca.us](mailto:MRenfrow@ci.oakdale.ca.us) or submitted on a disc or thumb drive.*

**Improvement Plans Submittal:**

- Civil Improvement Plans
- Calculations (Sewer, Storm, Water)
- Supporting Studies (Geotech, Traffic, etc.)
- Project Billing Information Form
- Plan Check Deposit - \$50/lot (\$2,000 minimum)

*May be deferred until 2nd Submittal:*

- Landscape & Irrigation Plans
- Joint Trench Plans
- Traffic Signal Plans
- Wall Plans
- W.D.I.D. Number (on cover sheet of plans)
- SWPPP

**Final Map Submittal:**

- Final Map
- Closure Calculations
- Title Report (within 6 months)
- Underlying Documents
- Grant Deed
- Reference Maps

**Additional Items for Approval of Plans & Recordation of Final Map:**

- |  |   |
|--|---|
| <ul style="list-style-type: none"> <li><input type="checkbox"/> Mylar Cover Sheet</li> <li><input type="checkbox"/> Engineer's Estimate (for Bonds)</li> <li><input type="checkbox"/> Air Impact Assessment Approval (SJVAPCD)</li> <li><input type="checkbox"/> Grading Permit Application &amp; Fee</li> <li><input type="checkbox"/> Encroachment Permit Application</li> <li><input type="checkbox"/> Fire Hydrant Use Permit</li> </ul> | <ul style="list-style-type: none"> <li><input type="checkbox"/> Mylar Sheets</li> <li><input type="checkbox"/> Bonds (Performance, Labor &amp; Materials)</li> <li><input type="checkbox"/> Tax Letter</li> <li><input type="checkbox"/> Subdivision Guarantee</li> </ul> |
|--|---|

**Additional Items for Acceptance of Improvements & Release of Bonds:**

- |  |  |
|--|--|
| <ul style="list-style-type: none"> <li><input type="checkbox"/> Record Drawings</li> </ul> | <ul style="list-style-type: none"> <li><input type="checkbox"/> Warranty Bond</li> </ul> |
|--|--|

**Oakdale Improvement Standards:**

*A current version of the Oakdale Improvement Standards can be downloaded at [www.ci.oakdale.ca.us](http://www.ci.oakdale.ca.us)*

### ADDITIONAL INSTRUCTIONS

#### **Plan Submittal Information:**

*Improvement Plans, Calculations, Studies and Reports shall be stamped and signed by a registered civil engineer (or geotechnical engineer, landscape architect etc.). Proposed improvements must be consistent with the approved Tentative Map Conditions of Approval for the project, and the City of Oakdale Improvement Standards. Other submittal materials, in addition to those in the checklist above may be required to satisfy the Conditions of Approval, environmental mitigation measures, or other unique site conditions. Plans shall be on 24"x36" sheets only.*

#### **Plan Check Process:**

*Upon receipt of the items shown in the checklist (including deposit payment), the plans will be routed to appropriate departments for plan check. Generally, plan check comments will be provided in approximately 2 weeks in PDF format to applicant (via email if file size is not prohibitive).*

#### **Deposit & Payments:**

*The city utilizes a "Deposit-based" fee system for this application. If the initial deposit is not adequate, the city will request additional funds from developer. Upon approval of plans any excess funds will be returned to the owner/applicant or applied to the cost of inspections. See "Project Billing Information Form" for more information.*

#### **Approval:**

*Upon approval of the plans, the City Engineer will email the applicant an approval letter with instructions for obtaining required permits and procedures that must be followed prior to constructing the site improvements. Upon receipt of the materials requested, the City Engineer will sign the plans and the Engineering Division will issue the required permits.*



# PARCEL MODIFICATION PLAN REVIEW

## PROJECT / APPLICANT INFORMATION

**PROJECT:**

PROJECT NAME \_\_\_\_\_ DATE \_\_\_\_\_

SITE PLAN APP. NO. \_\_\_\_\_ BUILDING PERMIT NO. \_\_\_\_\_ SIZE (ACRES) \_\_\_\_\_ W.D.I.D. NO. \_\_\_\_\_

**APPLICANT:**

COMPANY \_\_\_\_\_ NAME \_\_\_\_\_

ADDRESS \_\_\_\_\_ EMAIL \_\_\_\_\_

CITY, STATE, ZIP \_\_\_\_\_ PHONE \_\_\_\_\_

## INSTRUCTIONS & CHECKLIST

This application is for processing Parcel Maps (that don't require the installation of public improvements), Lot Line Adjustments and Lot Mergers. Application materials should be submitted to the Public Services Department (455 S. Fifth Street) in PDF format. The file can be emailed to [MRenfrow@ci.oakdale.ca.us](mailto:MRenfrow@ci.oakdale.ca.us) or submitted on a disc or thumb drive.

**Parcel Map Submittal:**

- Final Map
- Closure Calculations
- Title Report (within 6 months)
- Underlying Documents
- Grant Deed
- Reference Maps
- Project Billing Information Form
- Fee Deposit (\$1,000)

**Lot Line Adjustment Submittal:**

- Legal Descriptions (before & after)
- Plats (before & after)
- Project Billing Information Form
- Fee Deposit (\$1,000)

**Lot Merger Submittal:**

- Legal Descriptions (before & after)
- Plats (before & after)
- Project Billing Information Form
- Fee Deposit (\$1,000)

**Plan Submittal Information:**

Final Map & Closure Calculations shall be prepared by a Licensed Land Surveyor. Map sheets shall be 18"x26".

**Plan Check Process:**

Upon receipt of the items shown in the checklist (including deposit payment), the submittal materials will be routed for plan check. Generally, plan check comments will be provided in approximately 2 weeks in PDF format to applicant (via email if file size is not prohibitive).

**Deposit & Payments:**

The city utilizes a "Deposit-based" fee system for this application. If the initial deposit is not adequate, the city will request additional funds from applicant. Upon approval of application any excess funds will be returned to the owner/applicant. See "Project Billing Information Form" for more information.

**Approval:**

These applications require approval of the Director of Public Services (no public hearing required). Upon approval of the application, the City Engineer will email the applicant an approval letter with instructions for recording the Parcel Map, LLA or Lot Merger.



# STANDARD ENCROACHMENT PERMIT

## CONTRACTOR INFORMATION

CONTRACTOR: \_\_\_\_\_ TELEPHONE: \_\_\_\_\_  
 ADDRESS: \_\_\_\_\_ CITY/STATE/ZIP: \_\_\_\_\_  
 CONTRACTOR LICENSE NO.: \_\_\_\_\_ CITY BUSINESS LICENSE NO.: \_\_\_\_\_  
 ADDRESS: \_\_\_\_\_ CITY/STATE/ZIP: \_\_\_\_\_

Forward permit copy by:  Mail,  Fax, or  E-Mail:

## ENCROACHMENT INFORMATION

**Describe work to be performed:** \_\_\_\_\_  
**Location / Address:** \_\_\_\_\_

Submit **completed** application, along with required fees, bonds, evidence of insurance and 2 copies of scaled drawings clearly showing the full scope of work.

**Please allow a minimum of 48 hours for the review of this permit.** The Undersigned hereby agrees to comply with specifications and ordinances set forth by this permit.

\*All Work Within the City Right of Way and All Connection to City Utility Services must be Applied for and Conducted by a Contractor Licensed by the State of California.

**ENCROACHMENT PERMIT TYPE:** check applicable type(s)

**Utility Street/Trench Cut:** .....  \$80 (4'x4') Bell Hole  \$115 Trench 0-100 linear ft...  \$20/each add'l 100 linear ft  
**Sidewalk:** .....  \$80, 0-100 linear ft .  \$20/each add'l 100 linear ft  
**Curb & Gutter:** .....  \$80, 0-100 linear ft .  \$20/each add'l 100 linear ft  
**Driveway Apron:** .....  \$80  
**Temporary Encroachment Permit,**  \$45  
**Permanent Encroachment Permit,**  \$150  
**Exempt Permit** ..... Reason: \_\_\_\_\_

<b>TOTAL DUE: \$</b> _____ <b>PAID:</b> <input type="checkbox"/> CASH <input type="checkbox"/> CREDIT CARD <input type="checkbox"/> CHECK # _____ Make checks out to "City of Oakdale". non-refundable fee.
---

**EXPIRATION:** If the work is not started within 45 days of the permit/approval date, this permit shall be null and void.  
**INSPECTIONS:** To schedule inspections, call Public Works Monday – Friday at (209) 845-3600 at a minimum of 24-hours in advance. Refer to next page for required inspections.

Applicant's Signature: \_\_\_\_\_ Date: \_\_\_\_\_  
 Print Name: \_\_\_\_\_

## FOR CITY USE ONLY

Public Works Approval of Permit: \_\_\_\_\_ Date: \_\_\_\_\_  
 Conditions: \_\_\_\_\_  
 \_\_\_\_\_  
 \_\_\_\_\_

Permit No. _____ Date Issued _____	<b>PUBLIC WORKS STAMP</b> (Permit invalid if not stamped)
---------------------------------------	---





# GRADING PERMIT

DATE: \_\_\_\_\_

APPLICANT'S NAME: \_\_\_\_\_ PHONE NO.: \_\_\_\_\_

APPLICANT'S ADDRESS: \_\_\_\_\_ CITY/ST/ZIP: \_\_\_\_\_

PROPERTY OWNER'S NAME: \_\_\_\_\_ PHONE NO.: \_\_\_\_\_

PROPERTY OWNER' ADDRESS: \_\_\_\_\_ CITY/ST/ZIP: \_\_\_\_\_

CONTRACTOR'S NAME: \_\_\_\_\_ PHONE NO.: \_\_\_\_\_

CONTRACTOR'S ADDRESS: \_\_\_\_\_ CONTRACTOR'S LICENSE NO.: \_\_\_\_\_  
CITY BUSINESS LICENSE NO.: \_\_\_\_\_

PROJECT ADDRESS: \_\_\_\_\_

PROJECT RELETED TO CURRENT BUILDING PERMIT:  YES  NO IF YES, BUILDING PERMIT NO.: \_\_\_\_\_

PLANNING APPLICATION NO.: \_\_\_\_\_ WDID NUMBER: \_\_\_\_\_

CEQA REVIEW REQUIRED:  YES  NO IF NO, CATEGORICAL OR STATUTORY EXEMPTION: \_\_\_\_\_

START DATE: \_\_\_\_\_ COMPLETION DATE: \_\_\_\_\_ EROSION CONTROL DATE: \_\_\_\_\_

ESTIMATED COST: \_\_\_\_\_

CUBIC YARDS OF CUT: \_\_\_\_\_ FILL: \_\_\_\_\_ IMPORT: \_\_\_\_\_ EXPORT: \_\_\_\_\_

SOURCE OF FILL:  DISPOSAL SITE:

DESCRIPTION OF WORK:

SCHEDULE OF WORK:

I hereby certify that all information provided in this application is true and complete and I agree to comply with the conditions listed.

Applicant's Signature

Date

Issuance of this Grading Permit is permitted only after the applicant has successfully processed plans through the Engineering Division under a "Subdivision Improvement Plan Review" or "Site Improvement Plan Review" process. Applicant shall pay a **deposit-based fee of 2% of the approved Engineer's Estimate (Minimum \$2,000)** to cover inspection costs. If additional funds are necessary, the City will notify the applicant. Any unused balance will be returned. All conditions in the executed "Project Billing Information Form" on file for this project will apply.

### FOR CITY USE ONLY

PUBLIC WORKS APPROVAL OF PERMIT: \_\_\_\_\_ DATE: \_\_\_\_\_

CONDITIONS: \_\_\_\_\_

Issuer (Print Name) \_\_\_\_\_  
Permit No. \_\_\_\_\_  
Date Issued \_\_\_\_\_

PUBLIC WORKS STAMP (Permit invalid if not stamped)

## GENERAL GRADING PROVISIONS

1. This permit is void if work is not begun within 60 days of issuance and not completed within one year.
2. At least 48 hours notice is required to the City of Oakdale Engineering Division. Call (209) 845-3625.
3. Call Underground Service Alert (USA) at least 48 hours prior to the start of any construction.
4. All grading and noise therefore including, but not limited to, warming of equipment motors in residential zones or within one thousand (1000) feet of any residential occupancy, hotel, motel or hospital shall limited between the hours of 7:00 a.m. to 3:30 p.m., Monday through Friday. The owner or developer must submit a written request for approval by the City Engineer at least two (2) working days in advance to work during any other hours, weekend, or holidays.
5. The permittee and/or the permittee engineer's, contractors or agents shall be responsible for the satisfactory and safe conduct of all work.
6. The permit applicant and grading contractor shall be responsible for the protection of adjacent properties during grading operation. Prior to commencing any grading of the site, the exterior boundaries shall be marked as required by the City Engineer. Boundary markers shall be maintained throughout the grading operation. Temporary barriers and /or protective fencing shall be used when necessary to protect adjacent properties.
7. The permittee and the permittee's contractor shall indemnify and save harmless the City and all officers and employees thereof connected with the work, from all claims, suites or actions of every name, kind and description, brought for , or on account of, injuries to or death of any person or damaged to property resulting from the issuance of the grading permit, construction of the work or by or in consequence of any negligence in guarding the work, use of improper materials in construction of the work, or by or on account of any act or omission by the permittee or permittee's agents.
8. Contractor shall submit a Certificate of liability Insurance to the City prior to any construction activities. Insurance shall name City of Oakdale as Additional Insured, and the Additional Insured Endorsement must be attached to deem insurance requirements complete.
9. All exposed or finished banks or slopes of any fill or exaction shall be protected from erosion by approved planting, irrigation, hydroseeding, cribbing, walls or terracing or a combination thereof. All graded surfaces exceeding five thousand (5,000) square feet in area shall be planted and irrigated, paved or built upon and shall be provided with berms and approved drainage facilities adequate to prevent erosion and to conduct the accumulation or runoff of surface waters to an approved place of discharge.
10. For commencement of the activity during the wet season, the applicant shall demonstrate to the satisfaction of the City Engineer, that land disturbances is relatively minor and that erosions and sedimentation can be controlled.
11. Erosion and sediment control measures shall be implemented as specified by the approved interim and final sediment and erosion control plans. Erosion and sediment control measures shall be consistent with the Manual of Sediment and Erosion Control Practices and Best Management Practices.
12. Upon the final completion of the work, the following reports and drawings and supplements thereto shall be submitted to the City Engineer.
  - A. A soils and geologic grading report prepared by the Soils Engineer and/or engineering geologist including location and elevations of field density test, summaries of field and laboratory tests and other substantiating data and comments on any changes made during grading and their effect on the recommendations made in the Soil Engineering Investigation Report. The report shall include a final description of the geology of the site, including any new information disclosed during the grading and the effect of same on recommendations incorporated in the approved grading plan. A certification shall be provided as to the adequacy of the site for the intended use as affected by soil and geologic factors.
  - B. An as-graded grading plan prepared by the Civil Engineer, including original ground surface elevations, as graded ground surface elevations, lot drainage patterns and locations and elevation of all surface and subsurface drainage facilities.
  - C. An as-built erosion and sediment control plan prepared by the Civil Engineer.

**The following shall be included on the General Notes sheet of the project civil improvement plans:**

**CITY OF OAKDALE GENERAL NOTES:**

1. BENCHMARK – CITY OF OAKDALE BENCHMARK # \_\_\_\_ (DESCRIPTION); NAV88 ELEV = \_\_\_\_'
2. GRADING PERMIT – NO GRADING ACTIVITIES SHALL OCCUR ON-SITE UNTIL A GRADING PERMIT HAS BEEN ISSUED BY THE CITY OF OAKDALE, AND APPLICABLE FEES HAVE BEEN PAID.
3. ENCROACHMENT PERMIT – NO WORK SHALL OCCUR IN EXISTING CITY RIGHT-OF-WAY UNTIL AN ENCROACHMENT PERMIT HAS BEEN ISSUED BY THE CITY OF OAKDALE, AND ALL APPLICABLE FEES HAVE BEEN PAID.
4. HYDRANT PERMIT – HYDRANTS MAY NOT BE USED FOR CONSTRUCTION WATER WITHOUT AN APPROVED HYDRANT PERMIT AND PAYMENT OF APPLICABLE FEES.
5. INSPECTIONS – ALL WORK SHOWN IN THESE DRAWINGS ARE SUBJECT TO INSPECTION BY THE CITY OF OAKDALE. CONTRACTOR SHALL NOTIFY PUBLIC SERVICES DEPARTMENT (209) 845-3600 AT LEAST 48 HOURS BEFORE THE START OF ANY WORK.
6. CITY STANDARDS – ALL WORK SHALL COMPLY WITH THE CURRENT EDITION OF THE CITY OF OAKDALE IMPROVEMENT STANDARDS.
7. AIR QUALITY – ALL SITE GRADING & CONSTRUCTION SHALL COMPLY WITH SAN JOAQUIN VALLEY AIR POLLUTION CONTROL DISTRICT'S REGULATION 8 FOR FUGITIVE DUST CONTROL AND PROJECT INTERNAL SOURCE REVIEW (ISR). CONTRACTOR SHALL MAINTAIN DUST CONTROL AT THE CONTRACTOR'S EXPENSE AT ALL TIMES, INCLUDING WEEKENDS, DURING THE COURSE OF CONSTRUCTION.
8. STORM WATER DISCHARGE – THIS PROJECT IS SUBJECT COVERAGE UNDER THE PHASE II GENERAL NPDES PERMIT FOR MUNICIPAL SEPARATE STORM WATER SEWER SYSTEMS (MS4). POST-CONSTRUCTION MEASURES FOR THIS PROJECT MUST COMPLY WITH THE CITY OF OAKDALE 2015 POST-CONSTRUCTION STANDARDS PLAN AND SECTION E.12 OF ORDER NO. 2014-001-DWQ, ISSUED BY THE CALIFORNIA STATE WATER RESOURCE CONTROL BOARD.
  - a. WDID NO: 0000000000
  - b. PROJECT QSP: NAME, PHONE NUMBER
9. CONDITIONS OF APPROVAL – DEVELOPER SHALL COMPLY WITH ALL CONDITIONS OF APPROVAL FOR THIS PROJECT (TSM #). ATTENTION IS CALLED TO THE FOLLOWING SELECTED CONDITIONS:

COA #00 – Condition
10. MITIGATION MEASURES – DEVELOPER SHALL COMPLY WITH ALL MITIGATION MEASURES CALLED FOR IN THE CEQA DOCUMENT FOR THIS PROJECT. ATTENTION IS CALLED TO THE FOLLOWING SELECTED MITIGATION MEASURES:

MM #000 – Mitigation . . .
11. FINAL PAVING OVERLAY – PRIOR TO ISSUANCE OF THE FINAL 10% OF BUILDING PERMITS WITHIN THIS SUBDIVISION, CONTRACTOR SHALL OVERLAY THE STREETS WITH A SLURRY SEAL, AND RE-STRIPE THE ROADWAY.

THE FOLLOWING NOTES SHALL BE INSERTED IN THE GENERAL NOTES PORTION OF THE IMPROVEMENT PLANS:

**CITY OF OAKDALE GENERAL NOTES:**

1. BENCHMARK - CITY OF OAKDALE BENCHMARK #\_\_\_ (DESCRIPTION); NAV88 ELEV = \_\_\_'
2. GRADING PERMIT - No grading activities shall occur on-site until a Grading Permit has been issued by the City of Oakdale, AND APPLICABLE FEES HAVE BEEN PAID.
3. ENCROACHMENT PERMIT - NO WORK SHALL OCCUR IN EXISTING CITY RIGHT-OF-WAY UNTIL AN ENCROACHMENT PERMIT HAS BEEN ISSUED BY THE CITY OF OAKDALE, AND ALL APPLICABLE FEES HAVE BEEN PAID.
4. HYDRANT PERMIT - HYDRANTS MAY NOT BE USED FOR CONSTRUCTION WATER WITHOUT AN APPROVED HYDRANT PERMIT AND PAYMENT OF APPLICABLE FEES.
5. INSPECTIONS - ALL WORK SHOWN IN THESE DRAWINGS ARE SUBJECT TO INSPECTION BY THE CTIY OF OAKDALE. CONTRACTOR SHALL NOTIFY PUBLIC SERVICES DEPARTMENT (209) 845-3600 AT LEAST 48 HOURS BEFORE THE START OF ANY WORK.
6. CITY STANDARDS - ALL WORK SHALL COMPLY WITH THE CURRENT EDITION OF THE CITY OF OAKDALE IMPROVEMENT STANDARDS.
7. AIR QUALITY - ALL SITE GRADING & CONSTRUCTION SHALL COMPLY WITH SAN JOAQUIN VALLEY AIR POLLUTION CONTROL DISTRICT'S REGULATION 8 FOR FUGITIVE DUST CONTROL AND PROJECT INTERNAL SOURCE REVIEW (ISR). CONTRACTOR SHALL MAINTAIN DUST CONTROL AT THE CONTRACTOR'S EXPENSE AT ALL TIMES, INCLUDING WEEKENDS, DURING THE COURSE OF CONSTRUCTION.
8. STORM WATER DISCHARGE - THIS PROJECT IS SUBJECT COVERAGE UNDER THE PHASE II GENERAL NPDES PERMIT FOR MUNICIPAL SEPARATE STORM WATER SEWER SYSTEMS (MS4). POST-CONSTRUCTION MEASURES FOR THIS PROJECT MUST COMPLY WITH THE CITY OF OAKDALE 2015 POST-CONSTRUCTION STANDARDS PLAN AND SECTION E.12 OF ORDER NO. 2014-001-DWQ, ISSUED BY THE CALIFORNIA STATE WATER RESOURCE CONTROL BOARD.

WDID NO: 0000000000

PROJECT QSP: NAME, PHONE NUMBER

9. CONDITIONS OF APPROVAL - DEVELOPER SHALL COMPLY WITH ALL CONDITIONS OF APPROVAL FOR THIS PROJECT (TSM #). ATTENTION IS CALLED TO THE FOLLOWING SELECTED CONDITIONS:

COA #00 - Condition

10. MITIGATION MEASURES - DEVELOPER SHALL COMPLY WITH ALL MITIGATION MEASURES CALLED FOR IN THE CEQA DOCUMENT FOR THIS PROJECT. ATTENTION IS CALLED TO THE FOLLOWING SELECTED MITIGATION MEASURES:

MM #000 - Mitigation . . .

11. FINAL PAVING OVERLAY - AFTER THE \_\_\_TH BUILDING PERMIT HAS BEEN ISSUED AND PRIOR TO ACCEPTANCE OF THE PUBLIC IMPROVEMENTS FOR THIS SUBDIVISION ALL PUBLIC ROADS WILL BE RESURFACED WITH A TYPE II SLURRY SEAL AND RE-STRIPED.

APPROVED BY CITY COUNCIL: RESOLUTION: 2025-094	<b>GENERAL NOTES FOR SUBDIVISIONS</b>	DATE: 09-15-25
		DRAWING NO.
ROB MARLER, P.E. - CITY ENGINEER	CITY OF OAKDALE DEPARTMENT OF PUBLIC SERVICES	<b>1-A</b>

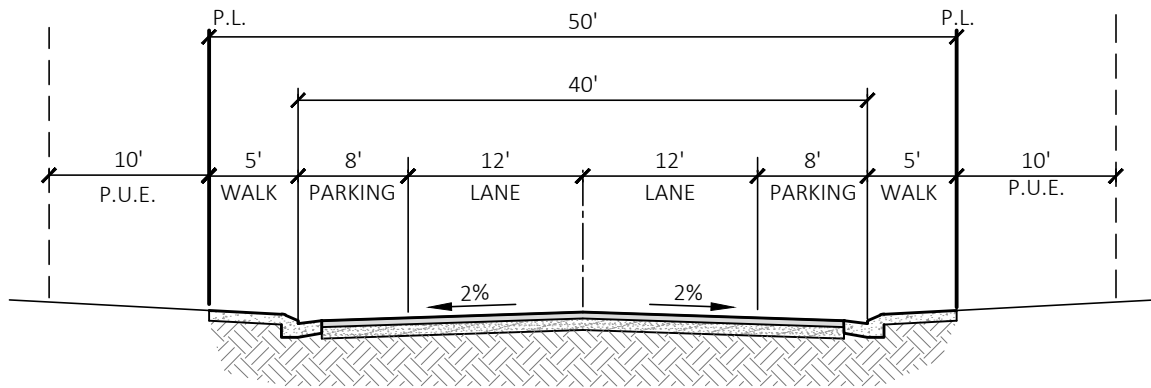

**LOCAL RESIDENTIAL**

NOTES:

1. CONSTRUCT DRIVE-OVER CURB AND GUTTER AND ATTACHED SIDEWALK PER DETAIL 2-L.
2. EDGE OF PAVING TO BE 1/4" HIGHER THAN LIP OF GUTTER.
3. TRAFFIC INDEX (T.I.) WILL BE DETERMINED BY CITY ENGINEER.
4. STREET SECTION TO BE DETERMINED ON RESISTANCE VALUE (R-VALUE) OF SUBGRADE MATERIAL.
5. 6" COMPACTION OF NATIVE MATERIAL TO CAL-TRANS STANDARDS MINIMUM RELATIVE COMPACTION IS 95%.
6. AGGREGATE SUB-BASE SHALL BE CLASS "B" 3/4" MAXIMUM GRADING AS PER CAL-TRANS STANDARDS.

APPROVED BY CITY COUNCIL:  
RESOLUTION: 2025-094

*Rob Marler*

ROB MARLER, P.E. - CITY ENGINEER

**LOCAL RESIDENTIAL**

CITY OF OAKDALE  
DEPARTMENT OF PUBLIC SERVICES

DATE: 09-15-25

DRAWING NO.

**2-A**

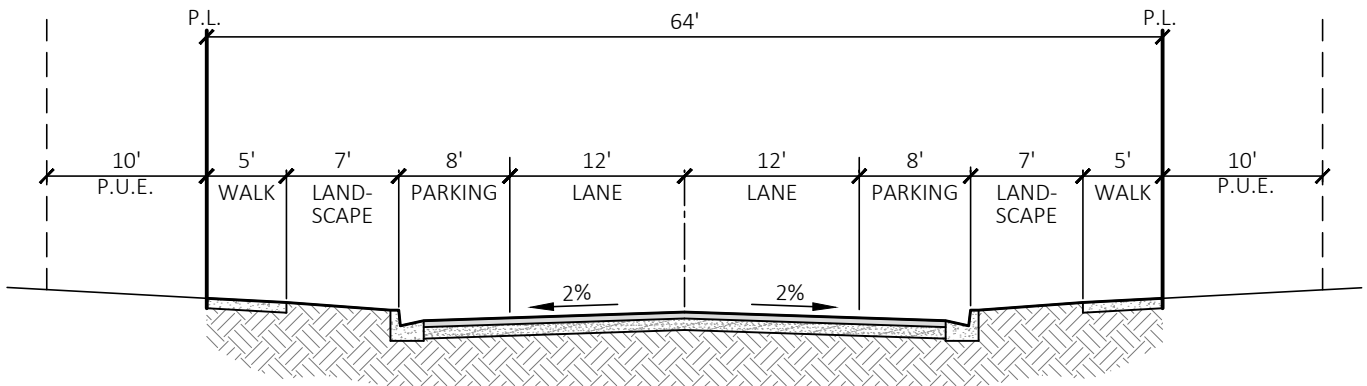

**FEATURE RESIDENTIAL**

NOTES:

1. CONSTRUCT STANDARD CURB AND GUTTER AND SEPARATED SIDEWALK PER DETAIL 2-K.
2. EDGE OF PAVING TO BE 1/4" HIGHER THAN LIP OF GUTTER.
3. TRAFFIC INDEX (T.I.) WILL BE DETERMINED BY CITY ENGINEER.
4. STREET SECTION TO BE DETERMINED ON RESISTANCE VALUE (R-VALUE) OF SUBGRADE MATERIAL.
5. 6" COMPACTION OF NATIVE MATERIAL TO CAL-TRANS STANDARDS MINIMUM RELATIVE COMPACTION IS 95%.
6. AGGREGATE SUB-BASE SHALL BE CLASS "B" 3/4" MAXIMUM GRADING AS PER CAL-TRANS STANDARDS.

APPROVED BY CITY COUNCIL:  
RESOLUTION: 2025-094

*Rob Marler*

ROB MARLER, P.E. - CITY ENGINEER

**FEATURE RESIDENTIAL**

CITY OF OAKDALE  
DEPARTMENT OF PUBLIC SERVICES

DATE: 09-15-25

DRAWING NO.

**2-B**

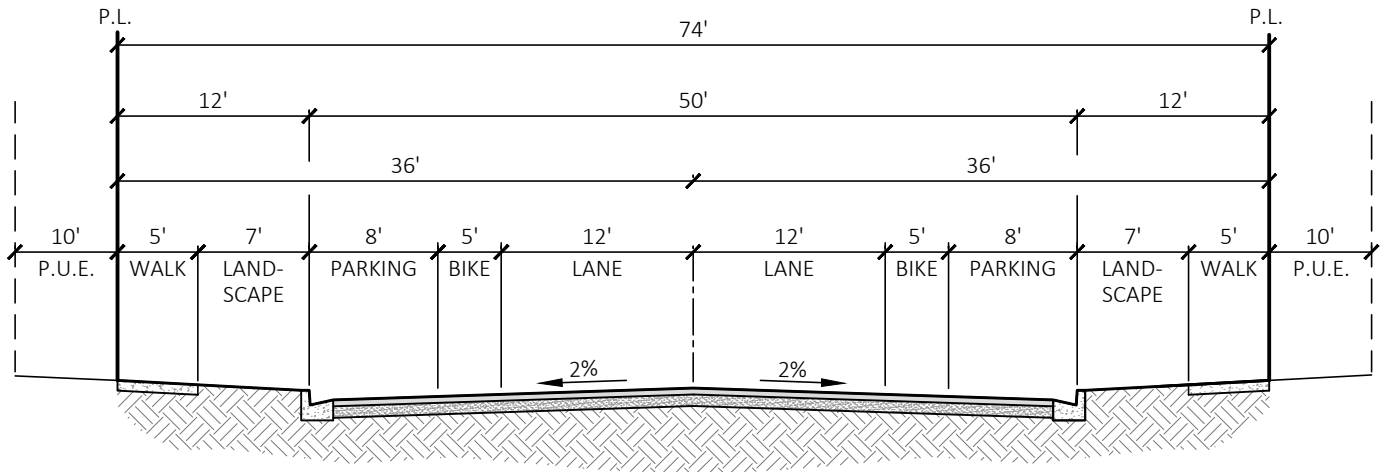

## COLLECTOR RESIDENTIAL

NOTES:

1. CONSTRUCT STANDARD CURB AND GUTTER AND SEPARATED SIDEWALK PER DETAIL 2-K.
2. EDGE OF PAVING TO BE 1/4" HIGHER THAN LIP OF GUTTER.
3. TRAFFIC INDEX (T.I.) WILL BE DETERMINED BY CITY ENGINEER.
3. STREET SECTION TO BE DETERMINED ON RESISTANCE VALUE (R-VALUE) OF SUBGRADE MATERIAL.
4. 6" COMPACTION OF NATIVE MATERIAL TO CAL-TRANS STANDARDS MINIMUM RELATIVE COMPACTION IS 95%.
5. AGGREGATE SUB-BASE SHALL BE CLASS "B" 3/4" MAXIMUM GRADING AS PER CAL-TRANS STANDARDS.

APPROVED BY CITY COUNCIL:  
RESOLUTION: 2025-094

*Rob Marler*

ROB MARLER, P.E. - CITY ENGINEER

## COLLECTOR RESIDENTIAL

CITY OF OAKDALE  
DEPARTMENT OF PUBLIC SERVICES

DATE: 09-15-25

DRAWING NO.

# 2-C

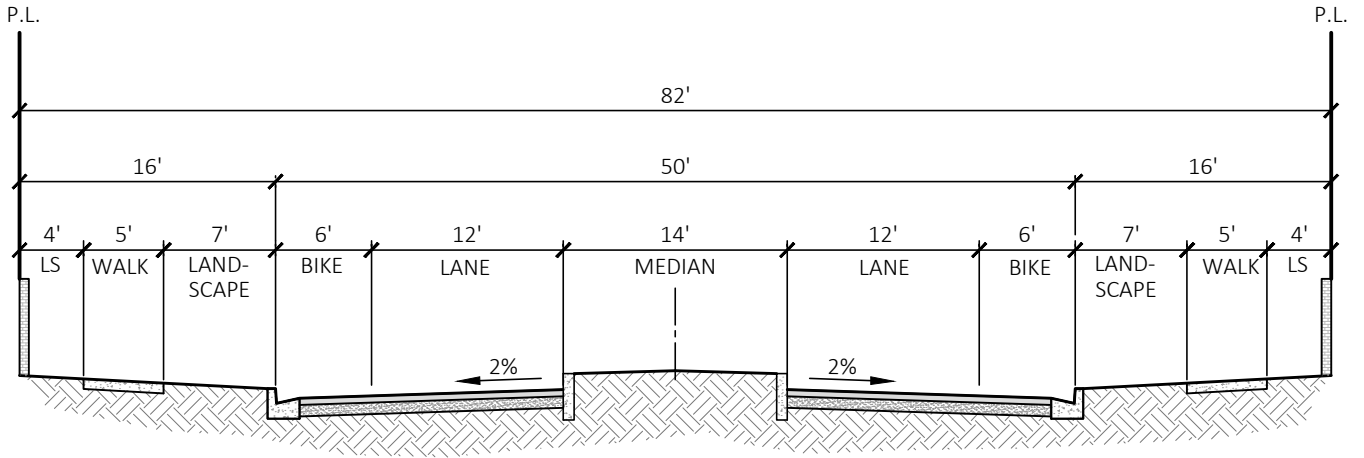

## 2-LANE ARTERIAL

NOTES:

1. CONSTRUCT STANDARD CURB AND GUTTER AND SEPARATED SIDEWALK PER DETAIL 2-K.
2. EDGE OF PAVING TO BE 1/4" HIGHER THAN LIP OF GUTTER.
3. TRAFFIC INDEX (T.I.) WILL BE DETERMINED BY CITY ENGINEER.
4. STREET SECTION TO BE DETERMINED ON RESISTANCE VALUE (R-VALUE) OF SUBGRADE MATERIAL.
5. 6" COMPACTION OF NATIVE MATERIAL TO CAL-TRANS STANDARDS MINIMUM RELATIVE COMPACTION IS 95%.
6. AGGREGATE SUB-BASE SHALL BE CLASS "B" 3/4" MAXIMUM GRADING AS PER CAL-TRANS STANDARDS.

APPROVED BY CITY COUNCIL:  
RESOLUTION: 2025-094

*Rob Marler*

ROB MARLER, P.E. - CITY ENGINEER

## 2-LANE ARTERIAL

CITY OF OAKDALE  
DEPARTMENT OF PUBLIC SERVICES

DATE: 09-15-25

DRAWING NO.

# 2-D

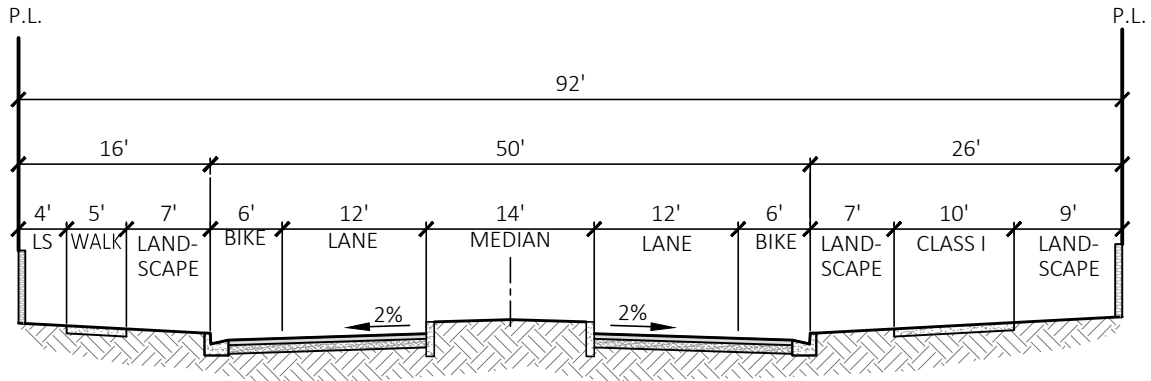

**2-LANE ARTERIAL**  
(WITH CLASS I BIKE PATH)

NOTES:

1. CONSTRUCT STANDARD CURB AND GUTTER AND SEPARATED SIDEWALK PER DETAIL 2-K.
2. EDGE OF PAVING TO BE 1/4" HIGHER THAN LIP OF GUTTER.
3. TRAFFIC INDEX (T.I.) WILL BE DETERMINED BY CITY ENGINEER.
4. STREET SECTION TO BE DETERMINED ON RESISTANCE VALUE (R-VALUE) OF SUBGRADE MATERIAL.
5. 6" COMPACTION OF NATIVE MATERIAL TO CAL-TRANS STANDARDS MINIMUM RELATIVE COMPACTION IS 95%.
6. AGGREGATE SUB-BASE SHALL BE CLASS "B" 3/4" MAXIMUM GRADING AS PER CAL-TRANS STANDARDS.

APPROVED BY CITY COUNCIL:  
RESOLUTION: 2025-094

*Rob Marler*

ROB MARLER, P.E. - CITY ENGINEER

**2-LANE ARTERIAL**  
(WITH CLASS I BIKE PATH)

CITY OF OAKDALE  
DEPARTMENT OF PUBLIC SERVICES

DATE: 09-15-25

DRAWING NO.

**2-E**

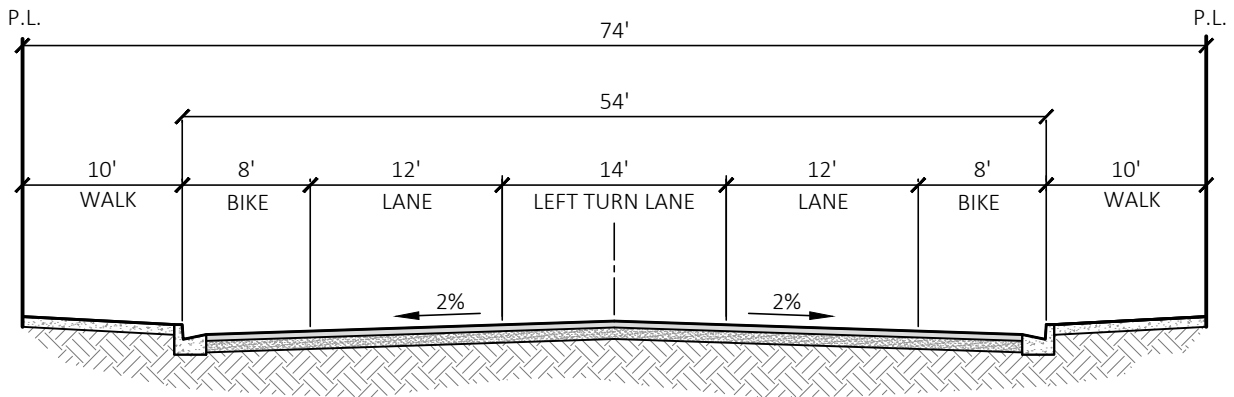

**2-LANE ARTERIAL**  
(COMMERCIAL FRONTAGE)

NOTES:

1. CONSTRUCT STANDARD CURB AND GUTTER AND ATTACHED SIDEWALK PER DETAIL 2-K.
2. EDGE OF PAVING TO BE 1/4" HIGHER THAN LIP OF GUTTER.
3. TRAFFIC INDEX (T.I.) WILL BE DETERMINED BY CITY ENGINEER.
4. STREET SECTION TO BE DETERMINED ON RESISTANCE VALUE (R-VALUE) OF SUBGRADE MATERIAL.
5. 6" COMPACTION OF NATIVE MATERIAL TO CAL-TRANS STANDARDS MINIMUM RELATIVE COMPACTION IS 95%.
6. AGGREGATE SUB-BASE SHALL BE CLASS "B" 3/4" MAXIMUM GRADING AS PER CAL-TRANS STANDARDS.

APPROVED BY CITY COUNCIL:  
RESOLUTION: 2025-094

*Rob Marler*

ROB MARLER, P.E. - CITY ENGINEER

**2-LANE ARTERIAL**  
(COMMERCIAL FRONTAGE)

CITY OF OAKDALE  
DEPARTMENT OF PUBLIC SERVICES

DATE: 09-15-25

DRAWING NO.

**2-F**

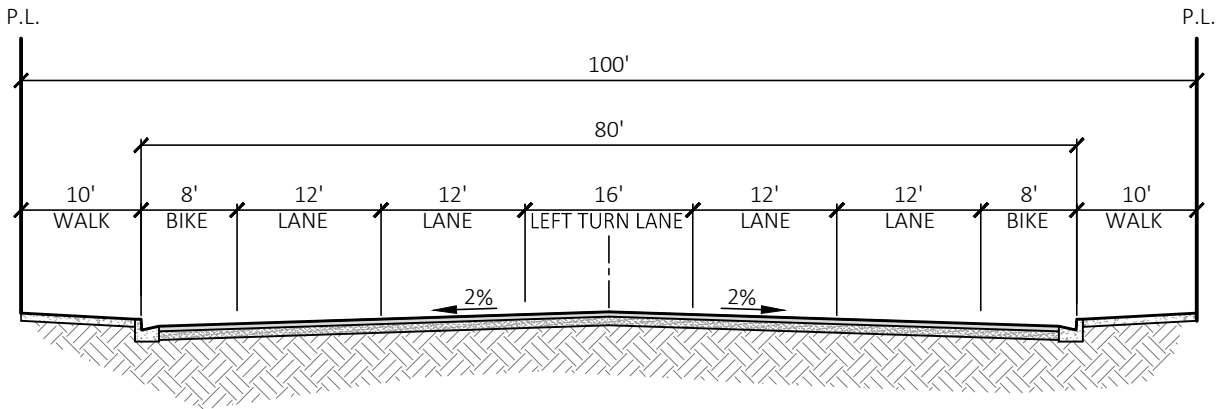

**4-LANE ARTERIAL**  
(COMMERCIAL FRONTAGE)

NOTES:

1. CONSTRUCT STANDARD CURB AND GUTTER AND ATTACHED SIDEWALK PER DETAIL 2-K.
2. EDGE OF PAVING TO BE 1/4" HIGHER THAN LIP OF GUTTER.
3. TRAFFIC INDEX (T.I.) WILL BE DETERMINED BY CITY ENGINEER.
4. STREET SECTION TO BE DETERMINED ON RESISTANCE VALUE (R-VALUE) OF SUBGRADE MATERIAL.
5. 6" COMPACTION OF NATIVE MATERIAL TO CAL-TRANS STANDARDS MINIMUM RELATIVE COMPACTION IS 95%.
6. AGGREGATE SUB-BASE SHALL BE CLASS "B" 3/4" MAXIMUM GRADING AS PER CAL-TRANS STANDARDS.

APPROVED BY CITY COUNCIL: RESOLUTION: 2025-094	<b>4-LANE ARTERIAL</b> <b>(COMMERCIAL FRONTAGE)</b>	DATE: 09-15-25
		DRAWING NO.
ROB MARLER, P.E. - CITY ENGINEER	CITY OF OAKDALE DEPARTMENT OF PUBLIC SERVICES	<b>2-G</b>

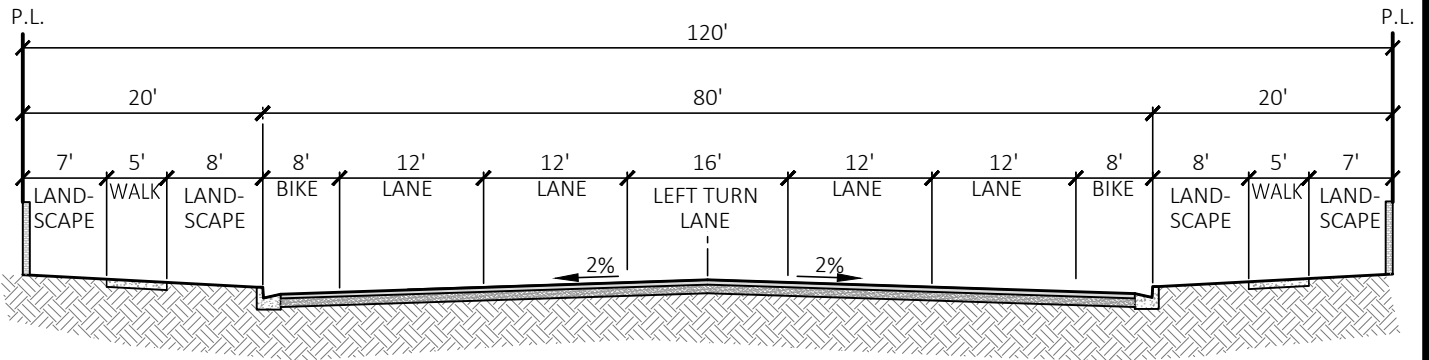

**4-LANE ARTERIAL**  
(ADJACENT TO RESIDENTIAL)

NOTES:

1. CONSTRUCT STANDARD CURB AND GUTTER AND SEPARATED SIDEWALK PER DETAIL 2-K.
2. EDGE OF PAVING TO BE 1/4" HIGHER THAN LIP OF GUTTER.
3. TRAFFIC INDEX (T.I.) WILL BE DETERMINED BY CITY ENGINEER.
4. STREET SECTION TO BE DETERMINED ON RESISTANCE VALUE (R-VALUE) OF SUBGRADE MATERIAL.
5. 6" COMPACTION OF NATIVE MATERIAL TO CAL-TRANS STANDARDS MINIMUM RELATIVE COMPACTION IS 95%.
6. AGGREGATE SUB-BASE SHALL BE CLASS "B" 3/4" MAXIMUM GRADING AS PER CAL-TRANS STANDARDS.

APPROVED BY CITY COUNCIL:  
RESOLUTION: 2025-094

*Rob Marler*

ROB MARLER, P.E. - CITY ENGINEER

**4-LANE ARTERIAL**  
(ADJACENT TO RESIDENTIAL)

CITY OF OAKDALE  
DEPARTMENT OF PUBLIC SERVICES

DATE: 09-15-25

DRAWING NO.

**2-H**

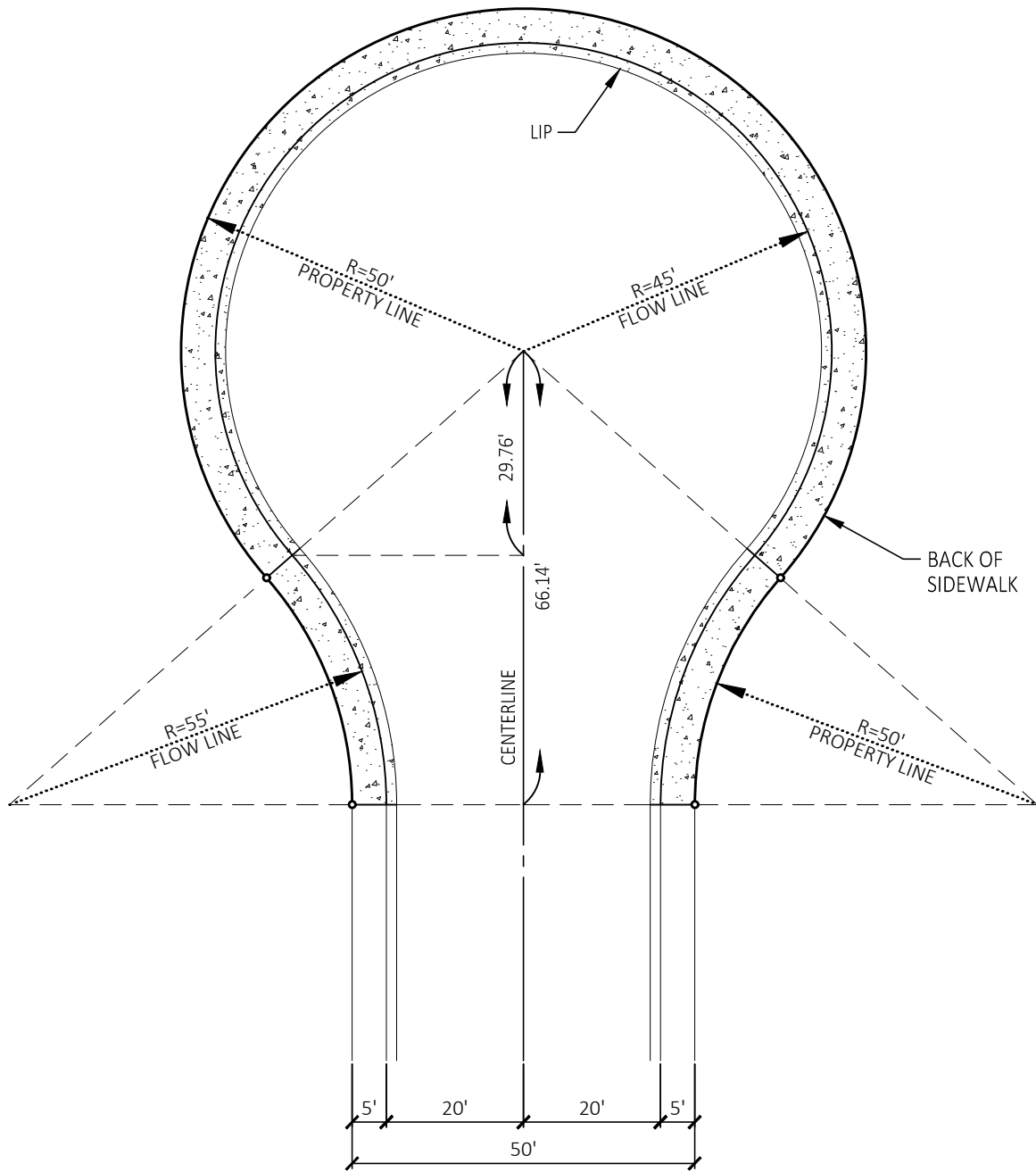

NOTES:

1. MAXIMUM LENGTH OF CUL-DE-SAC TO BE 500 FEET, MEASURED FROM THE CENTERLINE OF THE INTERSECTING STREET TO THE CUL-DE-SAC RADIUS POINT.

APPROVED BY CITY COUNCIL:  
RESOLUTION: 2025-094

*Rob Marler*

ROB MARLER, P.E. - CITY ENGINEER

# CUL-DE-SAC

CITY OF OAKDALE  
DEPARTMENT OF PUBLIC SERVICES

DATE: 09-15-25

DRAWING NO.

# 2-1

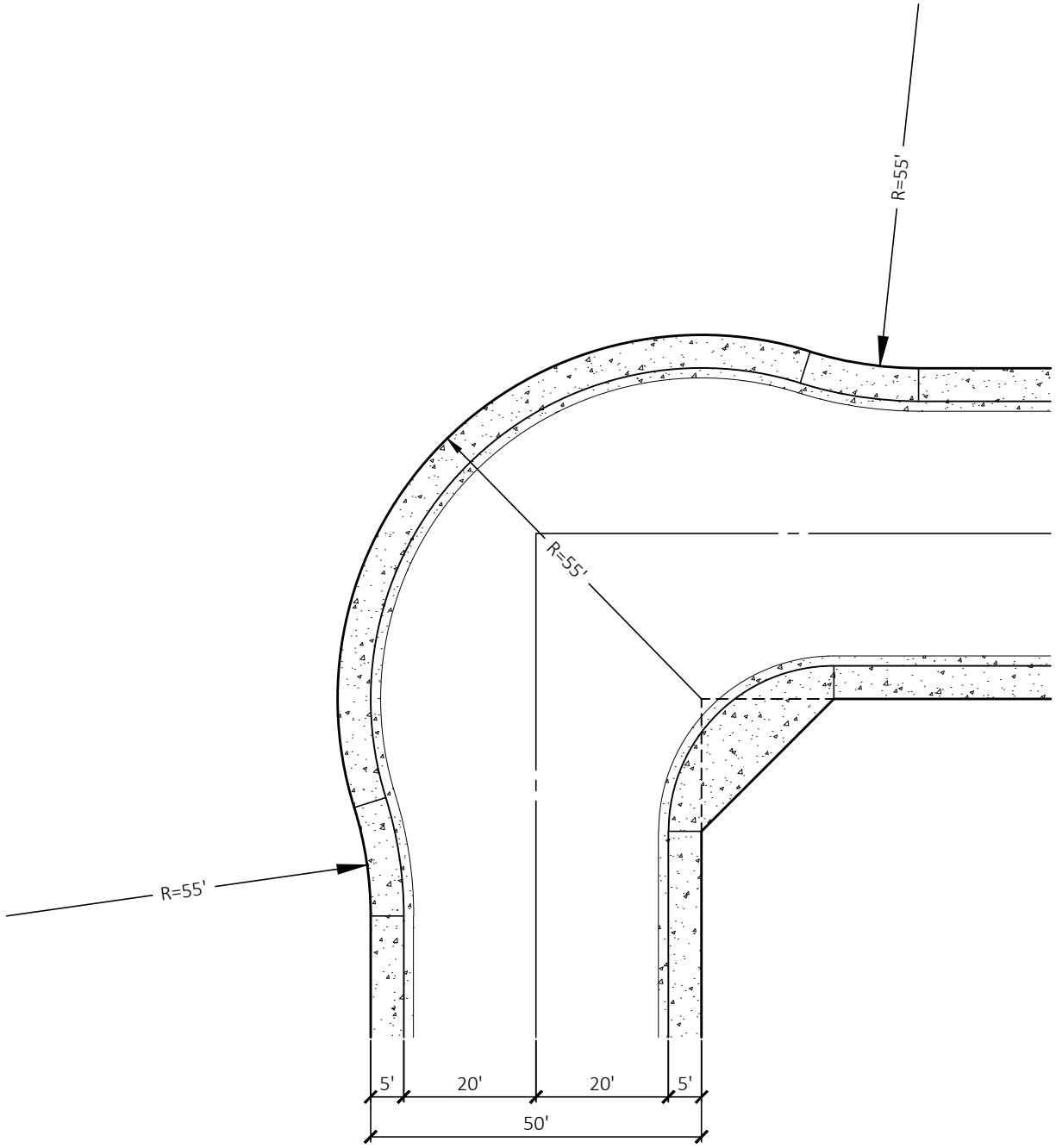

NOTES:

1. KNUCKLE RADII FOR INTERSECTING STREETS GREATER THAN 50' IN WIDTH ARE TO BE ESTABLISHED INDIVIDUALLY AS DETERMINED BY THE CITY ENGINEER.
2. INTERSECTION KNUCKLES SHALL BE INSTALLED WHERE THE CENTERLINE RADIUS IS LESS THAN 125'.

APPROVED BY CITY COUNCIL: RESOLUTION: 2025-094	<h1 style="margin: 0;">STREET KNUCKLE</h1>	DATE: 09-15-25
		DRAWING NO. <h2 style="margin: 0;">2-J</h2>
ROB MARLER, P.E. - CITY ENGINEER	CITY OF OAKDALE DEPARTMENT OF PUBLIC SERVICES	

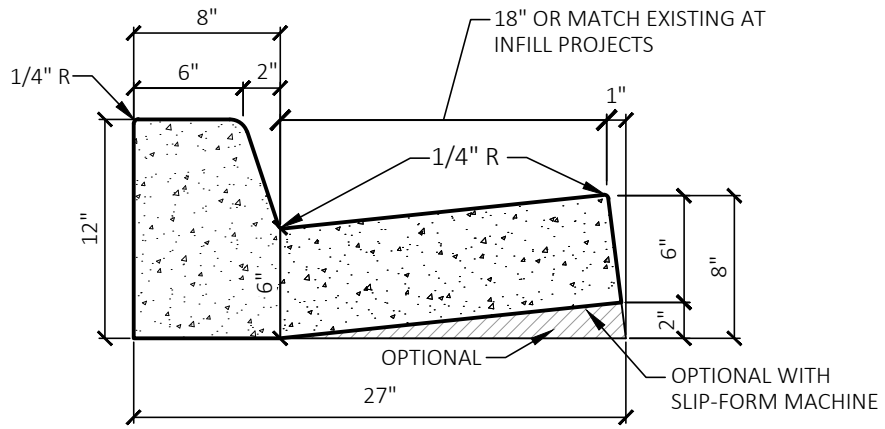

**VERTICAL CURB & GUTTER**

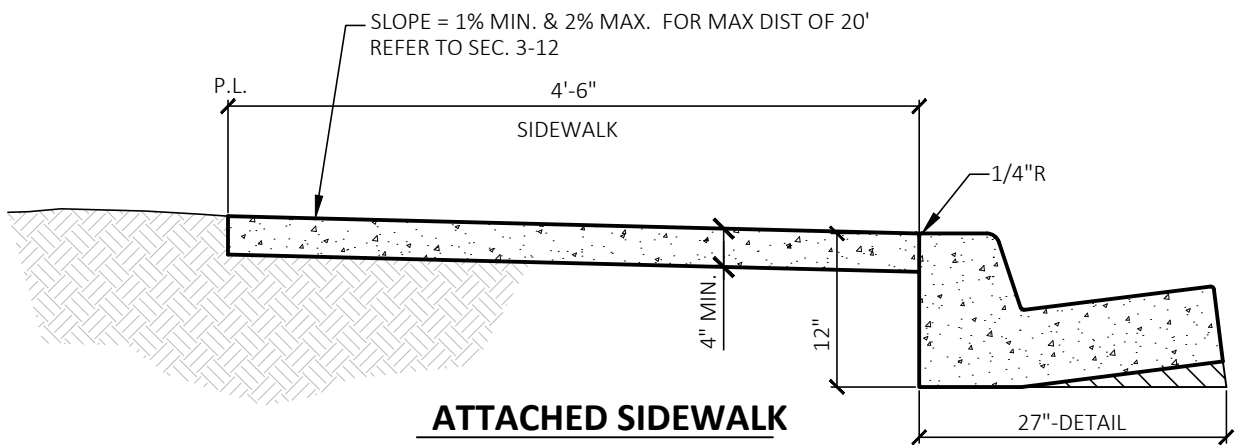

**ATTACHED SIDEWALK**

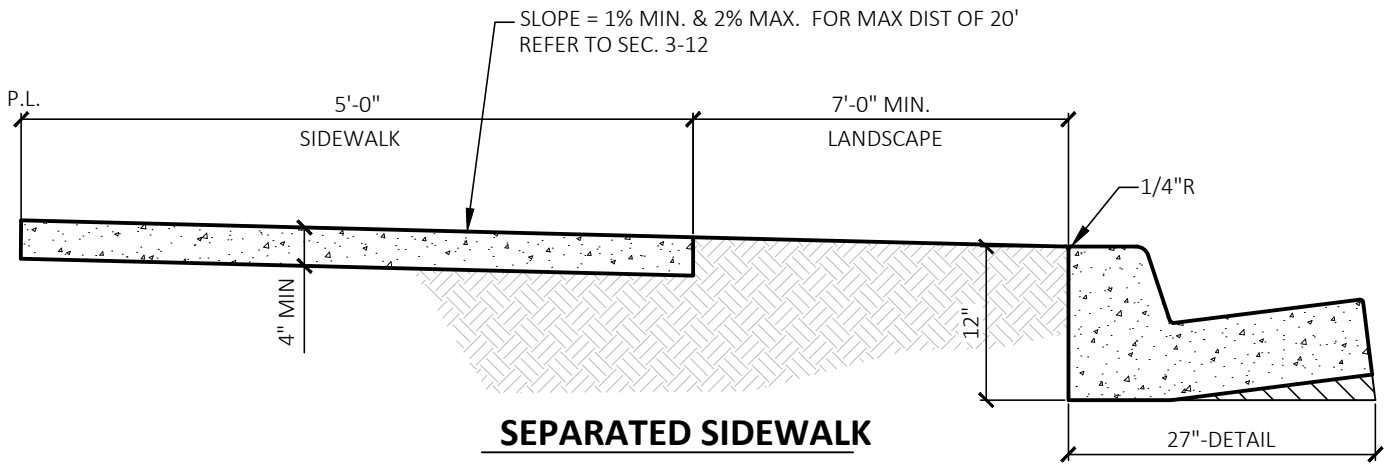

**SEPARATED SIDEWALK**

NOTES:

1. ALL SIDEWALK REPLACEMENTS TO HAVE 1/2" SMOOTH DOWELS, NO REBAR.
2. ALL SIDEWALKS SHALL BE 4" MIN. THICK.

APPROVED BY CITY COUNCIL:  
RESOLUTION: 2025-094

*Rob Marler*

ROB MARLER, P.E. - CITY ENGINEER

**VERTICAL CURB & GUTTER**

CITY OF OAKDALE  
DEPARTMENT OF PUBLIC SERVICES

DATE: 09-15-25

DRAWING NO.

**2-K**

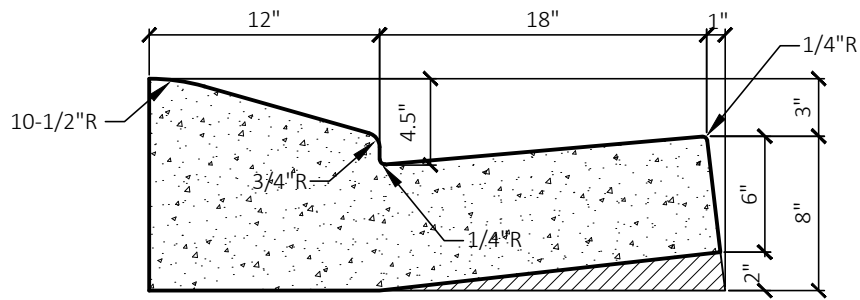

### DRIVE-OVER CURB & GUTTER

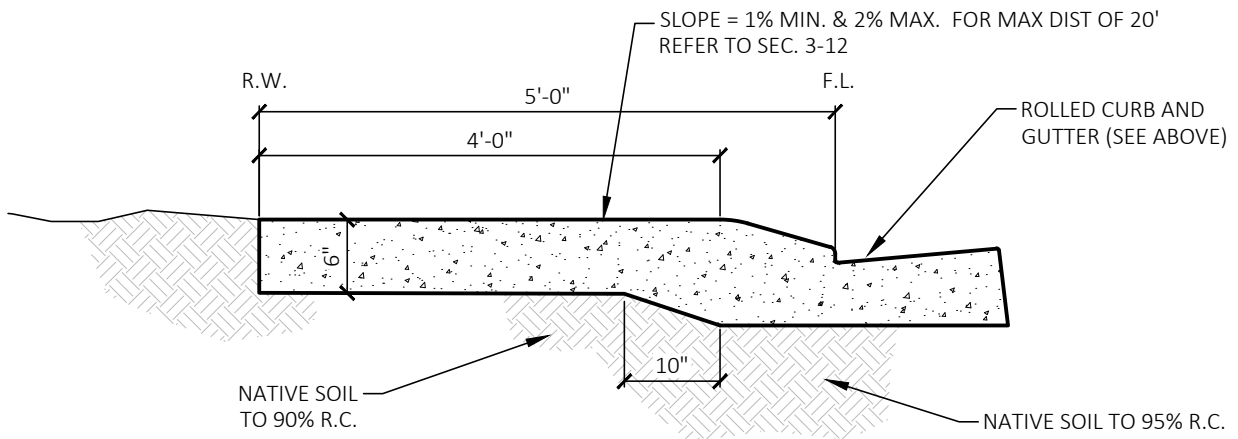

### ATTACHED SIDEWALK

NOTES:

1. CURB, GUTTER, AND SIDEWALK CONSTRUCTION SHALL CONFORM TO SECTION 73, STANDARD SPECIFICATIONS, CALIFORNIA DEPARTMENT OF TRANSPORTATION (CALTRANS), EXCEPT AS MODIFIED HEREIN.
2. CONCRETE SHALL BE CLASS B, PER CALTRANS SECTION 90.
3. EXPANSION JOINTS AND WEAKENED PLANE JOINTS SHALL BE INSTALLED AS INDICATED ON THE PLANS OR STANDARD DETAILS.
4. DURING CONSTRUCTION OF GUTTERS, WATER SHALL BE USED TO INSURE PROPER DRAINAGE ALONG THE FLOWLINE.
5. THE CONCRETE SURFACE SHALL BE FREE OF BLEMISHES AND NOT VARY MORE THAN 1/4" FROM A 10' STRAIGHT EDGE.
6. CONCRETE SHALL HAVE A LIGHT BROOM FINISH AND AN IMPERVIOUS MEMBRANE OR SPRAY CURE. 1 GAL/150 SF PIGMENTED CURING COMP ASTM C309 TYPE Z, CLASS A OR B. APPLY IMMEDIATELY AFTER MOISTURE SHEEN DISAPPEARS.
7. DRIVE-OVER CURB & GUTTER AND SIDEWALK SHALL BE POURED MONOLITHICALLY.

APPROVED BY CITY COUNCIL:  
RESOLUTION: 2025-094

*Rob Marler*

ROB MARLER, P.E. - CITY ENGINEER

## DRIVE-OVER CURB & GUTTER

CITY OF OAKDALE  
DEPARTMENT OF PUBLIC SERVICES

DATE: 09-15-25

DRAWING NO.

**2-L**

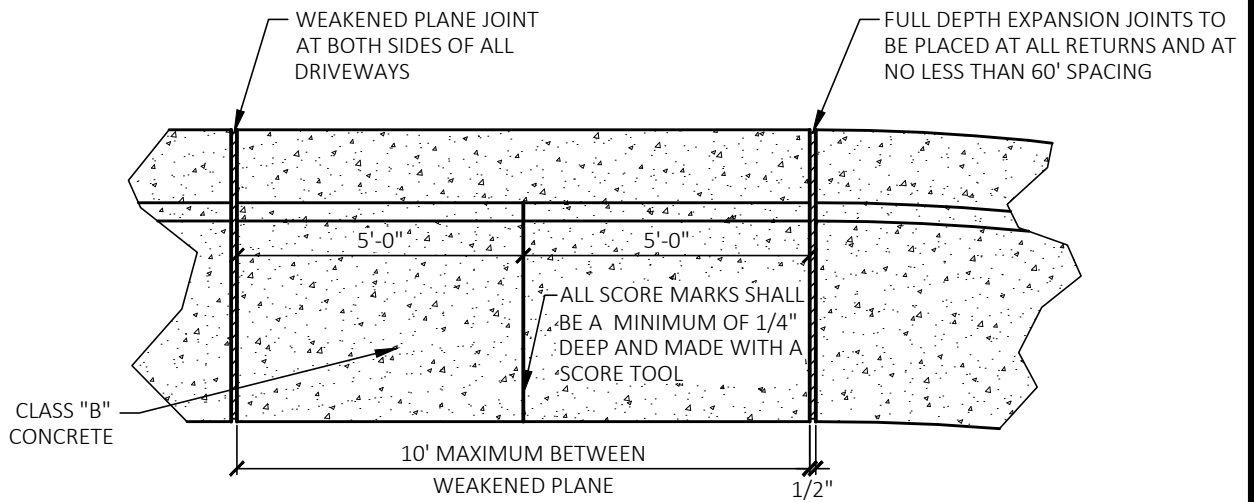

**TYPICAL PLAN**

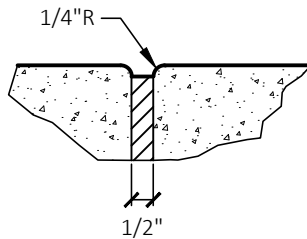

**EXPANSION JOINT DETAIL**

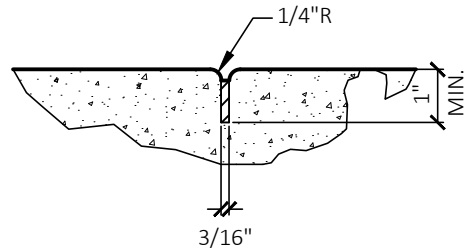

**WEAKENED PLANE JOINT DETAIL**

APPROVED BY CITY COUNCIL:  
RESOLUTION: 2025-094

*Rob Marler*

ROB MARLER, P.E. - CITY ENGINEER

**SIDEWALK JOINTS**

CITY OF OAKDALE  
DEPARTMENT OF PUBLIC SERVICES

DATE: 09-15-25

DRAWING NO.

**2-M**

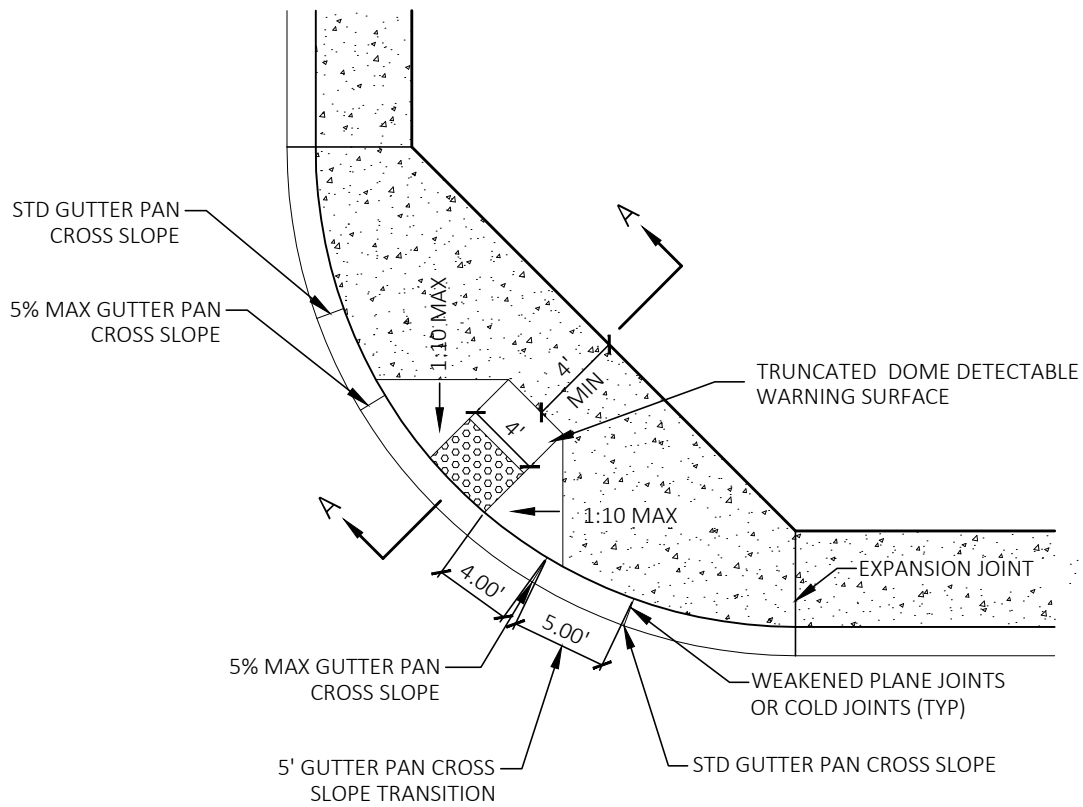

**PLAN VIEW**

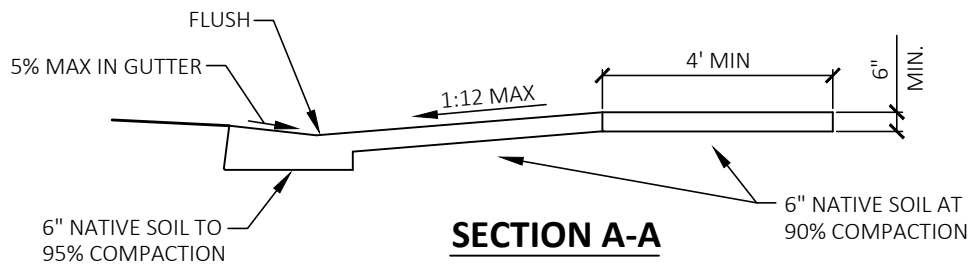

**SECTION A-A**

NOTES:

1. THE LOWER END OF THE RAMP SHALL BE FLUSH WITH THE GUTTER PAN.
2. TRANSITION GUTTER PAN CROSS SLOPE TO 5%, MIN 4' OUTSIDE OF BOTTOM OF RAMP.
3. IF THE DISTANCE FROM THE BACK OF THE SIDEWALK TO THE BACK OF THE RAMP IS LESS THAN 4 FEET, THEN THE SLOPE OF THE FLARED SIDES SHALL NOT EXCEED 1:12.

APPROVED BY CITY COUNCIL:  
RESOLUTION: 2025-094

*Rob Marler*

ROB MARLER, P.E. - CITY ENGINEER

**PEDESTRIAN RAMP  
CASE "A"**

CITY OF OAKDALE  
DEPARTMENT OF PUBLIC SERVICES

DATE: 09-15-25

DRAWING NO.

**2-N**

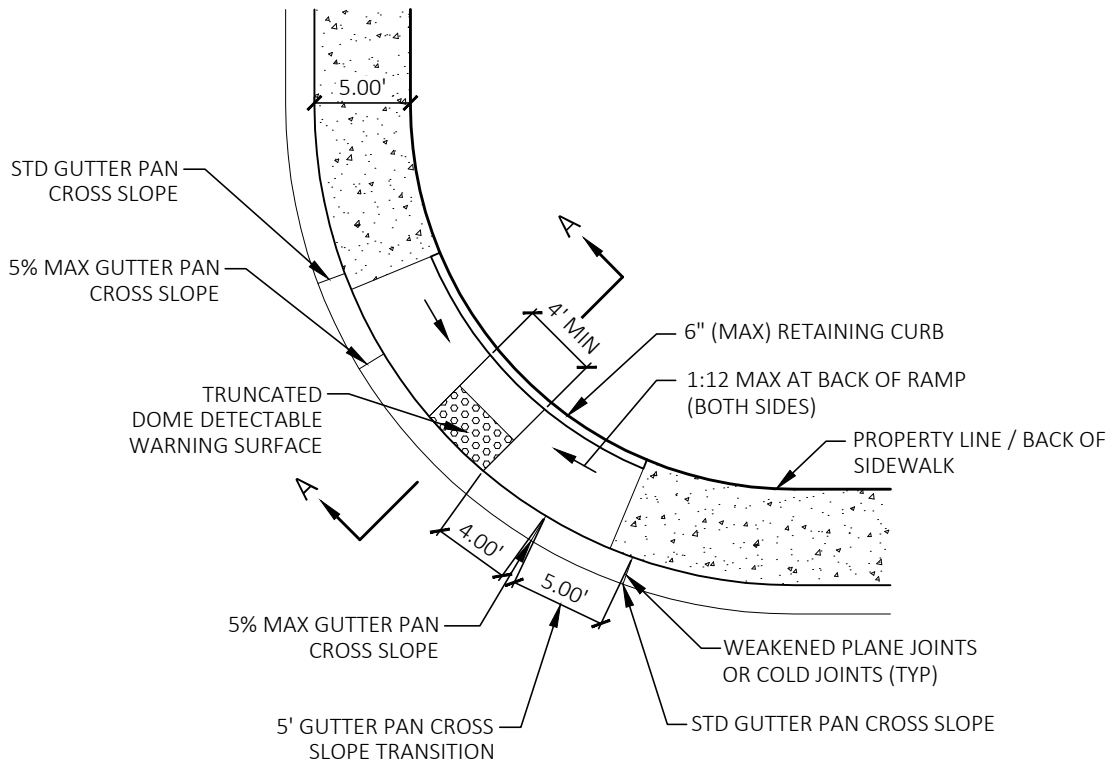

**PLAN VIEW**

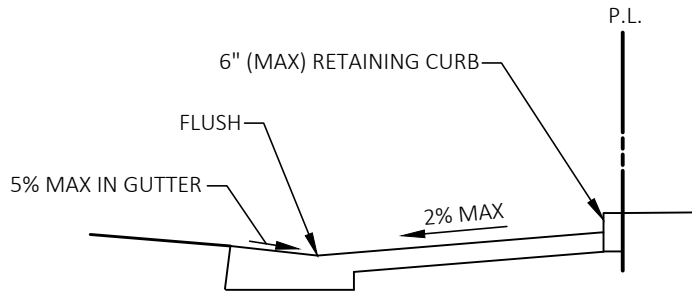

**SECTION A-A**

NOTES:

1. THE LOWER END OF THE RAMP SHALL BE FLUSH WITH THE GUTTER PAN.
2. TRANSITION GUTTER PAN CROSS SLOPE TO 5%, MIN 4' OUTSIDE OF BOTTOM OF RAMP.

APPROVED BY CITY COUNCIL:  
RESOLUTION: 2025-094

*Rob Marler*

ROB MARLER, P.E. - CITY ENGINEER

**PEDESTRIAN RAMP  
CASE "B"**

CITY OF OAKDALE  
DEPARTMENT OF PUBLIC SERVICES

DATE: 09-15-25

DRAWING NO.

**2-0**

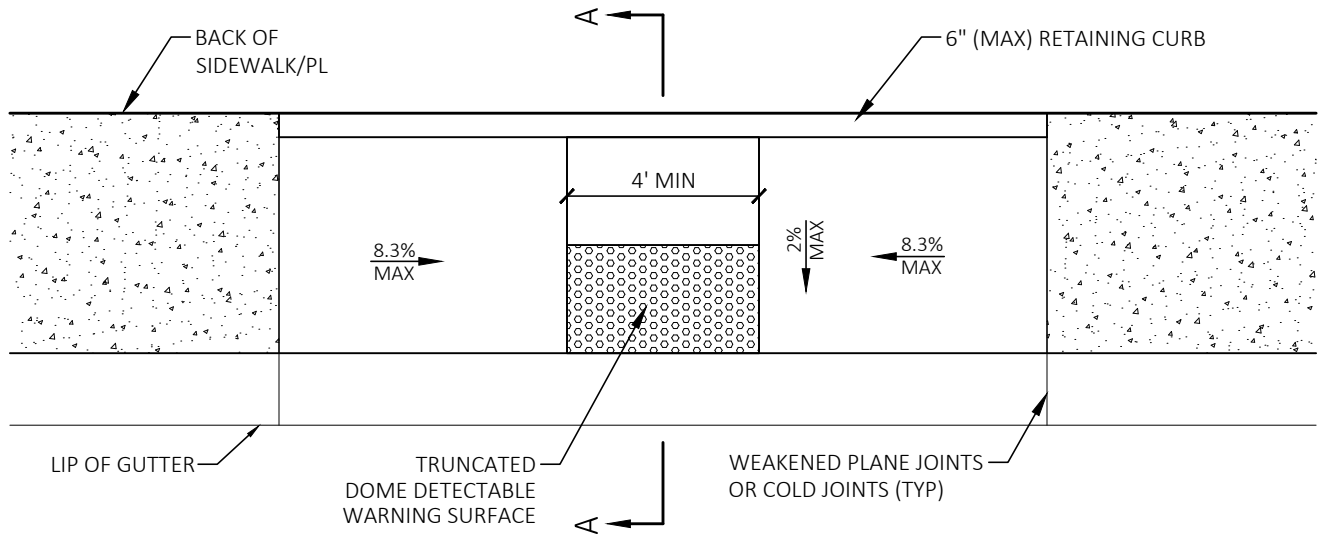

**PLAN VIEW**

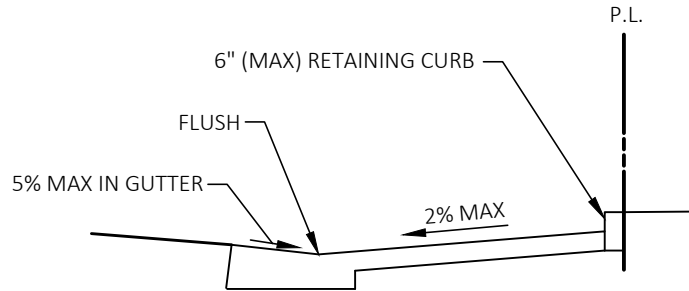

**SECTION A-A**

NOTES:

1. THE LOWER END OF THE RAMP SHALL BE FLUSH WITH THE GUTTER PAN.
2. TRANSITION GUTTER PAN CROSS SLOPE TO 5%, MIN 4' OUTSIDE OF BOTTOM OF RAMP.

APPROVED BY CITY COUNCIL:  
RESOLUTION: 2025-094

*Rob Marler*

ROB MARLER, P.E. - CITY ENGINEER

**PEDESTRIAN RAMP  
CASE "C"**

CITY OF OAKDALE  
DEPARTMENT OF PUBLIC SERVICES

DATE: 09-15-25

DRAWING NO.

**2-P**

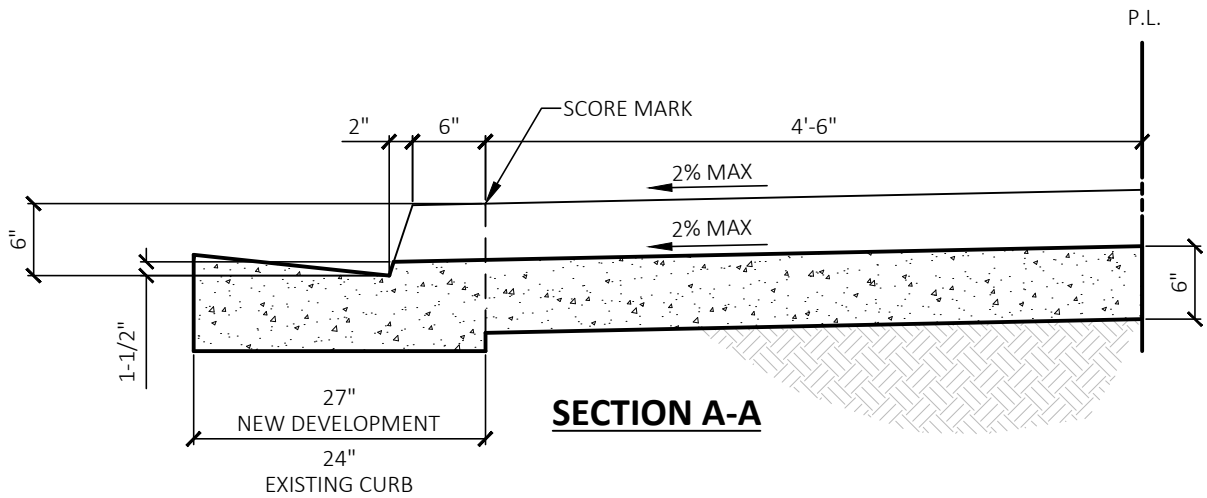
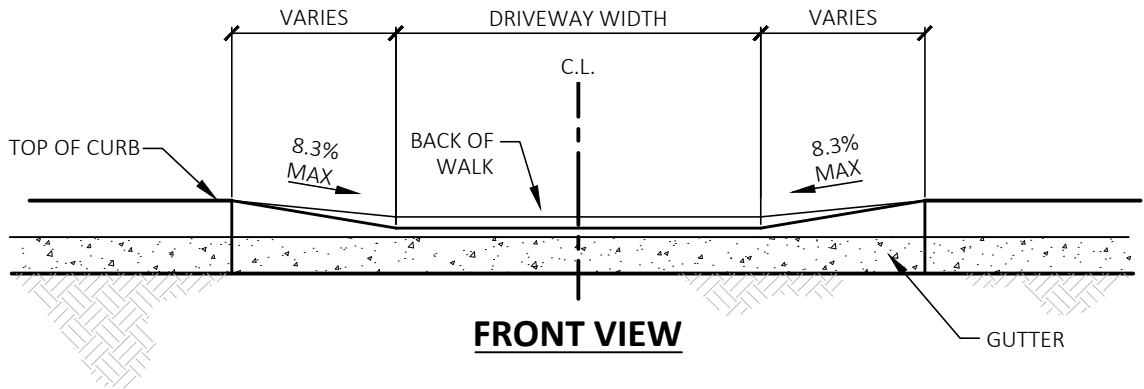
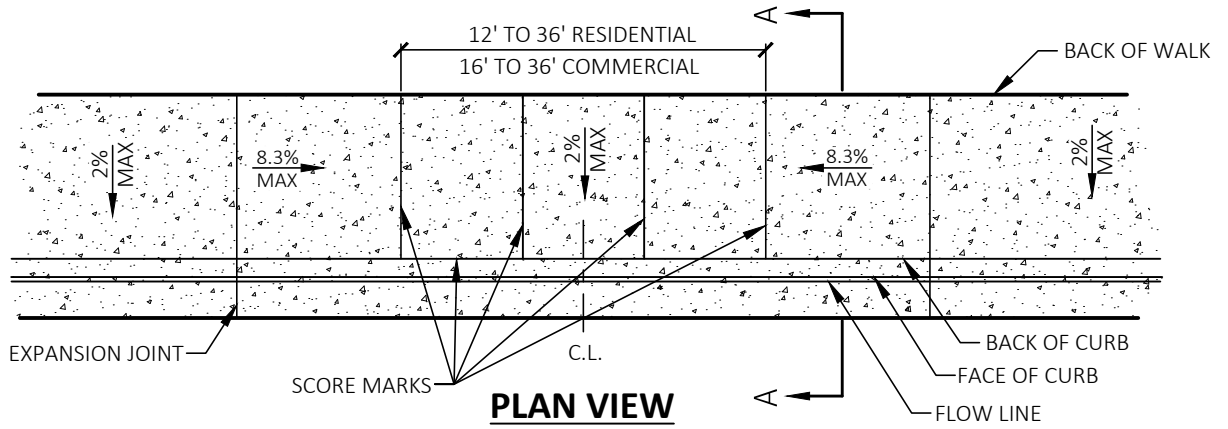

NOTES:

1. WEAKENED PLANE JOINT TO BE ADDED AT THE CENTER OF THE APPROACH IF IT IS OVER 20' WIDE.
2. THE SOIL BASE SHALL BE FIRM WITH NO WET OR SOFT SPOTS.
3. SIDEWALK PORTION AT COMMERCIAL DRIVEWAYS IS TO HAVE #10X10X6X6 WWF.

APPROVED BY CITY COUNCIL:  
RESOLUTION: 2025-094

*Rob Marler*

ROB MARLER, P.E. - CITY ENGINEER

# DRIVEWAY - CASE "A"

CITY OF OAKDALE  
DEPARTMENT OF PUBLIC SERVICES

DATE: 09-15-25

DRAWING NO.

## 2-Q

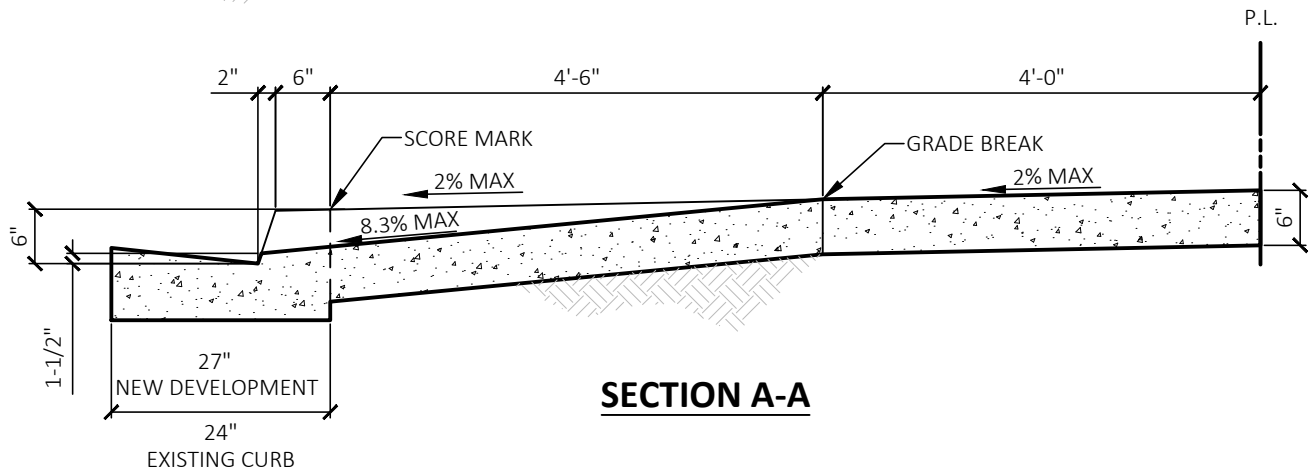
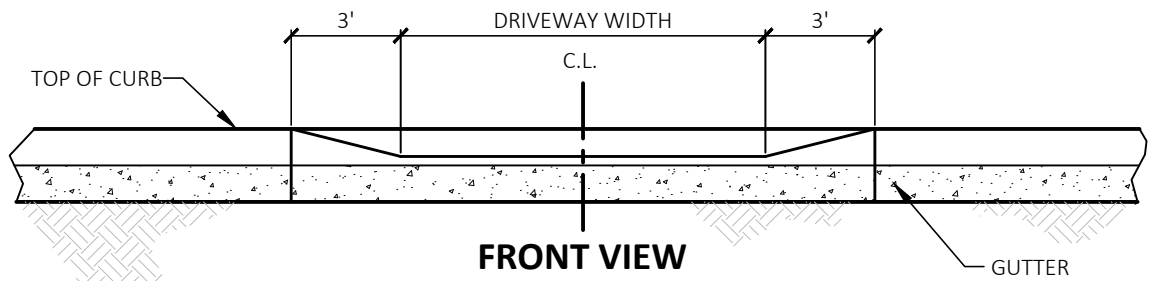
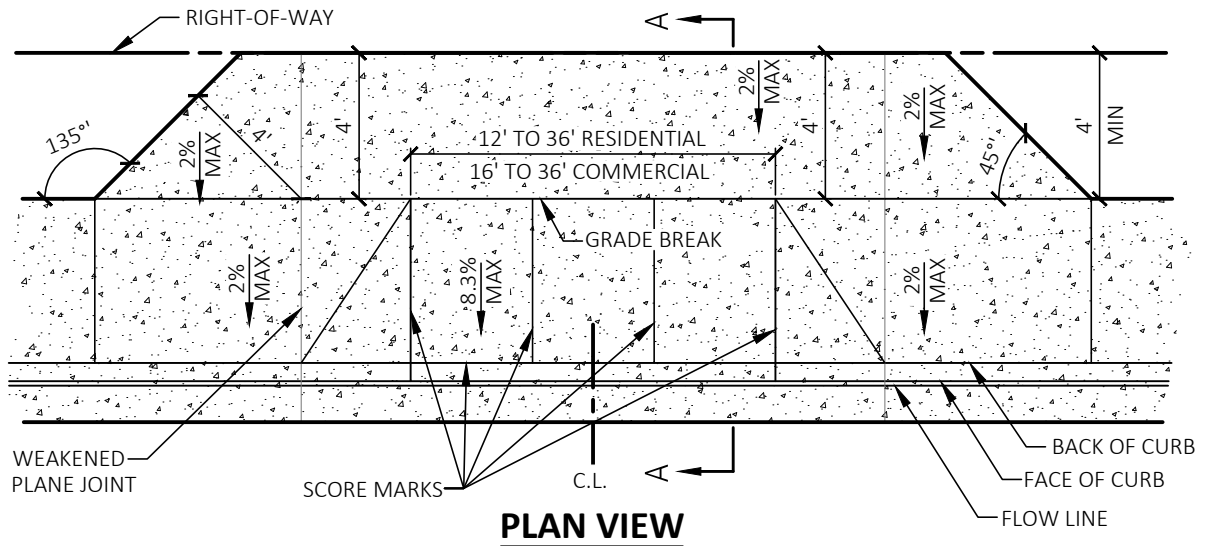

NOTES:

1. WEAKENED PLANE JOINT TO BE ADDED AT THE CENTER OF THE APPROACH IF IT IS OVER 20' WIDE.
2. THE SOIL BASE SHALL BE FIRM WITH NO WET OR SOFT SPOTS.
3. SIDEWALK PORTION AT COMMERCIAL DRIVEWAYS IS TO HAVE #10X10X6X6 WWF.

APPROVED BY CITY COUNCIL:  
RESOLUTION: 2025-094

*Rob Marler*

ROB MARLER, P.E. - CITY ENGINEER

**DRIVEWAY - CASE "B"**

CITY OF OAKDALE  
DEPARTMENT OF PUBLIC SERVICES

DATE: 09-15-25

DRAWING NO.

**2-R**

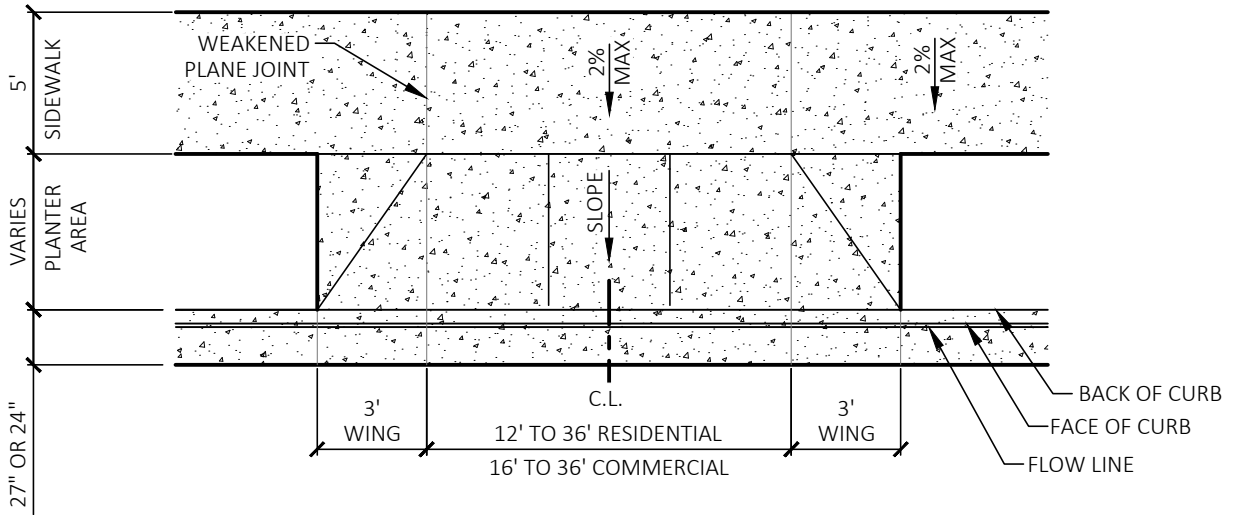

**PLAN VIEW**

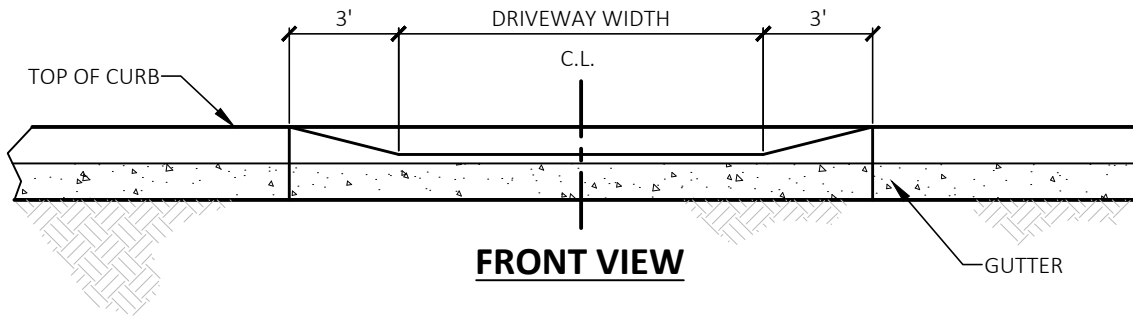

**FRONT VIEW**

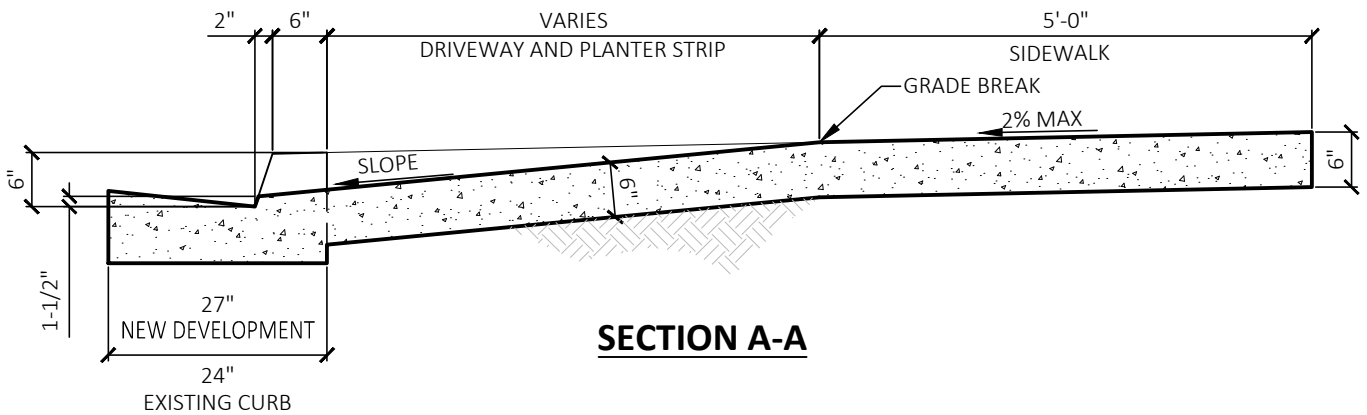

**SECTION A-A**

NOTES:

1. WEAKENED PLANE JOINT TO BE ADDED AT THE CENTER OF THE APPROACH IF IT IS OVER 20' WIDE.
2. THE SOIL BASE SHALL BE FIRM WITH NO WET OR SOFT SPOTS.
3. SIDEWALK PORTION AT COMMERCIAL DRIVEWAYS IS TO HAVE #10X10X6X6 WWF.

APPROVED BY CITY COUNCIL:  
RESOLUTION: 2025-094

*Rob Marler*

ROB MARLER, P.E. - CITY ENGINEER

**DRIVEWAY - CASE "C"**

CITY OF OAKDALE  
DEPARTMENT OF PUBLIC SERVICES

DATE: 09-15-25

DRAWING NO.

**2-S**

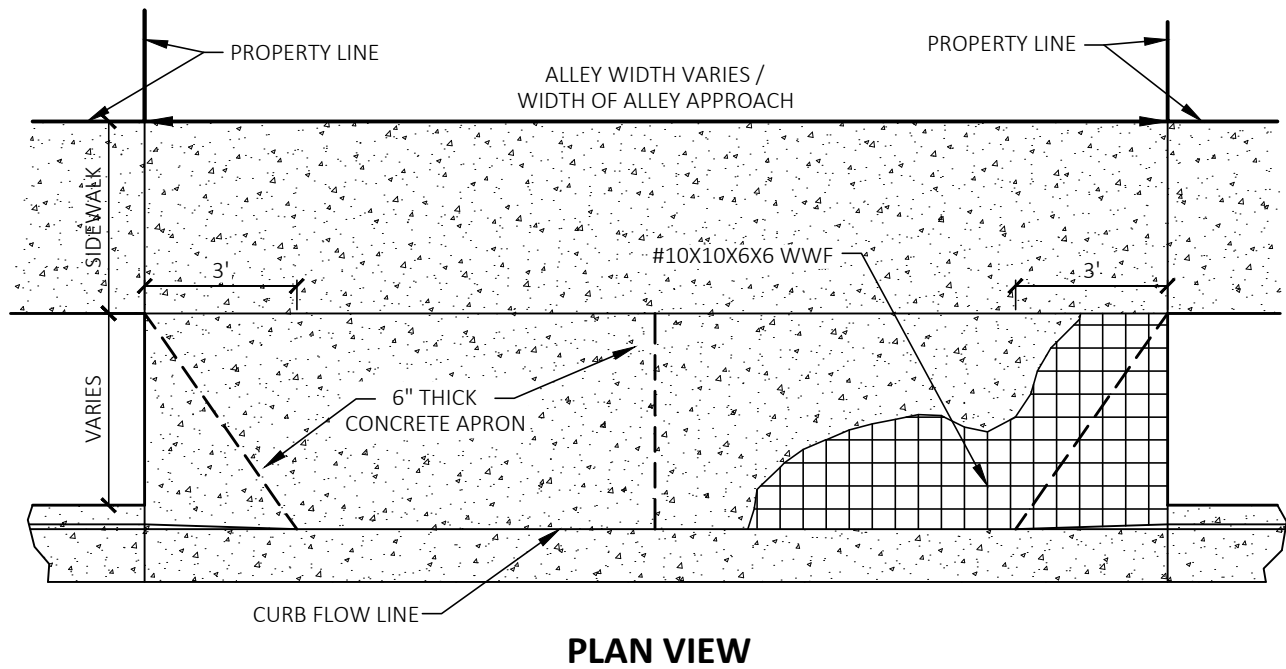
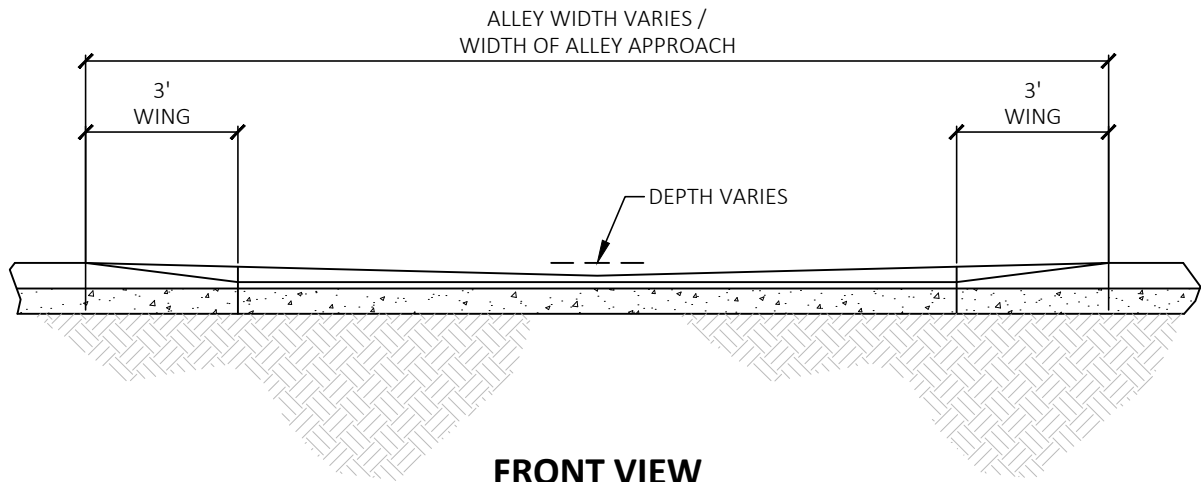

NOTES:

1. WEAKENED PLANE JOINT TO BE ADDED AT THE CENTER OF THE APPROACH IF IT IS OVER 20' WIDE.
2. THE SOIL BASE SHALL BE FIRM WITH NO WET OR SOFT SPOTS.
3. SIDEWALK PORTION AT ALLEY DRIVEWAYS TO BE 6" THICK.
4. SIDEWALK PORTION AT ALLEY DRIVEWAYS IS TO HAVE #10X10X6X6 WWF.

APPROVED BY CITY COUNCIL:  
RESOLUTION: 2025-094

*Rob Marler*

ROB MARLER, P.E. - CITY ENGINEER

**ALLEY APPROACH**

CITY OF OAKDALE  
DEPARTMENT OF PUBLIC SERVICES

DATE: 09-15-25

DRAWING NO.

**2-T**



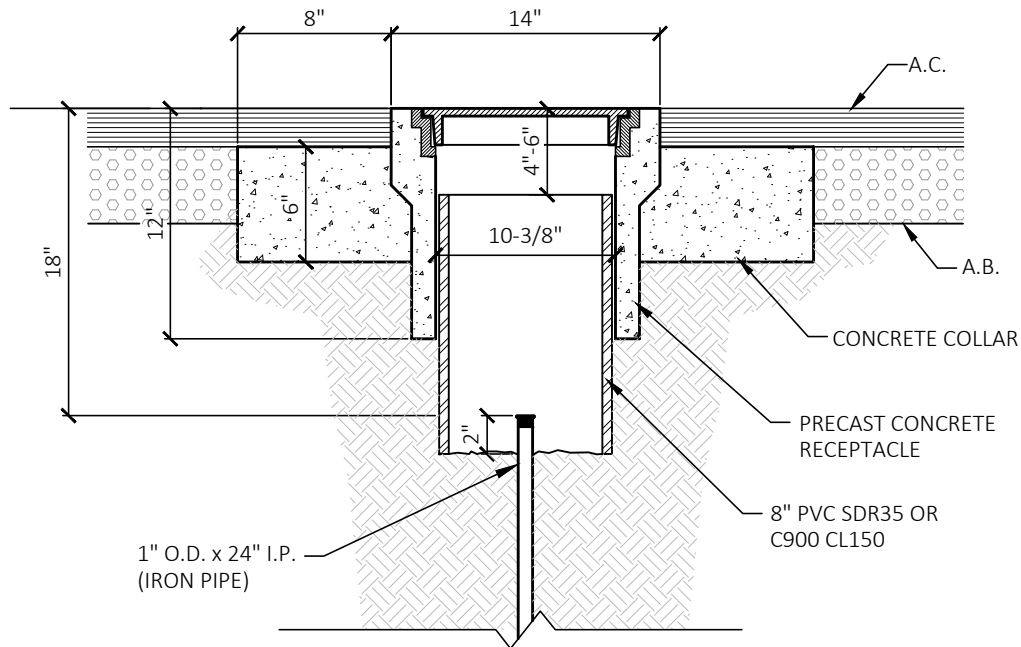

NOTES:

1. SET MONUMENT, FRAME AND COVER AFTER PAVEMENT IS IN PLACE.
2. MONUMENT FRAMES AND COVERS SHALL BE TOUGH GREY IRON CASTING CONFORMING TO THE LATEST A.S.T.M. REQUIREMENTS. EACH COVER SHALL BE GROUND OR OTHERWISE FINISHED SO THAT IT WILL FIT IT'S FRAME WITHOUT ROCKING.
3. FRAME AND COVER TO BE CHRISTY G-5 WITH C-275 LID MARKED "MONUMENT".
4. MONUMENTS TO BE SET AT ALL INTERSECTIONS, ENDS OF CUL-DE-SACS, AT B.C. & E.C. OF CURVES AND AS DIRECTED BY THE CITY ENGINEER.

APPROVED BY CITY COUNCIL:  
RESOLUTION: 2025-094

*Rob Marler*

ROB MARLER, P.E. - CITY ENGINEER

# MONUMENT AND RECEPTACLE

CITY OF OAKDALE  
DEPARTMENT OF PUBLIC SERVICES

DATE: 09-15-25

DRAWING NO.

**2-V**

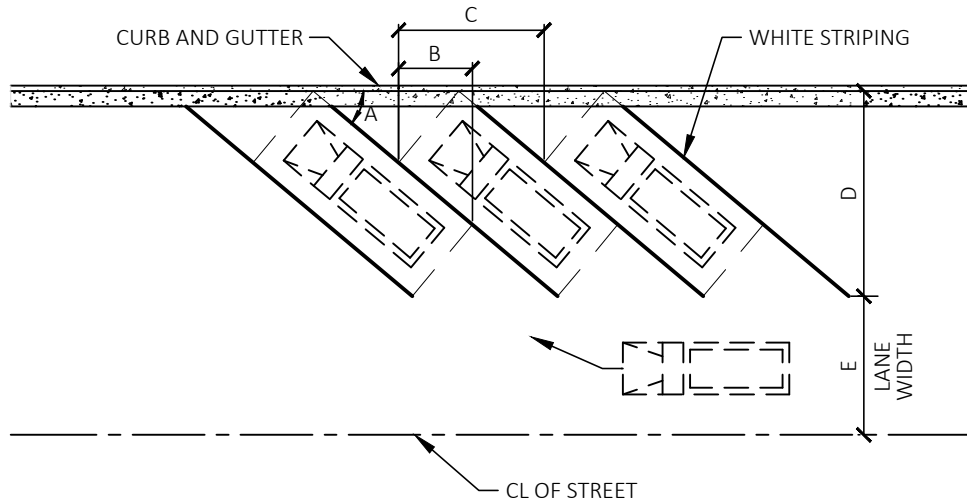
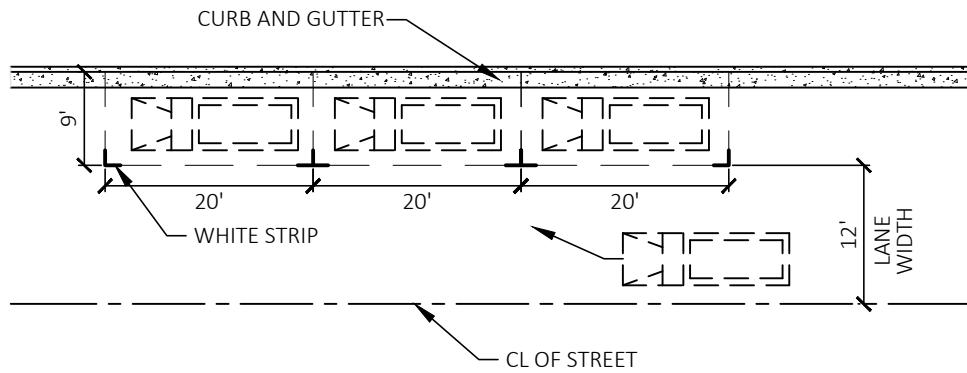

STANDARD PARKING STALL - 9' X 19'										
A	0°	20°	30°	40°	45°	50°	60°	70°	80°	90°
B	-	5.38'	2.95'	6.34'	7.07'	7.36'	9.50	6.50'	3.30'	-
C	-	26.25'	18.00'	14.00'	12.73'	11.75'	10.39	9.58'	9.14'	-
D	9.00'	14.95'	17.30'	19.10'	19.80'	20.34'	20.95'	20.93'	20.27'	19.00'
E	12.00'	11.00'	11.00'	12.00'	13.50'	12.50'	18.50'	19.50'	24.00'	25.00'

APPROVED BY CITY COUNCIL:  
RESOLUTION: 2025-094

*Rob Marler*

ROB MARLER, P.E. - CITY ENGINEER

# ON-STREET PARKING

CITY OF OAKDALE  
DEPARTMENT OF PUBLIC SERVICES

DATE: 09-15-25

DRAWING NO.

# 2-W

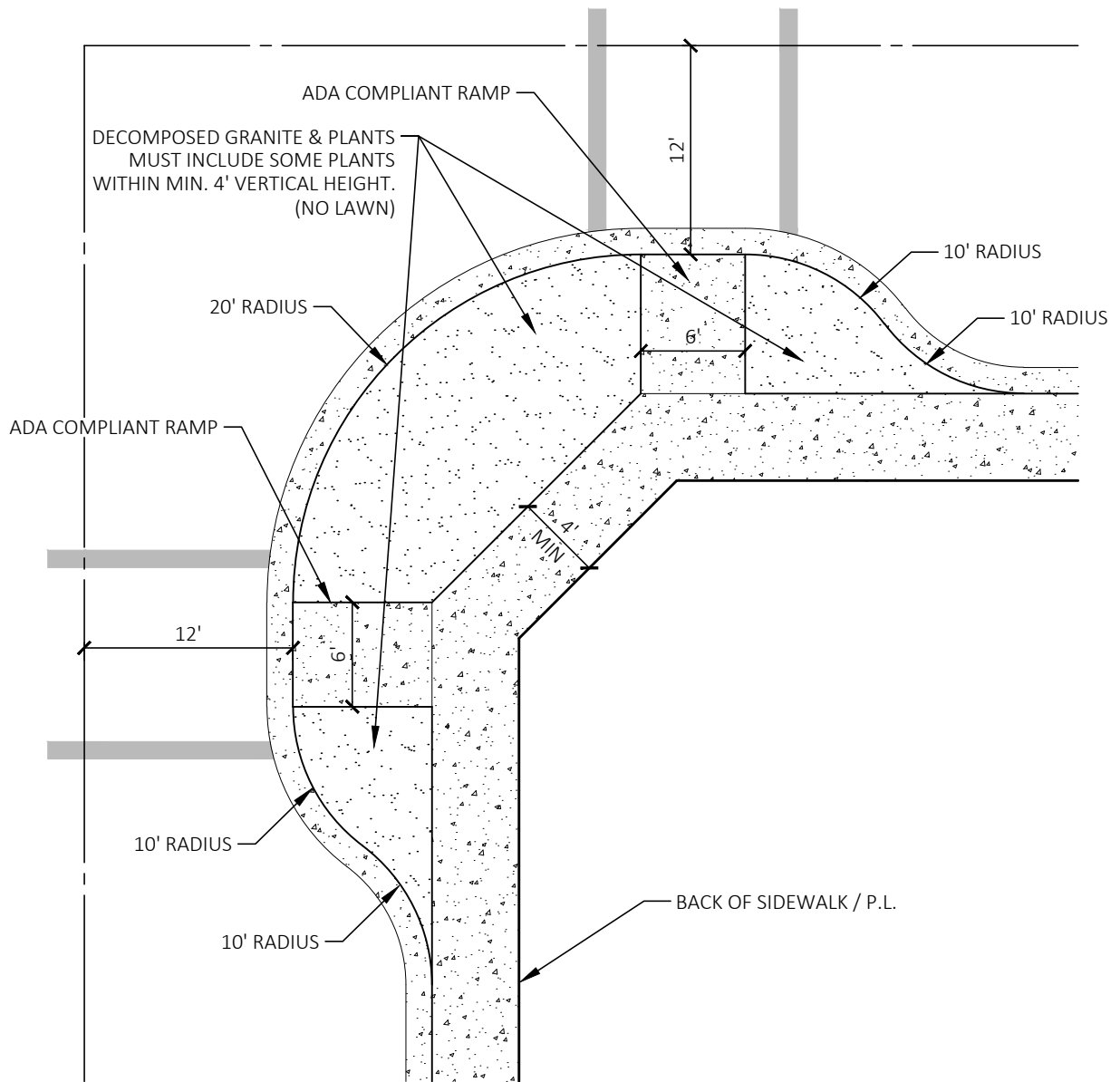

NOTES:

1. THE LOWER END OF THE RAMP SHALL BE FLUSH WITH THE GUTTER PAN.
2. TRANSITION GUTTER PAN CROSS SLOPE TO 5% MAX 4' OUTSIDE OF BOTTOM OF RAMP.
3. IF THE DISTANCE FROM THE BACK OF THE SIDEWALK TO THE BACK OF THE RAMP IS LESS THAN 4 FEET, THEN THE SLOPE OF THE FLARED SIDES SHALL NOT EXCEED 1:12.

APPROVED BY CITY COUNCIL:  
 RESOLUTION: 2025-094

*Rob Marler*

ROB MARLER, P.E. - CITY ENGINEER

# CURB EXTENSION

CITY OF OAKDALE  
 DEPARTMENT OF PUBLIC SERVICES

DATE: 09-15-25

DRAWING NO.

# 2-X

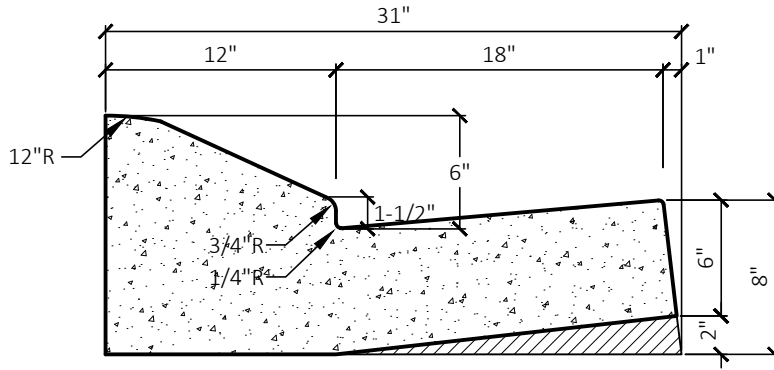

**6" DRIVE-OVER CURB & GUTTER**

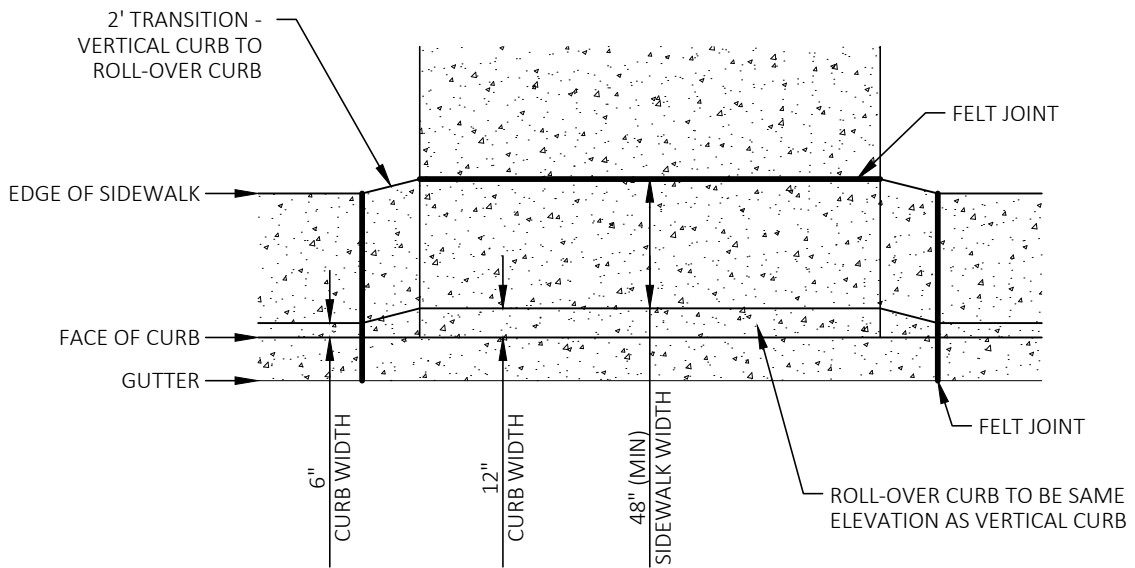

**VERTICAL TO ROLL-OVER DRIVEWAY ENTRANCE**

NOTES:

1. ALL SLOPES MUST BE IN A SINGLE PLANE.
2. WEAKENED PLANE JOINTS AT ALL GRADE BREAKS.
3. EXPANSION JOINTS AT RIGHT-OF-WAY WITH 1/2" FELT.
4. DRIVEWAYS SHALL BE PLACED A MINIMUM OF 10 FEET FROM CURB RETURNS.

APPROVED BY CITY COUNCIL:  
RESOLUTION: 2025-094

*Rob Marler*

ROB MARLER, P.E. - CITY ENGINEER

**VERTICAL TO ROLL-OVER  
DRIVEWAY APPROACH**

CITY OF OAKDALE  
DEPARTMENT OF PUBLIC SERVICES

DATE: 09-15-25

DRAWING NO.

**2-Y**

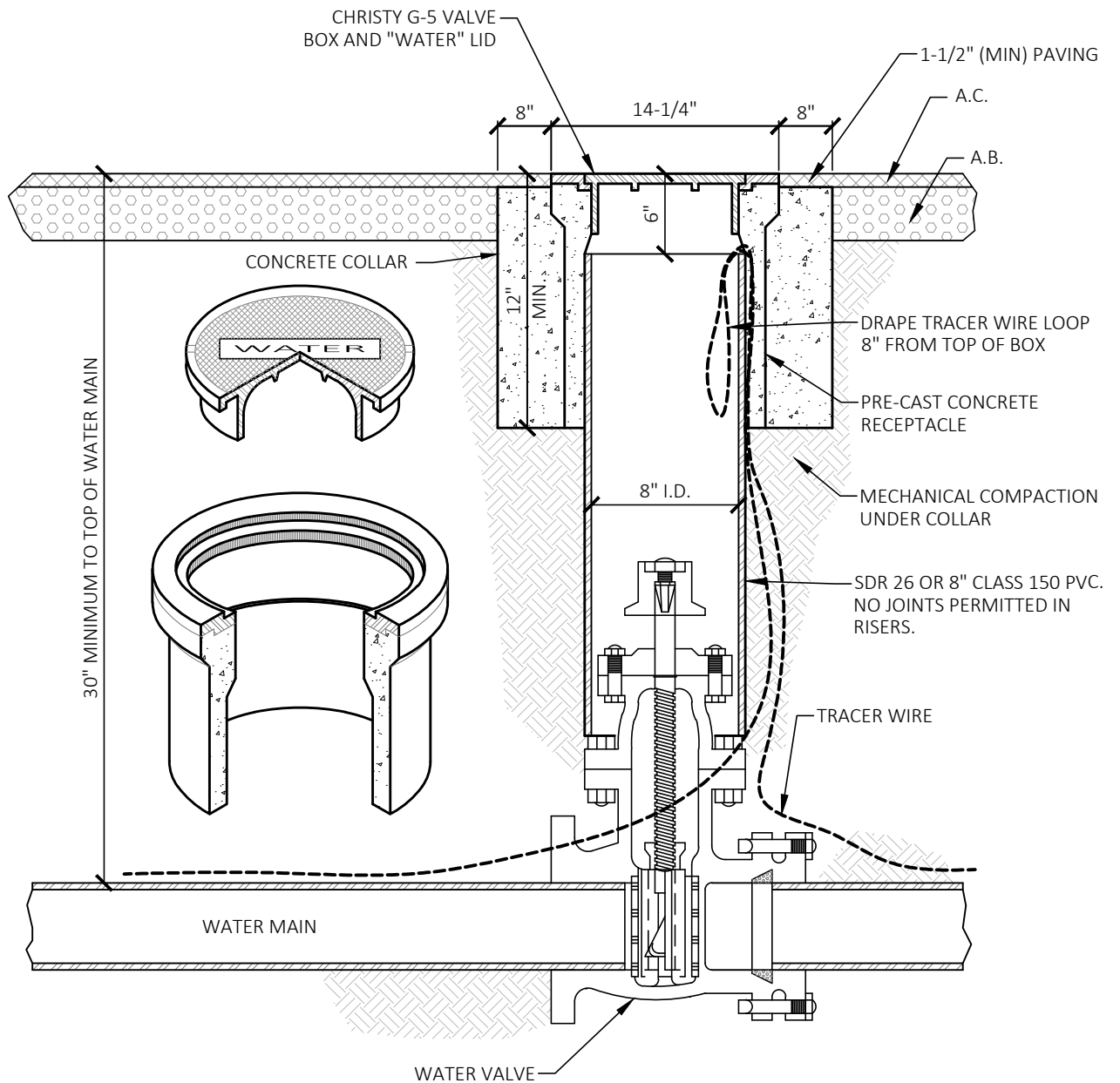

NOTES:

1. SEE SECTION 3 OF SPECIFICATIONS FOR APPROVED MATERIALS.
2. USE VALVE EXTENSION ON OPERATING NUTS DEEPER THAN 48". EXTENSION SHALL BE A PLACER WATERWORKS "RECYCLED WATER VALVE STEM EXTENSION" OR APPROVED EQUAL.

APPROVED BY CITY COUNCIL:  
RESOLUTION: 2025-094

*Rob Marler*

ROB MARLER, P.E. - CITY ENGINEER

# WATER VALVE BOX

CITY OF OAKDALE  
DEPARTMENT OF PUBLIC SERVICES

DATE: 09-15-25

DRAWING NO.

## 3-A

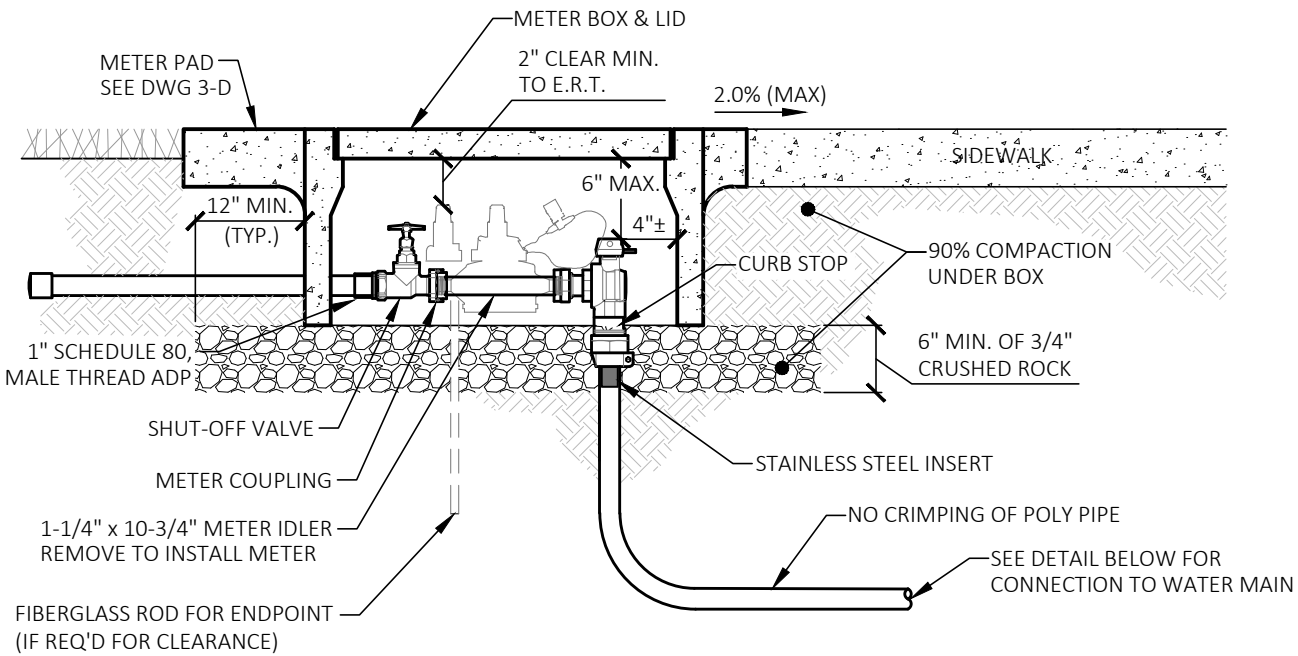

**SECTION**  
(SHOW W/IDLER)

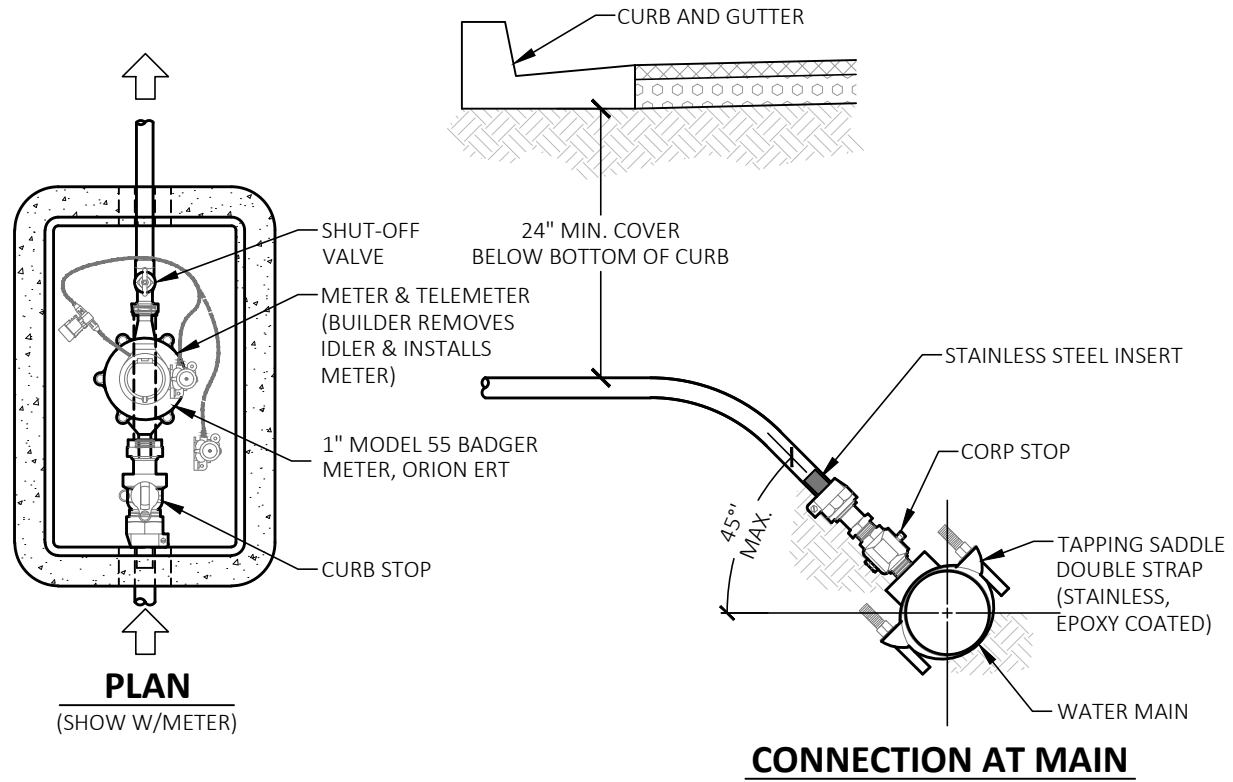

- NOTES:
1. SEE SECTION 3 OF SPECIFICATIONS FOR APPROVED MATERIALS.

APPROVED BY CITY COUNCIL:  
RESOLUTION: 2025-094

*Rob Marler*

ROB MARLER, P.E. - CITY ENGINEER

**1" WATER SERVICE  
(RESIDENTIAL)**

CITY OF OAKDALE  
DEPARTMENT OF PUBLIC SERVICES

DATE: 09-15-25

DRAWING NO.  
**3-B**

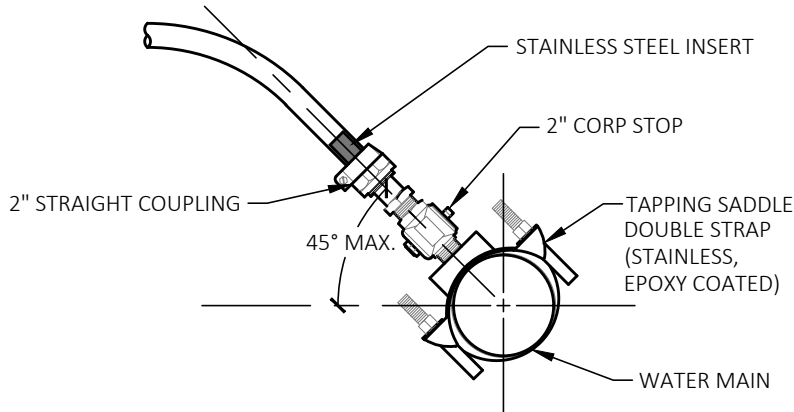
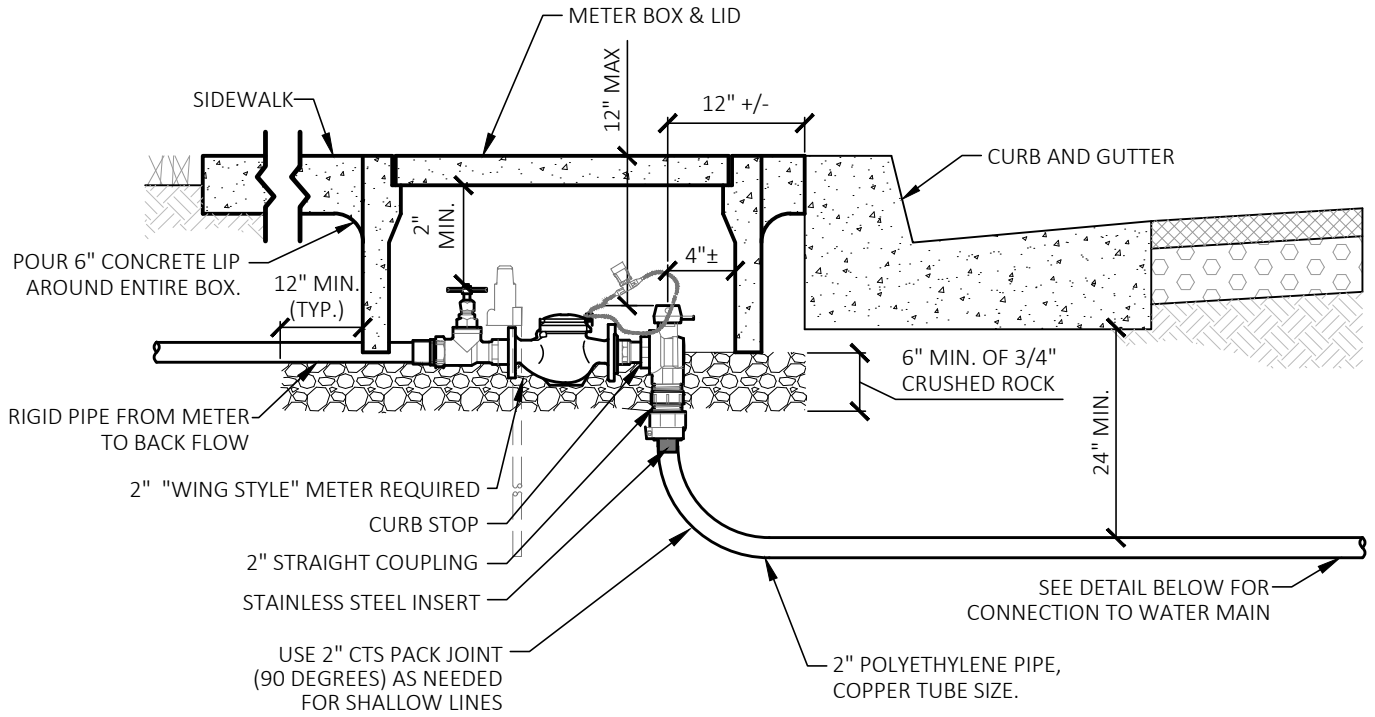

**CONNECTION AT MAIN**

NOTES:

1. SEE SECTION 3 OF SPECIFICATIONS FOR APPROVED MATERIALS.
2. IF THE SERVICE TRENCH IS IN EXISTING PAVING, THE PAVEMENT SHALL BE REPLACED AS PER SPECIFICATIONS FOR MAIN LINE TRENCH.
3. CURB, GUTTER AND SIDEWALK SHALL BE INSTALLED AFTER WATER SERVICE INSTALLATION UNLESS OTHERWISE NOTED.
4. CONTRACTOR SHALL BE RESPONSIBLE FOR DAMAGE TO EXISTING CURB, GUTTER AND SIDEWALK INCURRED DURING WATER SERVICE INSTALLATION OR SETTLING OF THE TRENCH.
5. SERVICE LINE SHALL BE A MINIMUM OF 24" BELOW BOTTOM OF CURB.
6. LANDSCAPE WATER SHALL USE A 2" TURBO METER WITH INTEGRAL STRAINER.
7. DOMESTIC WATER SHALL USE A 2" DISC METER.

APPROVED BY CITY COUNCIL:  
RESOLUTION: 2025-094

*Rob Marler*

ROB MARLER, P.E. - CITY ENGINEER

**2" WATER SERVICE  
(COMMERCIAL)**

CITY OF OAKDALE  
DEPARTMENT OF PUBLIC SERVICES

DATE: 09-15-25

DRAWING NO.

**3-C**

NOTES:

1. SEE SECTION 3 OF SPECIFICATIONS FOR APPROVED MATERIALS.
2. USE CHRISTY METER BOX AND FIBERLYTE LIDS.
3. ALL METER BOX CONCRETE PADS TO HAVE MINIMUM 1.5% SLOPE TOWARDS THE SIDEWALK.
4. PROVIDE 90% COMPACTION UNDER PAD.
5. PROVIDE RETAINING WALLS AROUND BOX PAD AS NEEDED TO MEET LOT GRADES.
6. SEE DRAWING NO. 3-O FOR PADS THAT INCLUDE A SAMPLING STATION (DRAWING NO. 3-M).

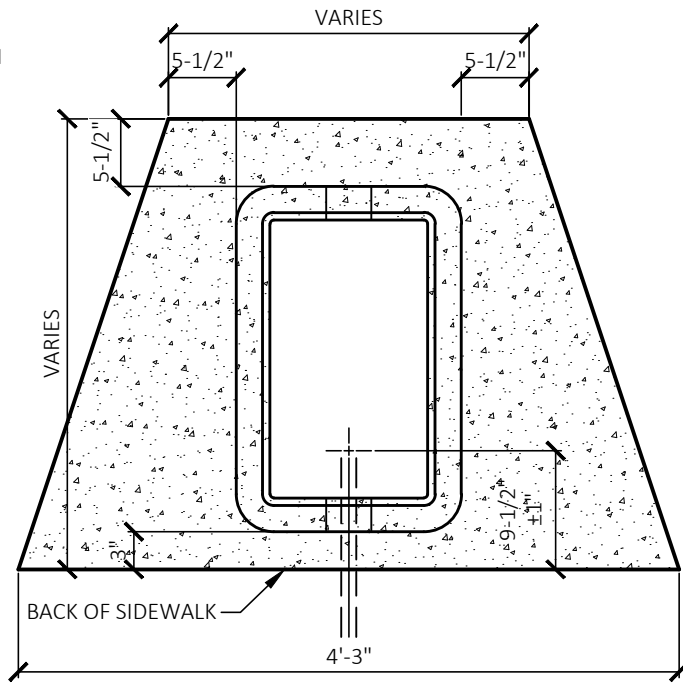

**SINGLE INSTALLATION**

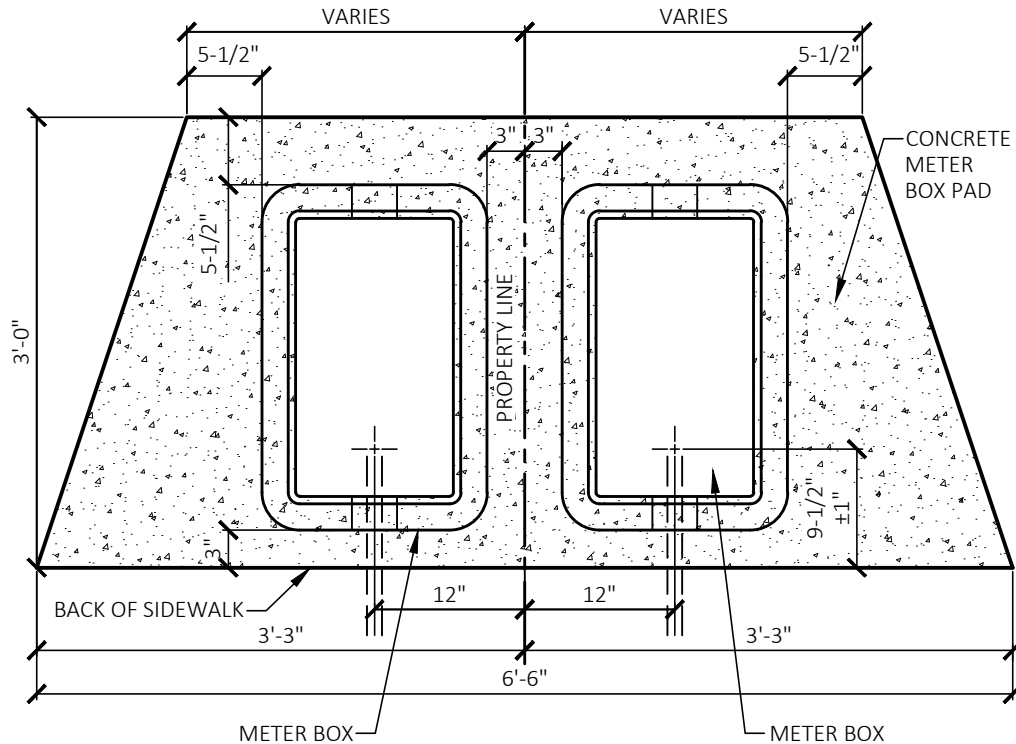

**DUAL INSTALLATION**

APPROVED BY CITY COUNCIL:  
RESOLUTION: 2025-094

*Rob Marler*

ROB MARLER, P.E. - CITY ENGINEER

**METER BOX PAD**

CITY OF OAKDALE  
DEPARTMENT OF PUBLIC SERVICES

DATE: 09-15-25

DRAWING NO.

**3-D**

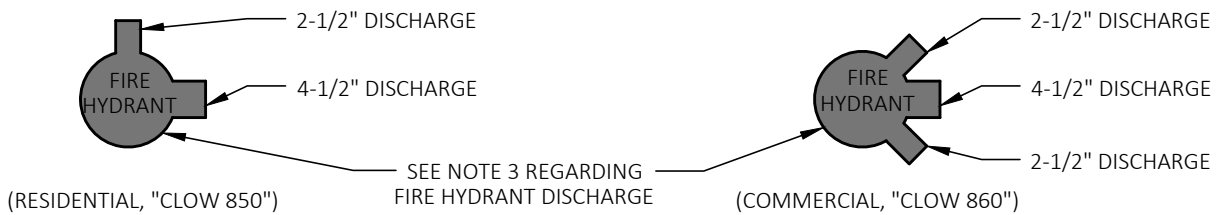
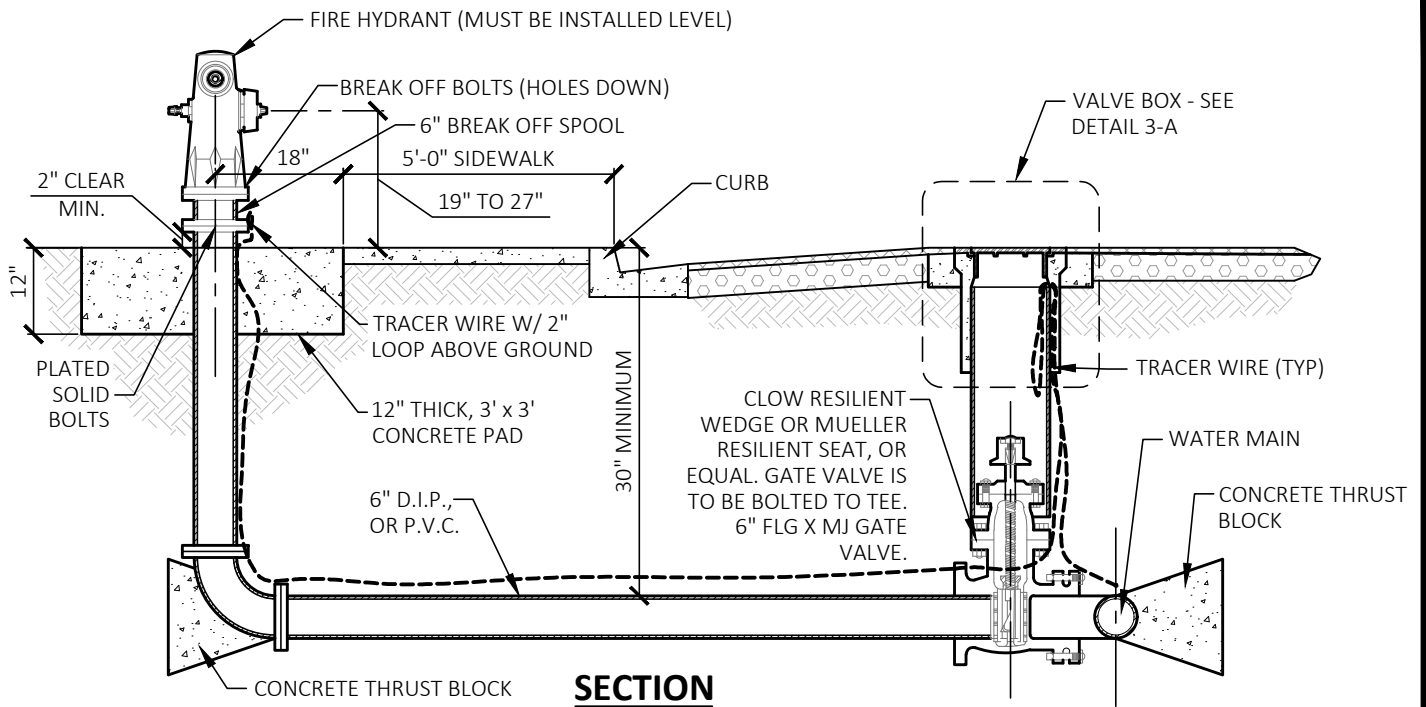

### FIRE HYDRANT DISCHARGE LOCATION

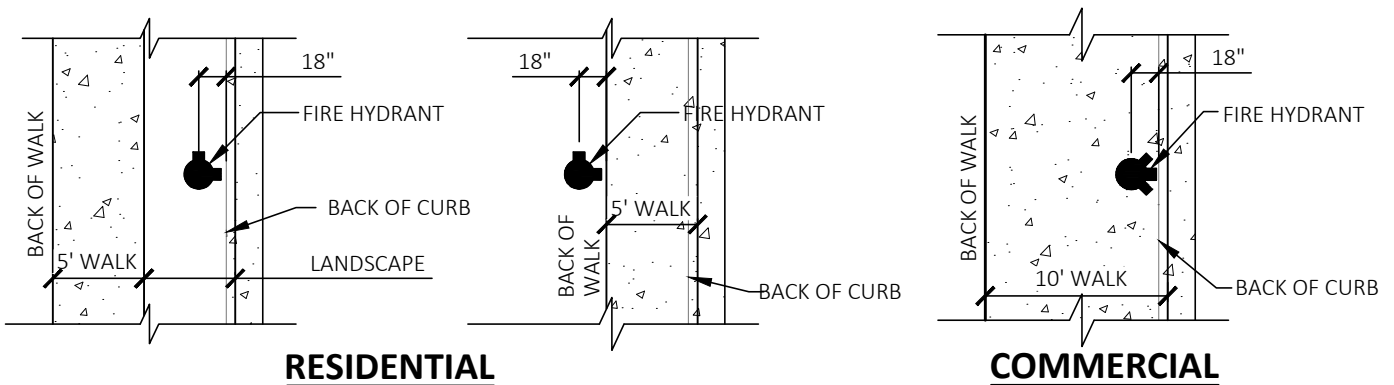

**NOTES:**

1. SEE SECTION 3 OF SPECIFICATIONS FOR APPROVED MATERIALS.
2. BREAK OFF BOLTS ARE TO BE HOLLOW BOLTS LOCATED THROUGH THE FIRE HYDRANT FLANGE WITH THE BOLTS POINTING DOWN.
3. ALL HYDRANTS SHALL BE POSITIONED SUCH THAT THE 4-1/2" DISCHARGE IS 0 DEGREES TO AND POINTING INTO THE STREET.

APPROVED BY CITY COUNCIL:  
RESOLUTION: 2025-094

*Rob Marler*

ROB MARLER, P.E. - CITY ENGINEER

## FIRE HYDRANT

CITY OF OAKDALE  
DEPARTMENT OF PUBLIC SERVICES

DATE: 09-15-25

DRAWING NO.

**3-E**

## THRUST BLOCK DIMENSIONS

FITTINGS	SIDE "A"	SIDE "B"
6" & 8" LINE		
22-1/2 °	2'-0"	2'-0"
45°	3'-0"	3'-0"
90°	4'-0"	3'-0"
TEE	3'-0"	3'-0"
DEAD END	3'-0"	3'-0"

FITTINGS	SIDE "A"	SIDE "B"
10" LINE		
22-1/2 °	3'-0"	2'-0"
45°	4'-0"	4'-0"
90°	5'-0"	4'-0"
TEE	4'-0"	3'-6"
DEAD END	4'-0"	3'-6"

FITTINGS	SIDE "A"	SIDE "B"
12" LINE		
22-1/2 °	3'-6"	3'-6"
45°	5'-0"	5'-0"
90°	6'-0"	7'-4"
TEE	5'-7"	5'-7"
DEAD END	4'-10"	4'-10"

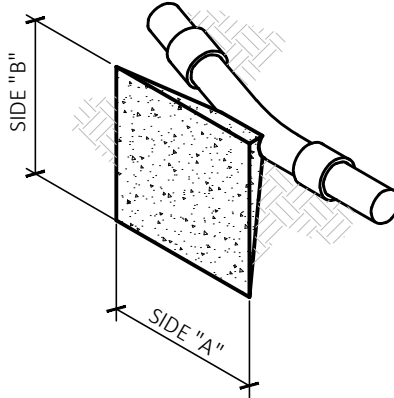

**ANGLE**

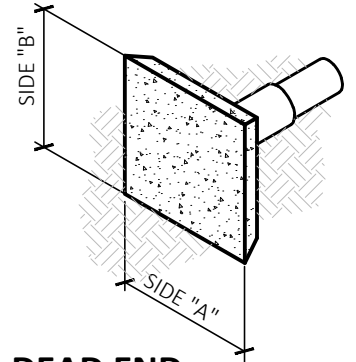

**DEAD END**

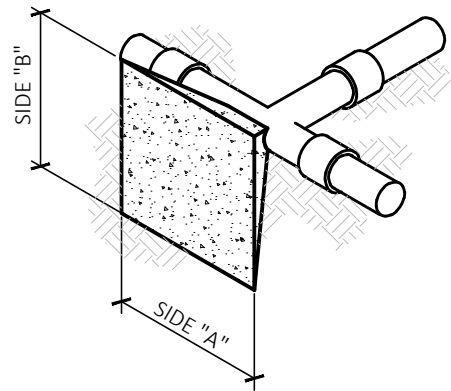

**TEE**

## MINIMUM THRUST BLOCK AREAS

(IN SQUARE FEET)

PIPE SIZE	TEE	90 ° BEND	45 ° BEND	22-1/2 ° BEND	DEAD END
4"	1.5 SF	2 SF	1.5 SF	1 SF	1.5 SF
6"	3 SF	4.5 SF	2.5 SF	1.5 SF	3 SF
8"	5 SF	7 SF	4 SF	2 SF	5 SF
10"	8.5 SF	11.5 SF	6.5 SF	3.5 SF	8.5 SF
12"	11.5 SF	16.5 SF	9 SF	4.5 SF	11.5 SF

NOTES:

- SEE SECTION 3 OF SPECIFICATIONS FOR APPROVED MATERIALS.
- AREAS ARE FOR 150 POUNDS PER SQUARE INCH WATER PRESSURE AND SANDY TYPE SOILS. AREAS SHALL BE DOUBLED FOR CLAY TYPE SOILS.
- BLOCKING SHALL BE MADE OF CLASS "B" CONCRETE AND SHALL BE PLACED BETWEEN UNDISTURBED GROUND AND THE FITTING TO BE ANCHORED. THE BLOCKING SHALL BE PLACED SO THAT THE JOINTS OF THE PIPE AND FITTINGS WILL BE ACCESSIBLE FOR REPAIR.
- THRUST BLOCKS SHALL BE CONSTRUCTED AT PIPE DIAMETER CHANGES AND AT OTHER FITTINGS NOT LISTED, AND SHALL BE PLACED AS DIRECTED BY THE ENGINEER.
- CONCRETE SHALL BE A MINIMUM OF 12" THICK.

APPROVED BY CITY COUNCIL:  
RESOLUTION: 2025-094

*Rob Marler*

ROB MARLER, P.E. - CITY ENGINEER

## THRUST BLOCK

CITY OF OAKDALE  
DEPARTMENT OF PUBLIC SERVICES

DATE: 09-15-25

DRAWING NO.

**3-F**

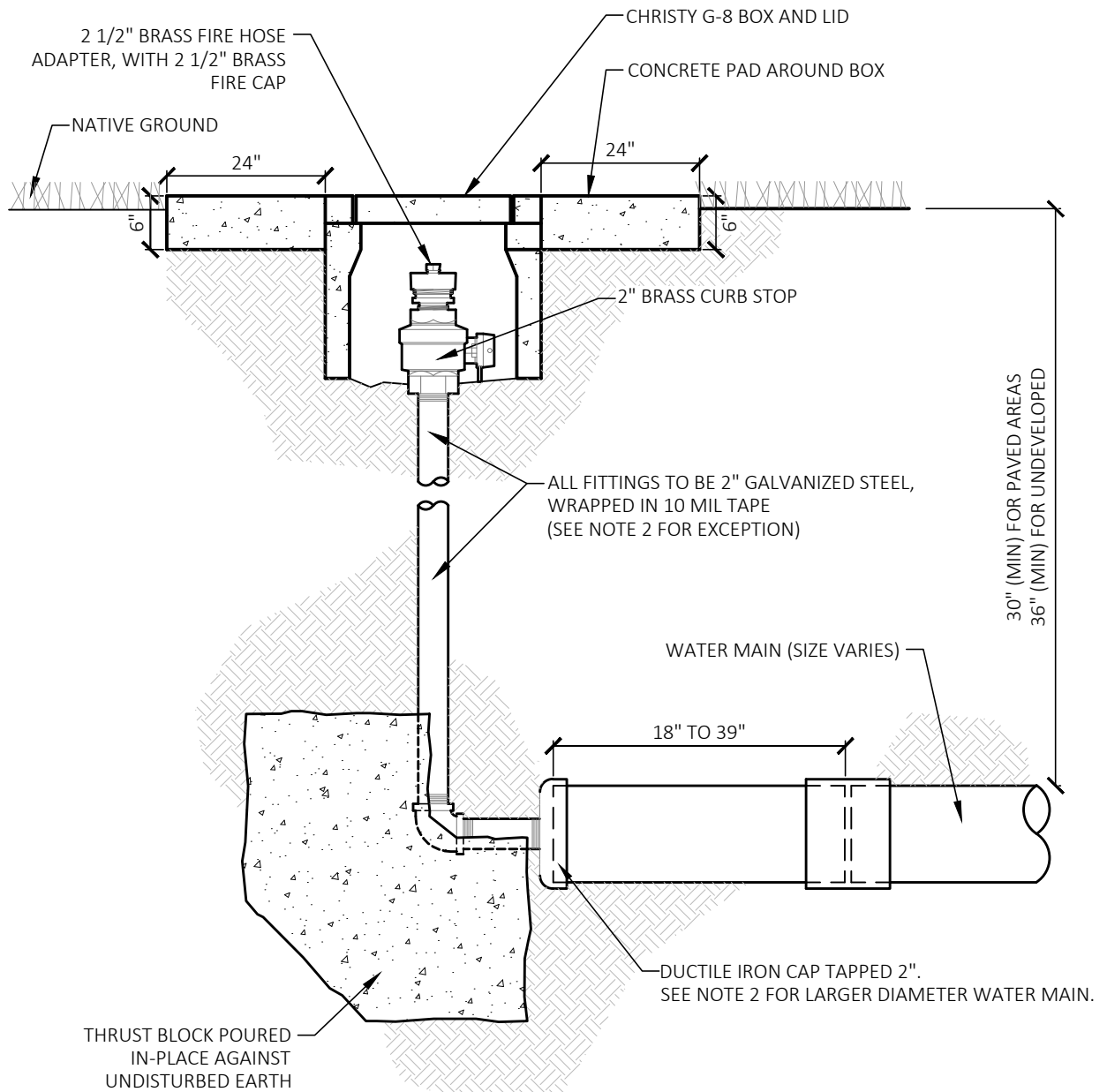

NOTES:

1. SEE SECTION 3 OF SPECIFICATIONS FOR APPROVED MATERIALS.
2. WATER MAINS THAT ARE 10" OR LARGER SHALL USE AN ECCENTRIC IRON CAP WITH 4" BLOWOFF.

APPROVED BY CITY COUNCIL:  
RESOLUTION: 2025-094

*Rob Marler*

ROB MARLER, P.E. - CITY ENGINEER

# WATER BLOW-OFF

CITY OF OAKDALE  
DEPARTMENT OF PUBLIC SERVICES

DATE: 09-15-25

DRAWING NO.

# 3-G

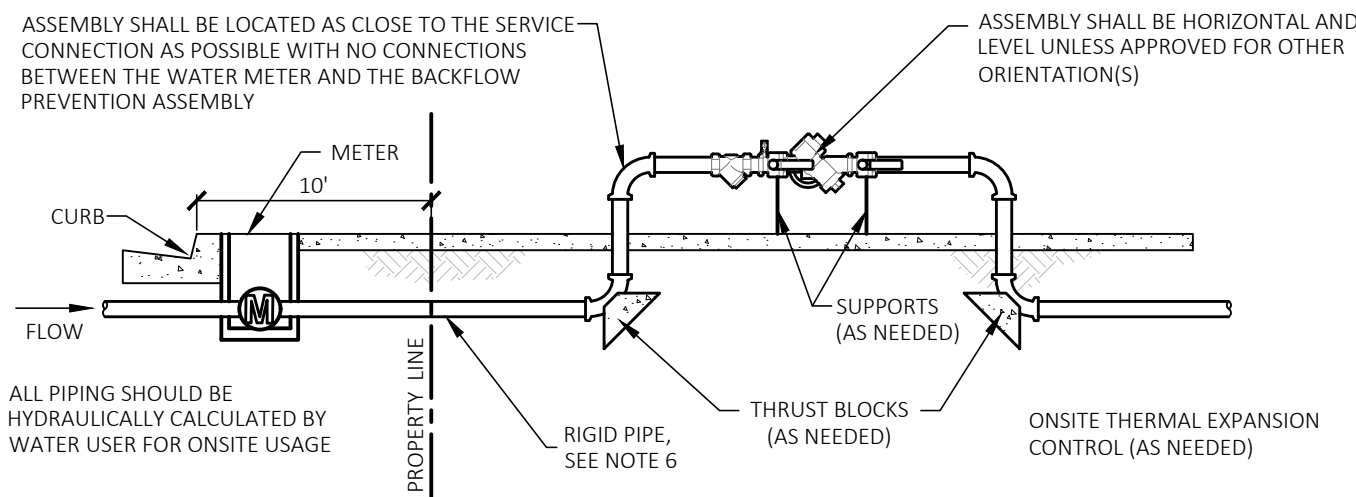

**SERVICE CONNECTION INSTALLATION GUIDELINES**

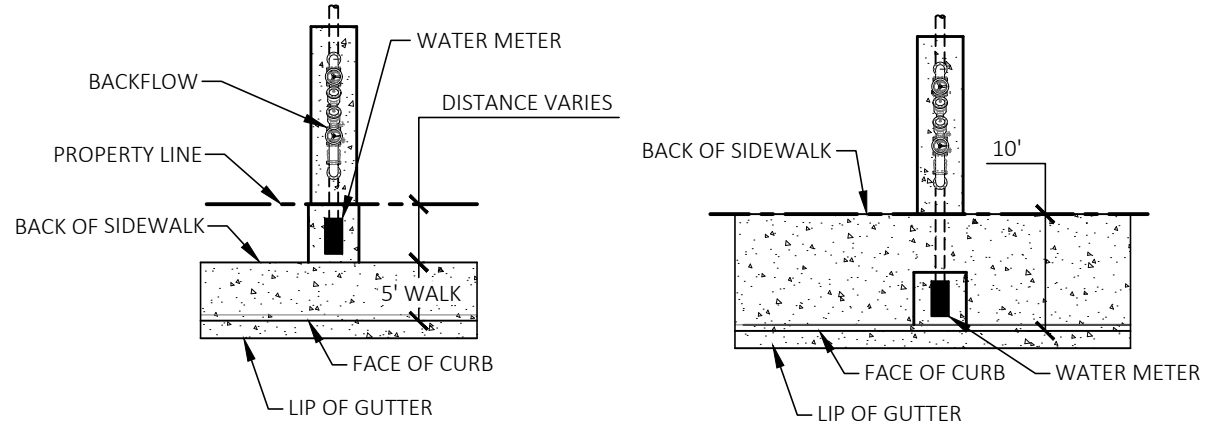

**SERVICE CONNECTION EXAMPLE LOCATIONS**

NOTES:

1. SEE SECTION 3 OF SPECIFICATIONS FOR APPROVED MATERIALS.
2. BACKFLOW PREVENTION ASSEMBLIES ARE TO BE USED WITHIN THEIR RATED OPERATING CONDITIONS.
3. PRESSURE: BACKFLOW PREVENTION ASSEMBLIES TYPICALLY HAVE MAXIMUM WORKING WATER PRESSURES (MWWP) OF 150 PSI (1034 KPA) OR 175 PSI. ASSEMBLIES ARE DESIGNED TO OPERATE CONTINUOUSLY AT THIS PRESSURE, WHICH IS IDENTIFIED ON THE ASSEMBLY.
4. ALL INSTALLATIONS OF BACKFLOW PREVENTION ASSEMBLIES MUST BE IN COMPLIANCE WITH STATE AND LOCAL PLUMBING CODES. CONTACT LOCAL ADMINISTRATIVE AUTHORITY FOR DETAILED REQUIREMENTS.
5. ALL ABOVE GROUND PIPING AND FITTINGS SHALL BE COPPER, NO-LEAD BRONZE, NO-LEAD GALVANIZED, OR DUCTILE IRON.
6. ALL PLUMBING FROM METER TO BACKFLOW SHALL BE RIDGED COPPER OR NO-LEAD BRONZE PIPING (CONSULT CITY STAFF).

APPROVED BY CITY COUNCIL: RESOLUTION: 2025-094	<h1 style="margin: 0;">COMMERCIAL BACKFLOW CONFIGURATION</h1>	DATE: 09-15-25
	CITY OF OAKDALE DEPARTMENT OF PUBLIC SERVICES	DRAWING NO. <h2 style="margin: 0;">3-H</h2>
ROB MARLER, P.E. - CITY ENGINEER		

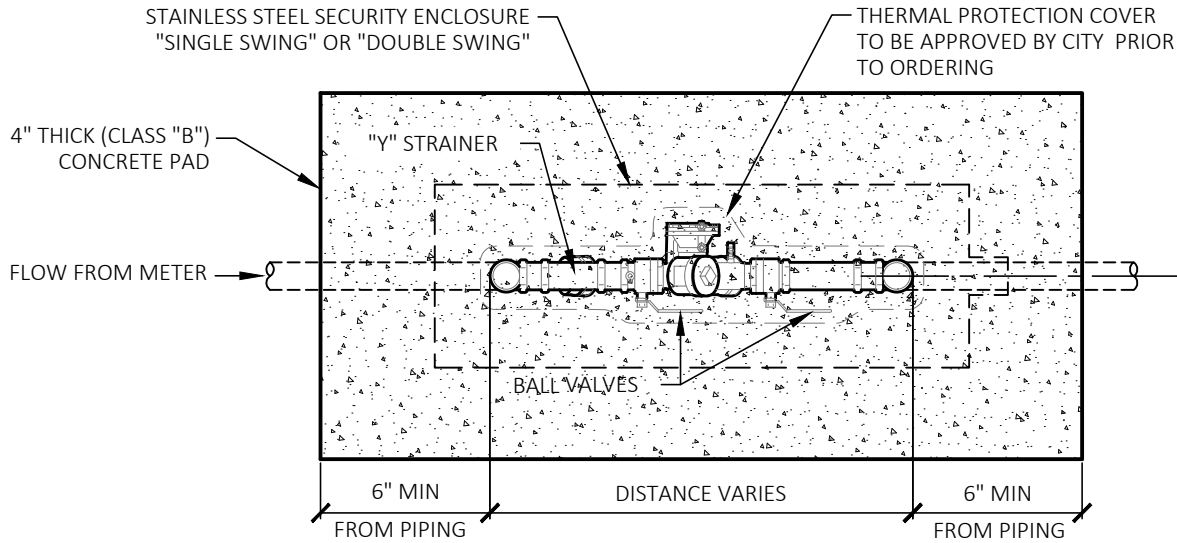

**PLAN**

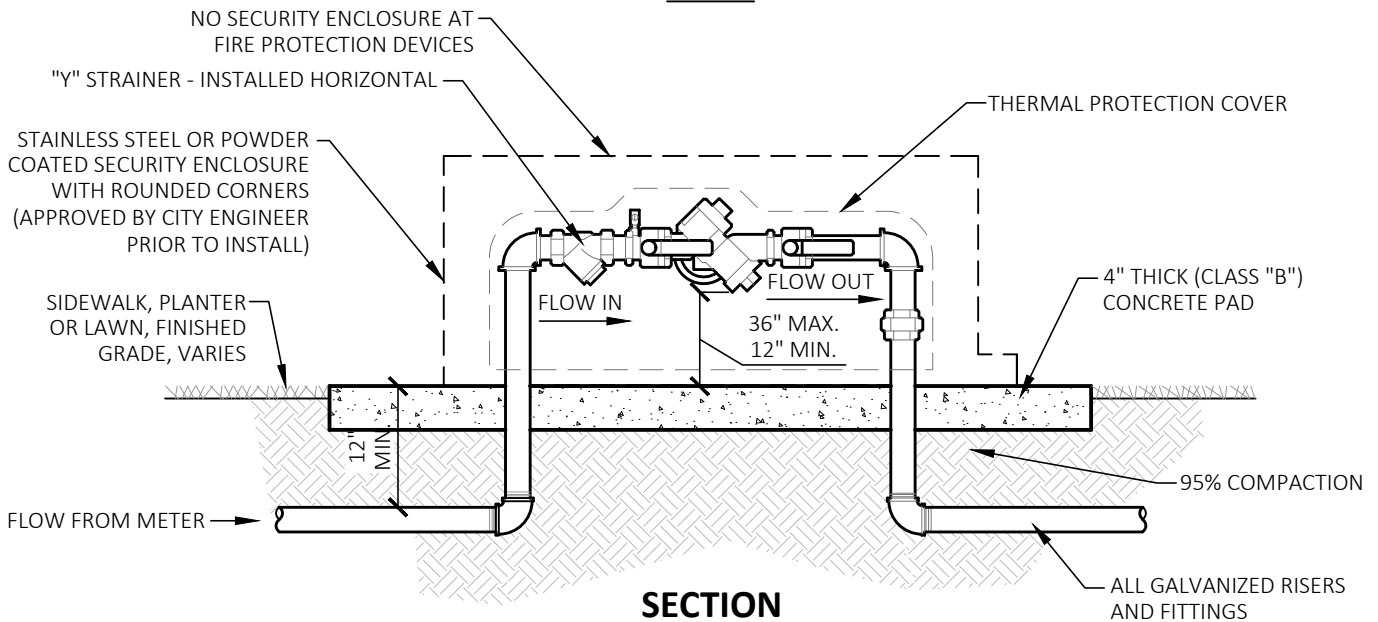

**SECTION**

NOTES:

1. SEE SECTION 3 OF SPECIFICATIONS FOR APPROVED MATERIALS.
2. CONTACT WATER DEPARTMENT FOR ALL INSPECTIONS AT 209-845-3613.
3. INSTALL 12" AIR GAP MINIMUM FROM BOTTOM OF RELIEF VALVE (CONSULT TITLE 17 & 22 CAL. REGULATIONS FOR DRINKING WATER).
4. PLUMBING INSTALLED BY LICENSED CONTRACTOR.
5. BACKFLOW DEVICE SIZE IS TO BE SAME SIZE AS EXISTING SERVICE LINE.
6. CONTRACTOR / DEVELOPER TO PROVIDE IN-LINE METER IF REQUIRED BY CITY ENGINEER.
7. ALL ABOVE GROUND FITTINGS & DEVICES SHALL BE COPPER, NO-LEAD BRONZE, OR NO-LEAD GALVANIZED PIPE.
8. BACKFLOW DEVICE SHALL BE A REDUCED PRESSURE (RP) ASSEMBLY.
9. ALL PIPING FROM BACK OF METER THROUGH DEVICE AND ABOVE GROUND SHALL BE GALVANIZED.

APPROVED BY CITY COUNCIL:  
RESOLUTION: 2025-094

*Rob Marler*

ROB MARLER, P.E. - CITY ENGINEER

**SMALL BACKFLOW (RP)**

CITY OF OAKDALE  
DEPARTMENT OF PUBLIC SERVICES

DATE: 09-15-25

DRAWING NO.

**3-1**

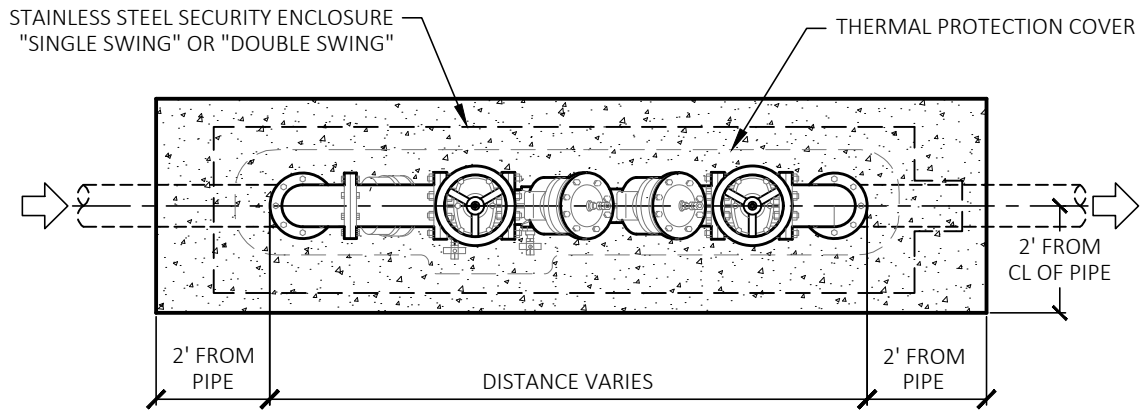

**PLAN**

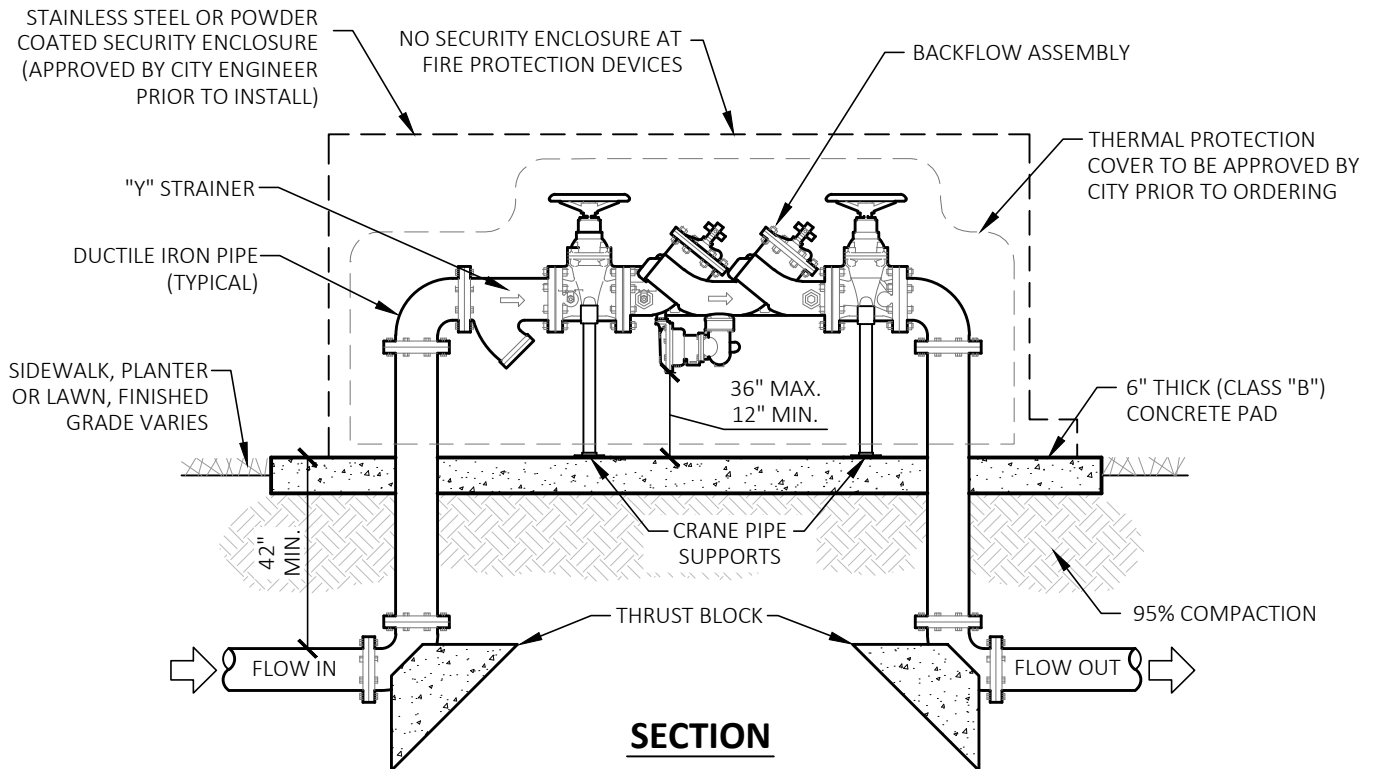

**SECTION**

NOTES:

1. SEE SECTION 3 OF SPECIFICATIONS FOR APPROVED MATERIALS.
2. CONTACT WATER DEPARTMENT FOR ALL INSPECTIONS AT 209-845-3613.
3. INSTALL 12" AIR GAP MINIMUM FROM BOTTOM OF RELIEF VALVE (CONSULT TITLE 17 & 22 CAL. REGULATIONS FOR DRINKING WATER).
4. ALL CONNECTIONS ON ASSEMBLY TO BE FLANGED.
5. BACKFLOW DEVICE SIZE IS TO BE SAME SIZE AS EXISTING MAIN OR SERVICE CONNECTION.
6. CONTRACTOR / DEVELOPER TO PROVIDE IN-LINE METER IF REQUIRED BY CITY ENGINEER.
7. ALL ABOVE GROUND PIPING AND FITTINGS SHALL BE COPPER, NO-LEAD BRONZE, OR DUCTILE IRON.

APPROVED BY CITY COUNCIL:  
RESOLUTION: 2025-094

*Rob Marler*

ROB MARLER, P.E. - CITY ENGINEER

**LARGE BACKFLOW (RP)**

(FOR 3" TO 10" SERVICES)

CITY OF OAKDALE  
DEPARTMENT OF PUBLIC SERVICES

DATE: 09-15-25

DRAWING NO.

**3-J**

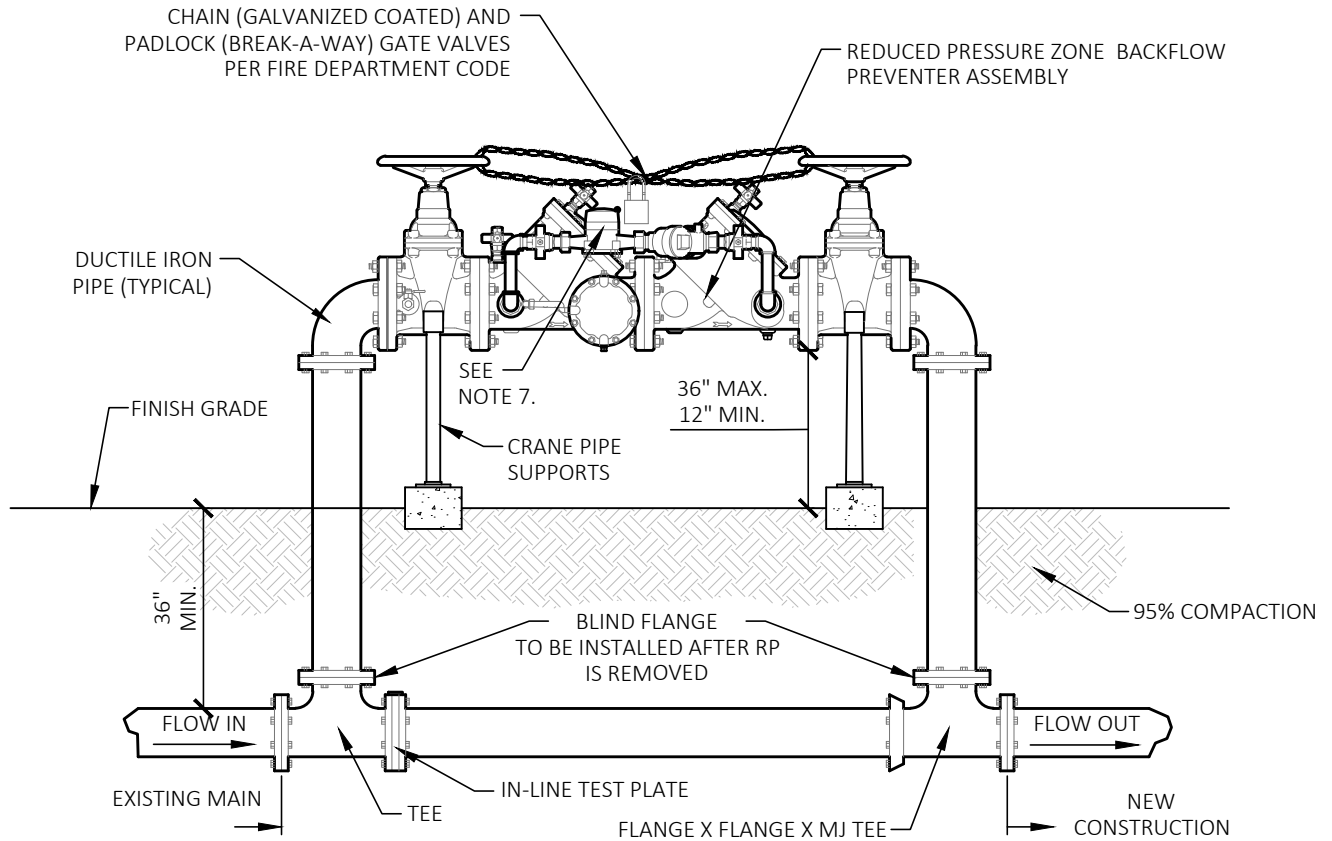

NOTES:

1. SEE SECTION 3 OF SPECIFICATIONS FOR APPROVED MATERIALS.
2. CONTACT WATER DEPARTMENT FOR ALL INSPECTIONS AT 209-845-3613.
3. INSTALL 12" AIR GAP MINIMUM FROM BOTTOM OF RELIEF VALVE (CONSULT TITLE 17 & 22 CAL. REGULATIONS FOR DRINKING WATER).
4. ALL CONNECTIONS ON ASSEMBLY TO BE FLANGED.
5. BACKFLOW DEVICE SIZE IS TO BE SAME SIZE AS EXISTING MAIN.
6. CONTRACTOR / DEVELOPER TO PROVIDE IN-LINE METER IF REQUIRED BY CITY ENGINEER.
7. ALL ABOVE GROUND PIPING AND FITTINGS SHALL BE DUCTILE IRON, OR NO-LEAD GALVANIZED (2" OR SMALLER).
8. TEMPORARY BACKFLOW DEVICE SHALL BE REDUCED PRESSURE (RP) ASSEMBLY.

APPROVED BY CITY COUNCIL:  
RESOLUTION: 2025-094

*Rob Marler*

ROB MARLER, P.E. - CITY ENGINEER

## TEMPORARY BACKFLOW (RP)

CITY OF OAKDALE  
DEPARTMENT OF PUBLIC SERVICES

DATE: 09-15-25

DRAWING NO.

# 3-K

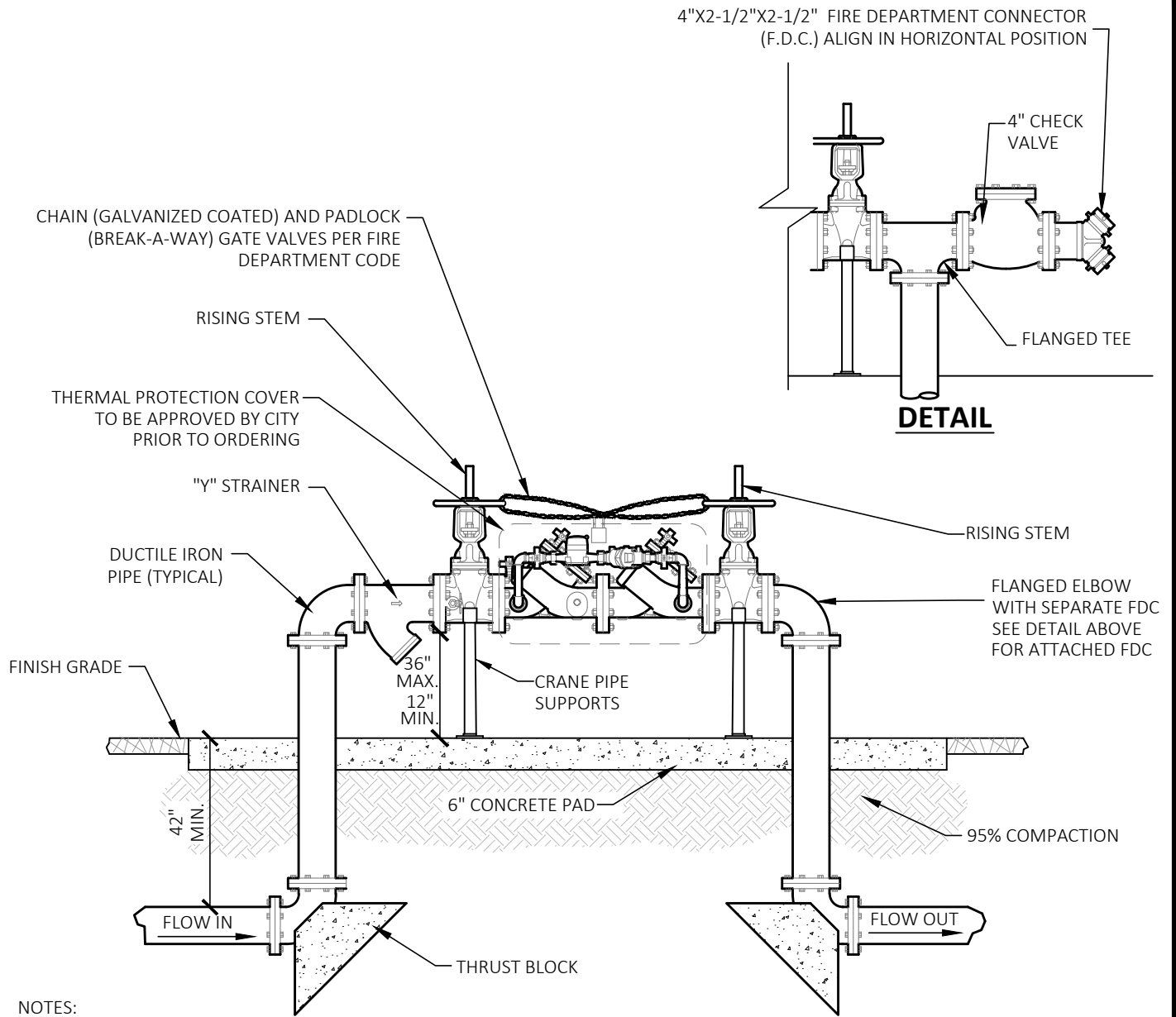

NOTES:

1. SEE SECTION 3 OF SPECIFICATIONS FOR APPROVED MATERIALS.
2. IF FIRE SYSTEM INCLUDES BOOSTER PUMP OR INJECTION SYSTEM, THEN BACKFLOW MUST BE RP DEVICE (SEE DETAIL 3-K).
3. CONTACT WATER DEPARTMENT FOR ALL INSPECTIONS AT 209-845-3600.
4. INSTALL 12" MINIMUM FROM BASE OF UNIT (CONSULT LOCAL CODE).
5. ALL CONNECTIONS ON ASSEMBLY TO BE FLANGED.
6. BACKFLOW DEVICE SIZE IS TO BE SAME SIZE AS EXISTING MAIN.
7. CONTRACTOR / DEVELOPER TO PROVIDE IN-LINE METER IF REQUIRED BY CITY ENGINEER.
8. ALL ABOVE GROUND PIPING AND FITTINGS SHALL BE NO-LEAD BRONZE, OR DUCTILE IRON.
9. IF A BOOSTER PUMP STATION OR CHEMICALS ARE PRESENT, A REDUCED PRESSURE (RP) ASSEMBLY SHALL BE INSTALLED.

APPROVED BY CITY COUNCIL:  
RESOLUTION: 2025-094

*Rob Marler*

ROB MARLER, P.E. - CITY ENGINEER

**DOUBLE DETECTOR CHECK**  
(FOR FIRE LINES)

CITY OF OAKDALE  
DEPARTMENT OF PUBLIC SERVICES

DATE: 09-15-25

DRAWING NO.

**3-L**

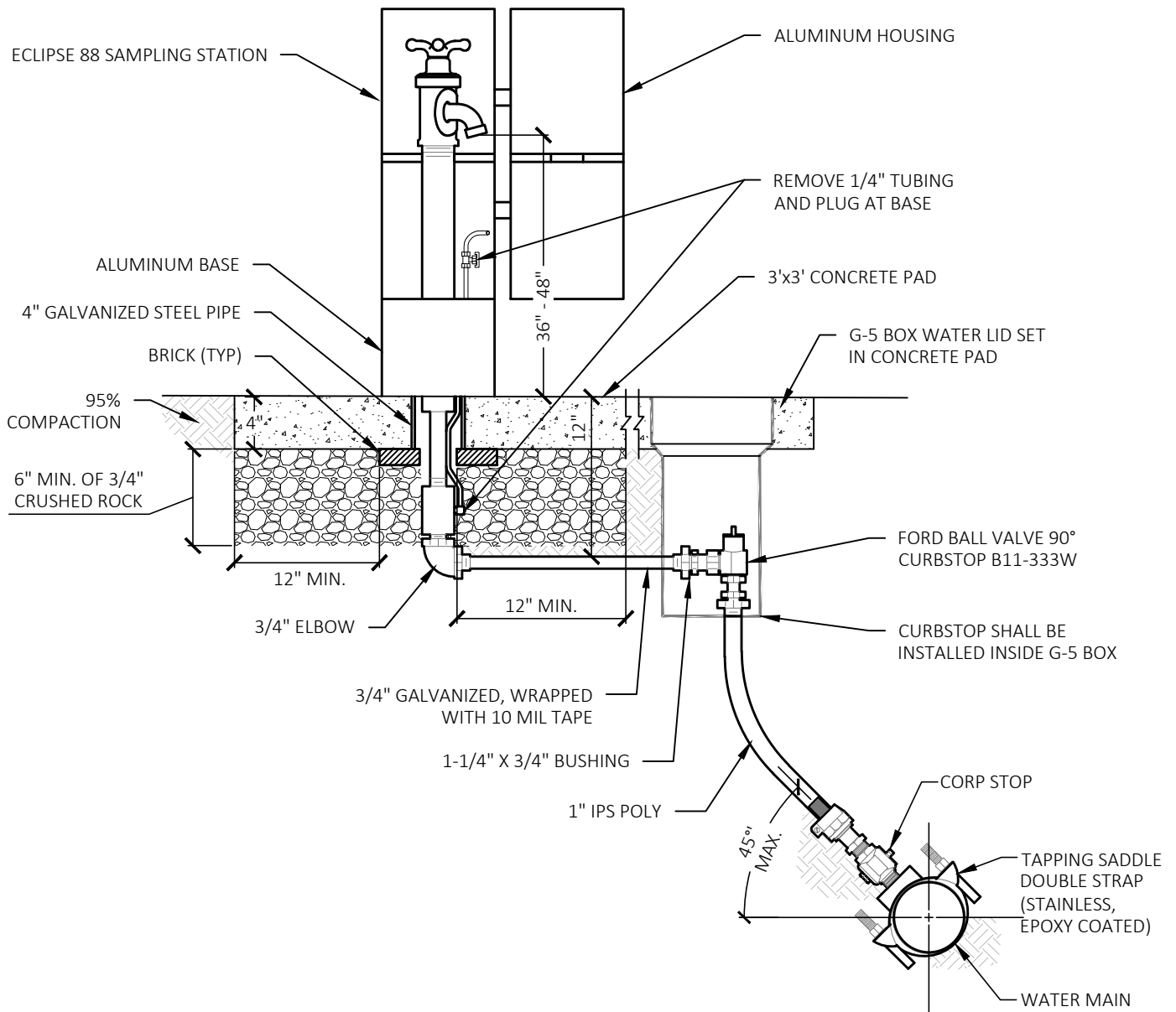

NOTES:

1. ALL STATIONS SHALL BE ENCLOSED IN AN "ECLIPSE 88 SAMPLING STATION (WINTER EDITION)". STATIONS SHALL BE FULLY ENCLOSED AND LOCKABLE.
2. ALL ABOVE GROUND PIPING SHALL BE BRASS OR GALVANIZED.
3. ALL MATERIALS SHALL COMPLY WITH CALIFORNIA NO LEAD REQUIREMENTS.
4. SEE DRAWING NO. 3-O FOR SAMPLING STATIONS INSTALLED WITH METER BOX PADS.

APPROVED BY CITY COUNCIL:  
RESOLUTION: 2025-094

*Rob Marler*

ROB MARLER, P.E. - CITY ENGINEER

# SAMPLING STATION

CITY OF OAKDALE  
DEPARTMENT OF PUBLIC SERVICES

DATE: 09-15-25

DRAWING NO.

## 3-M

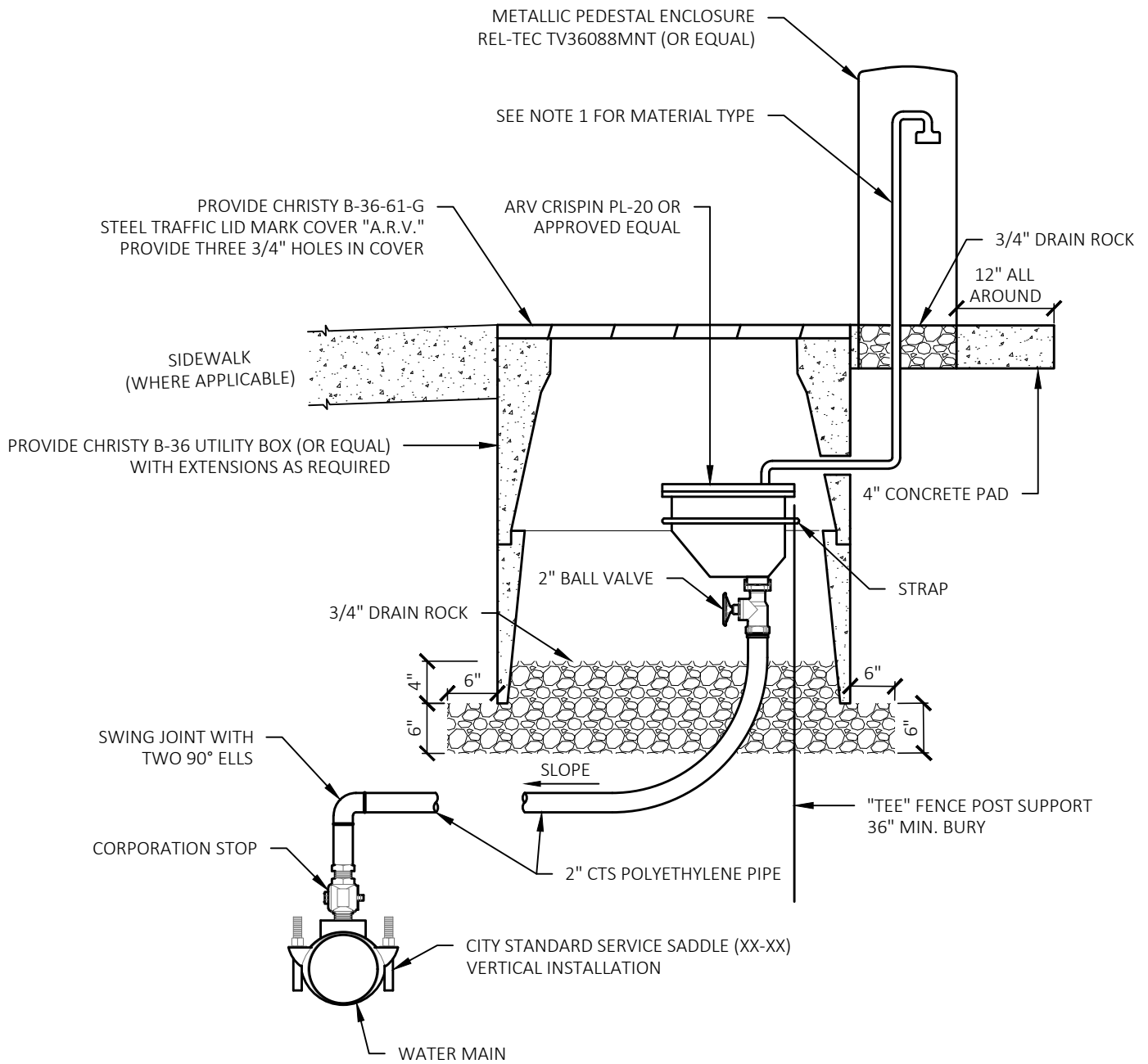

NOTES:

1. SADDLES, GATE VALVES, FITTINGS, ETC., SHALL BE BRONZE & SHALL MATCH COMBINATION AIR RELEASE VALVE SIZE.
2. ALL MATERIAL SHALL COMPLY WITH CALIFORNIA NO LEAD REQUIRMENTS.

APPROVED BY CITY COUNCIL:  
RESOLUTION: 2025-094

*Rob Marler*

ROB MARLER, P.E. - CITY ENGINEER

# AIR RELIEF VALVE

CITY OF OAKDALE  
DEPARTMENT OF PUBLIC SERVICES

DATE: 09-15-25

DRAWING NO.

# 3-N

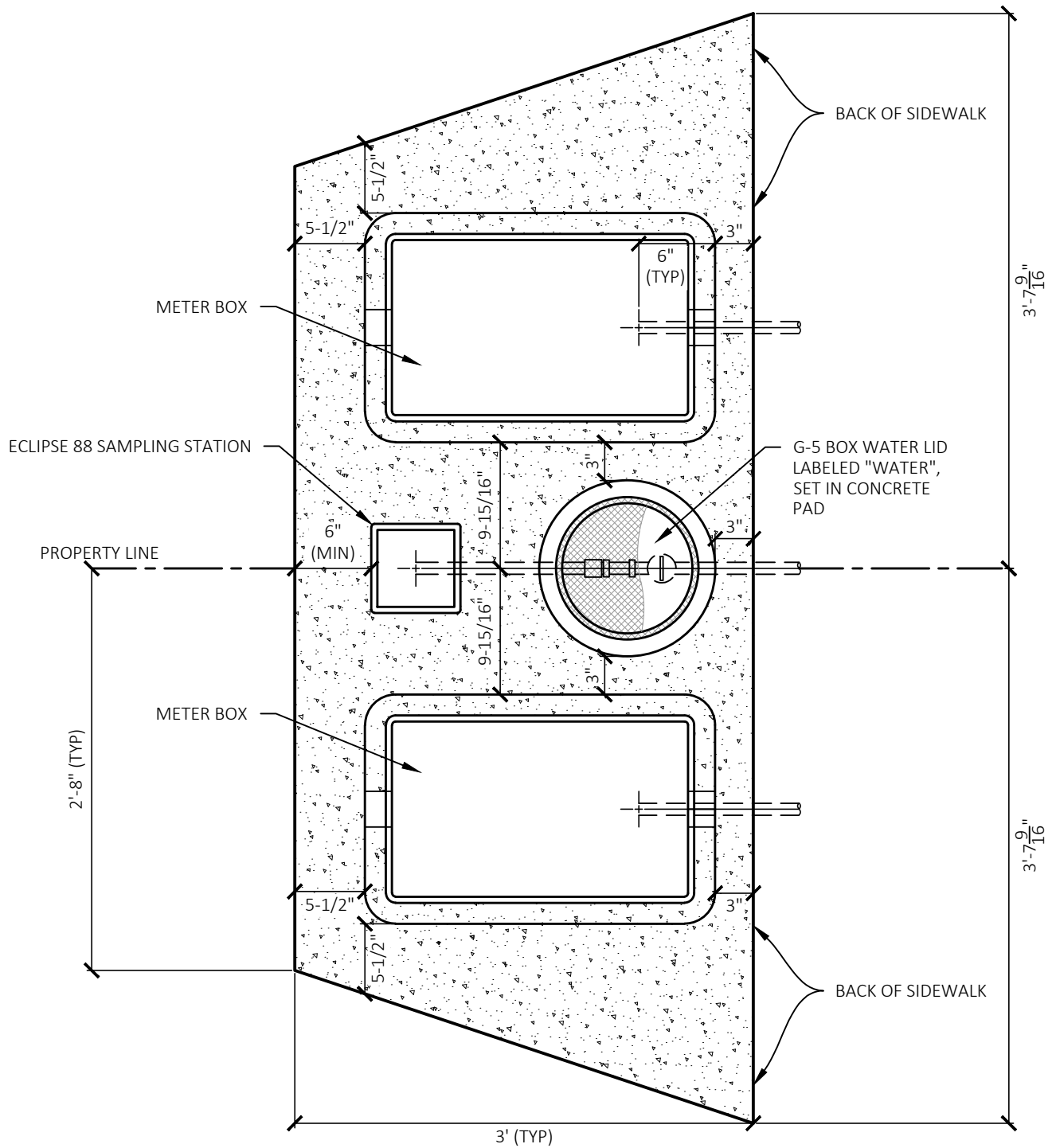

NOTES:

1. SEE DRAWING NO. 3-D "METER BOX PAD" AND 3-M "SAMPLING STATION" FOR ADDITIONAL NOTES & DETAILS.

APPROVED BY CITY COUNCIL:  
RESOLUTION: 2025-094

*Rob Marler*

ROB MARLER, P.E. - CITY ENGINEER

# METER BOX PAD & SAMPLING STATION

CITY OF OAKDALE  
DEPARTMENT OF PUBLIC SERVICES

DATE: 09-15-25

DRAWING NO.

# 3-0

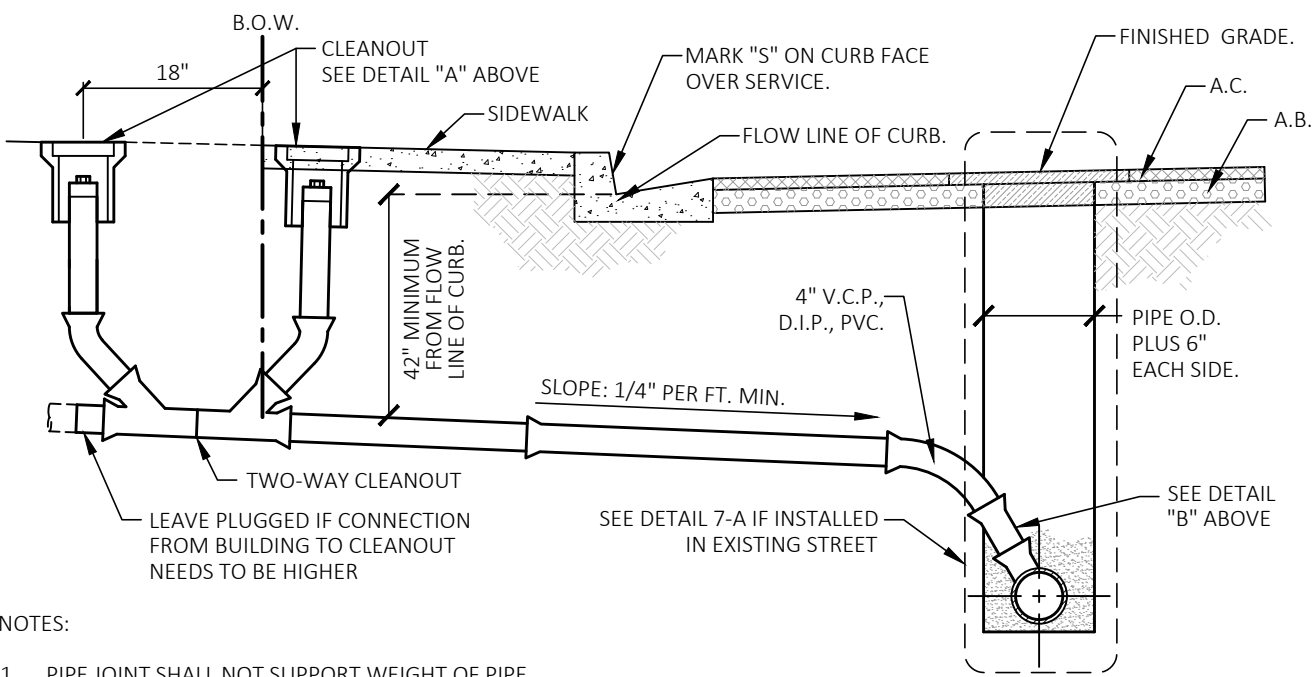
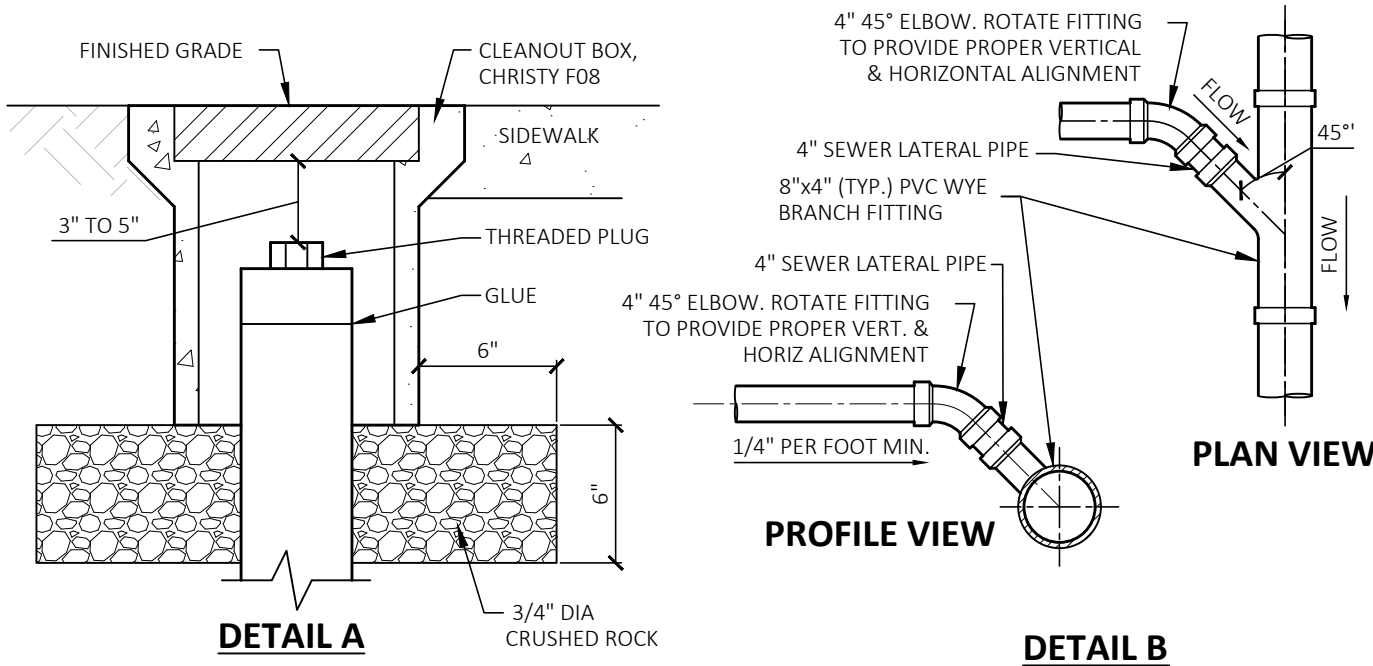

**NOTES:**

1. PIPE JOINT SHALL NOT SUPPORT WEIGHT OF PIPE.
2. LATERAL SIZE TO BE DETERMINED BY DEVELOPER AND APPROVED BY THE CITY ENGINEER.
3. IN STREETS WHERE FLOWLINE OF MAIN SEWER IS MORE THAN 5 FEET BELOW FINISHED GRADE. A RISER WITH A 45° ELBOW MAY BE USED UP TO A POINT 5 FEET BELOW CURB GRADE, OR HOUSE CONNECTION MAY BE PLACED ON A UNIFORM SLOPE UP TO A POINT 3 FT. BELOW TOP OF CURB.
4. IF COVER IS LESS THAN 2'-6", ENCASE PIPE IN CONCRETE, MINIMUM OF 4" THICK.
5. SEWER LATERALS LOCATED IN DRIVEWAYS SHOULD BE AVOIDED WHEN POSSIBLE.
6. HOUSE LATERAL TO BE PLACED UNDER CURB AND SIDEWALK BY DRILLING 8" (MAX. DIA.) TUNNEL AND PLACING PIPE WITH NEOPRENE BANDED JOINTS WHEN STREET IMPROVEMENTS EXIST.

APPROVED BY CITY COUNCIL: RESOLUTION: 2025-094	<h2 style="margin: 0;">SEWER LATERAL</h2>	DATE: 09-15-25
	CITY OF OAKDALE DEPARTMENT OF PUBLIC SERVICES	DRAWING NO.
ROB MARLER, P.E. - CITY ENGINEER		<h1 style="margin: 0;">4-A</h1>

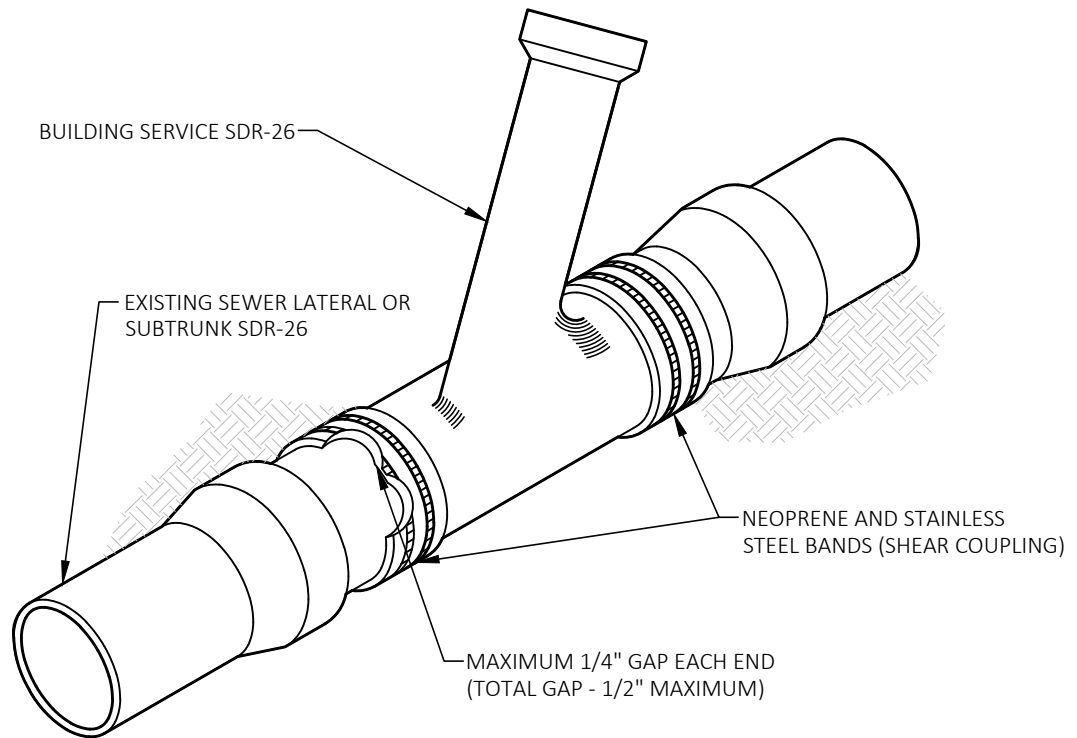

NOTES:

1. A SYNTHETIC RUBBER WEDGED INSERTED TEE, "TAP-TITE", MAY BE SUBSTITUTED FOR THE ABOVE PROCEDURE.
2. CUTS ARE TO BE MADE WITH A PIPE CUTTING TOOL.
3. THERE SHALL BE NO MORE THAN TWO BANDS IN FIVE FEET OF LATERAL OR SUBTRUNK RUN.
4. SHEAR RINGS OF A TYPE APPROVED BY THE ENGINEER SHALL BE INSTALLED ON ALL JOINTS.
5. CUT-IN TEE SHALL BE USED FOR SEWER MAINS 5' OR DEEPER.
6. TEES AND WYES INSTALLED IN MAINS UNDER CONSTRUCTION SHALL BE INSTALLED CONCURRENTLY WITH THE MAIN.
7. ALL FITTINGS, INCLUDING THE JOINTS, SHALL BE OF THE SAME TYPE AND MATERIAL AS THE MAIN.
8. CUT-IN TEES WYES WILL NOT BE PERMITTED ON A MAIN UNDER CONSTRUCTION.

APPROVED BY CITY COUNCIL:  
RESOLUTION: 2025-094

*Rob Marler*

ROB MARLER, P.E. - CITY ENGINEER

## CUT-IN WYE

CITY OF OAKDALE  
DEPARTMENT OF PUBLIC SERVICES

DATE: 09-15-25

DRAWING NO.

**4-B**

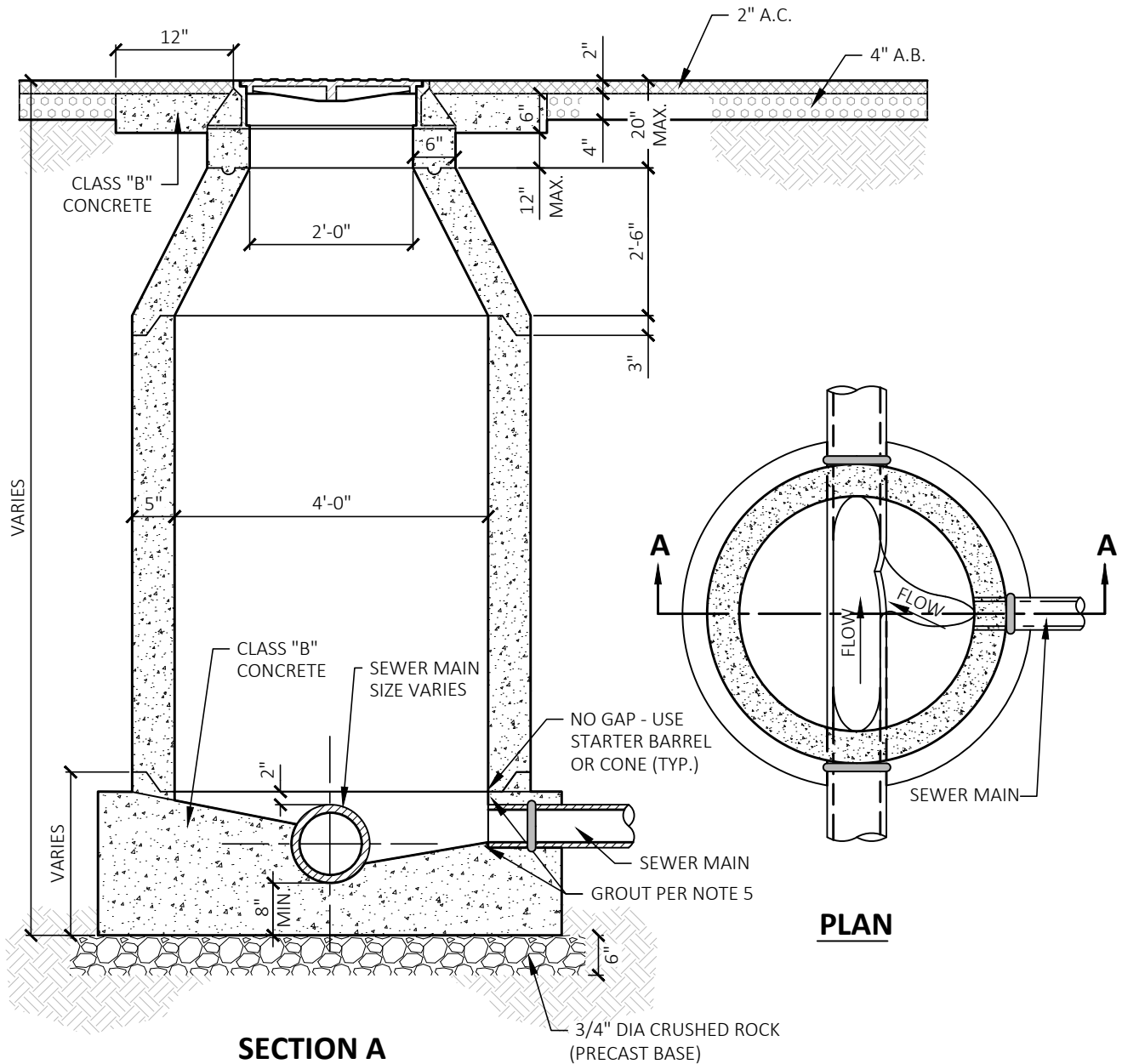

**SECTION A**

**PLAN**

NOTES:

1. 2" TO 3" GRADE ADJUSTING RINGS REINFORCED AS REQUIRED.
2. STANDARD CONCENTRIC CONE SHALL CONFORM TO ASTM C418-61T.
3. STANDARD PRE-CAST MANHOLE SECTIONS SHALL CONFORM TO ASTM C418-61T.
4. BOTTOM OF MANHOLE SHALL BE CONSTRUCTED FROM FLOWLINE TO FLOWLINE AND SHAPED TO CONFORM WITH THE DIAMETER OF THE PIPE AND DIRECTION OF FLOW.
5. GROUT ALL JOINTS. RUBBER GASKET, BELL SPIGOT BARRELS PREFERRED, OR USE "RAM NEK" OR APPROVED EQUAL.
6. MANHOLE COVER TO BE MARKED "SEWER".
7. ADJUST FRAME TO GRADE AFTER PAVING.

APPROVED BY CITY COUNCIL:  
RESOLUTION: 2025-094

*Rob Marler*

ROB MARLER, P.E. - CITY ENGINEER

**SEWER MANHOLE**

CITY OF OAKDALE  
DEPARTMENT OF PUBLIC SERVICES

DATE: 09-15-25

DRAWING NO.

**4-C**

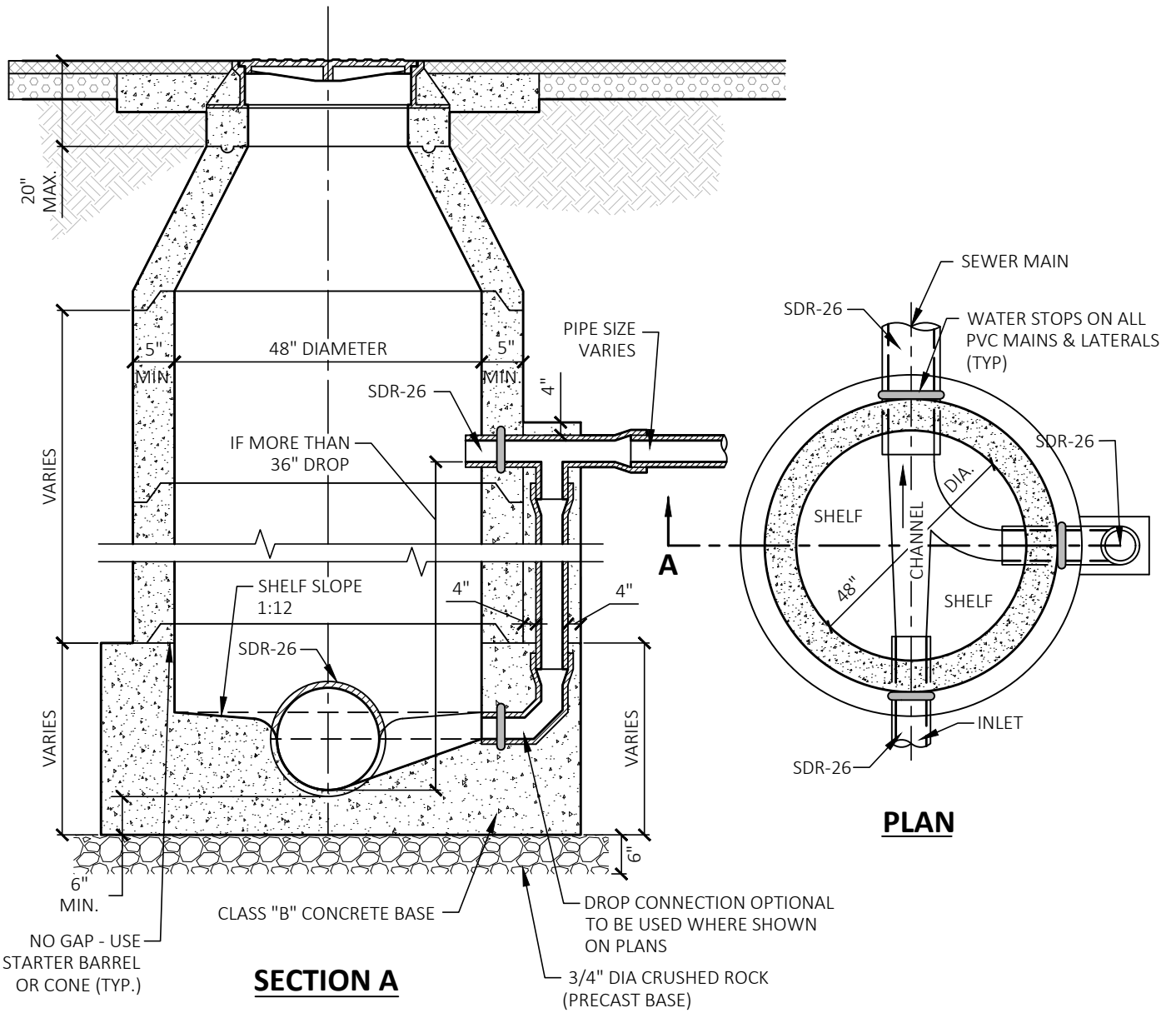

NOTES:

1. USE CONCENTRIC REINFORCED CONCRETE CONE, ECCENTRIC REINFORCED CONCRETE CONE OPTIONAL, TO BE APPROVED BY THE CITY ENGINEER.
2. PIPE SHALL BE LAID THROUGH THE MANHOLE, THEN SMOOTHLY BROKEN OUT AFTER BASE CONCRETE HAS SET. CONCRETE SHALL HAVE A SMOOTH, UNIFORM, STEEL TROWEL FINISH. AFTER PIPE IS BROKEN OUT, ADDITIONAL GROUT SHALL BE APPLIED, AND BRUSHED SMOOTH.
3. WHERE INCOMING AND OUTGOING SEWERS IN MANHOLE VARY IN SIZE, EXTEND LOWER HALVES OF SEWER PIPES BEYOND INSIDE OF WALL AND SHAPE A SMOOTH, EVEN TRANSITION CHANNEL BETWEEN PIPES.
4. MATCH CROWN OF PIPE AT MANHOLES JOINING DIFFERENT SIZE PIPES, IF LARGER IS DOWNSTREAM.
5. DROP MANHOLE ARE TO BE USED IF THERE IS MORE THAN 36" DROP FROM INV. TO INV.

APPROVED BY CITY COUNCIL:  
RESOLUTION: 2025-094

*Rob Marler*

ROB MARLER, P.E. - CITY ENGINEER

**DROP MANHOLE**

CITY OF OAKDALE  
DEPARTMENT OF PUBLIC SERVICES

DATE: 09-15-25

DRAWING NO.

**4-D**

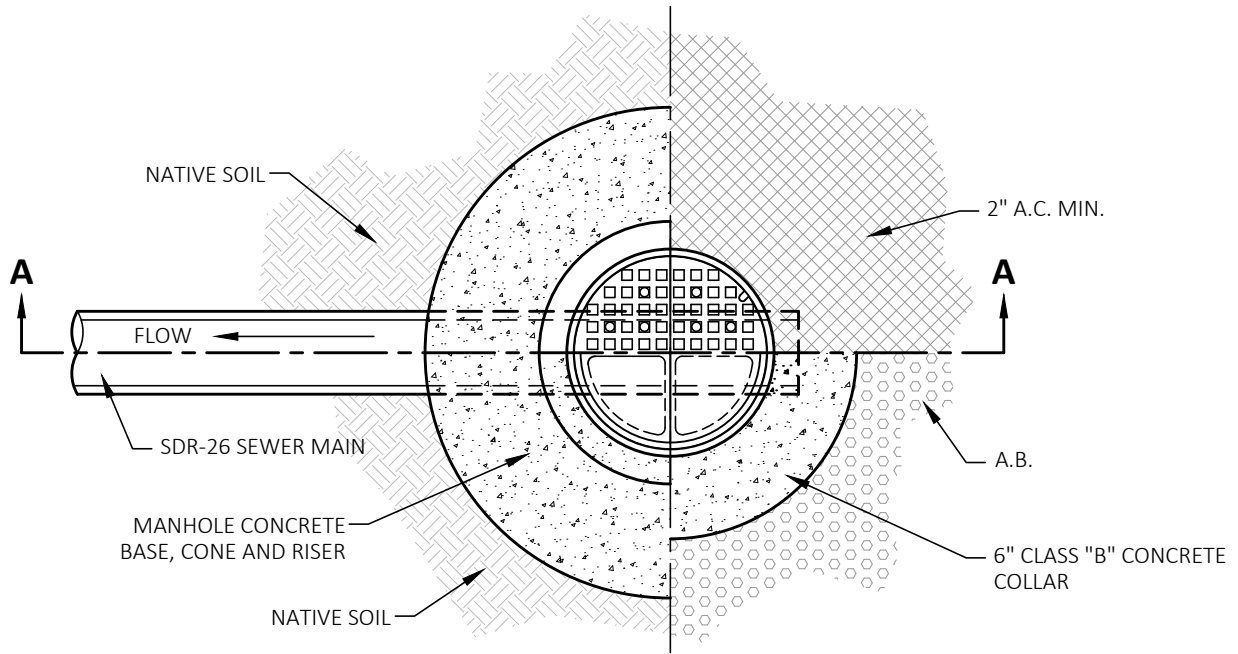

**PLAN**

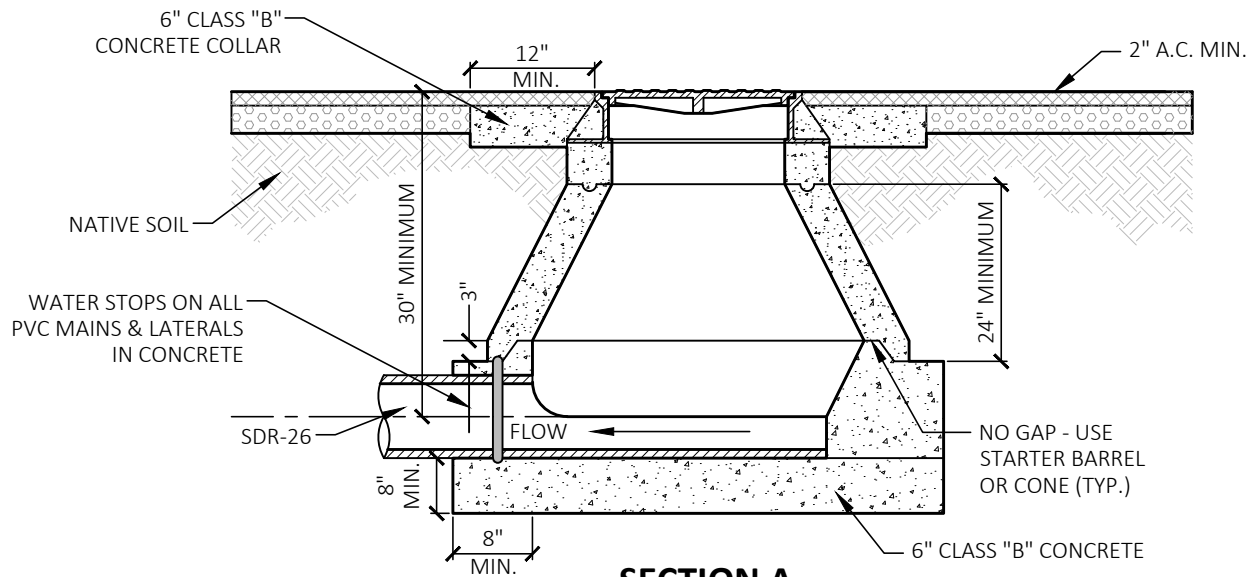

**SECTION A**

NOTES:

1. PINKERTON A-163 MANHOLE ASSEMBLY.
2. FRAME PART NO. A-164 - APPROXIMATE WEIGHT = 230 LBS.
3. COVER PART NO. A-165 - APPROXIMATE WEIGHT = 168 LBS.

APPROVED BY CITY COUNCIL:  
RESOLUTION: 2025-094

*Rob Marler*

ROB MARLER, P.E. - CITY ENGINEER

**TERMINAL CLEANOUT**

CITY OF OAKDALE  
DEPARTMENT OF PUBLIC SERVICES

DATE: 09-15-25

DRAWING NO.

**4-E**

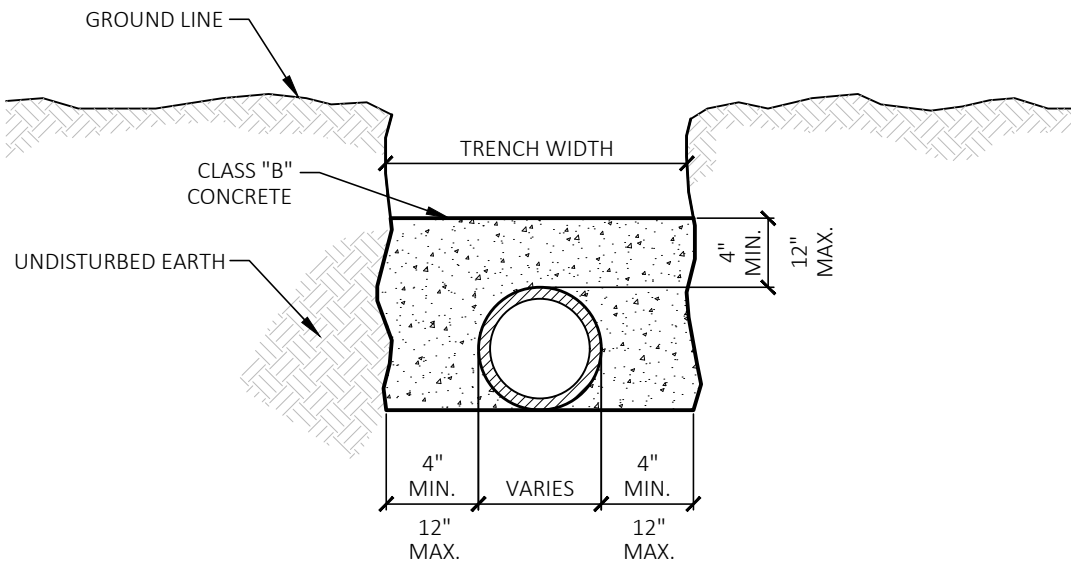
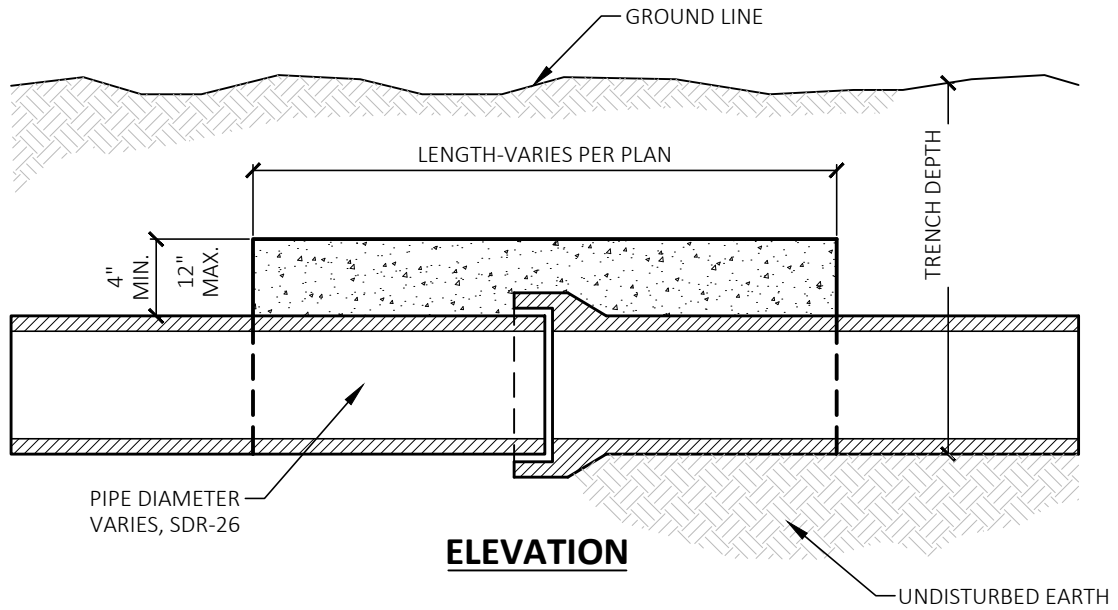

NOTES:

1. CONCRETE TYPE REINFORCEMENT SHALL EXTEND TO UNDISTURBED EARTH.
2. THIS METHOD SHALL ONLY BE USED IF APPROVED BY CITY ENGINEER.

APPROVED BY CITY COUNCIL:  
RESOLUTION: 2025-094

*Rob Marler*

ROB MARLER, P.E. - CITY ENGINEER

**CONCRETE ENCASEMENT**

(IF LESS THAN 30" COVER)

CITY OF OAKDALE  
DEPARTMENT OF PUBLIC SERVICES

DATE: 09-15-25

DRAWING NO.

**4-F**

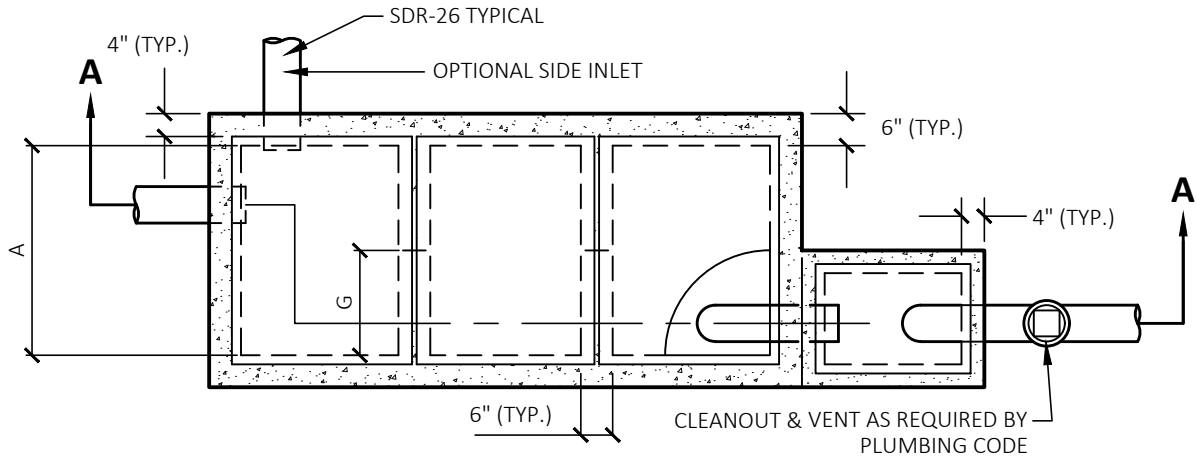

**PLAN**

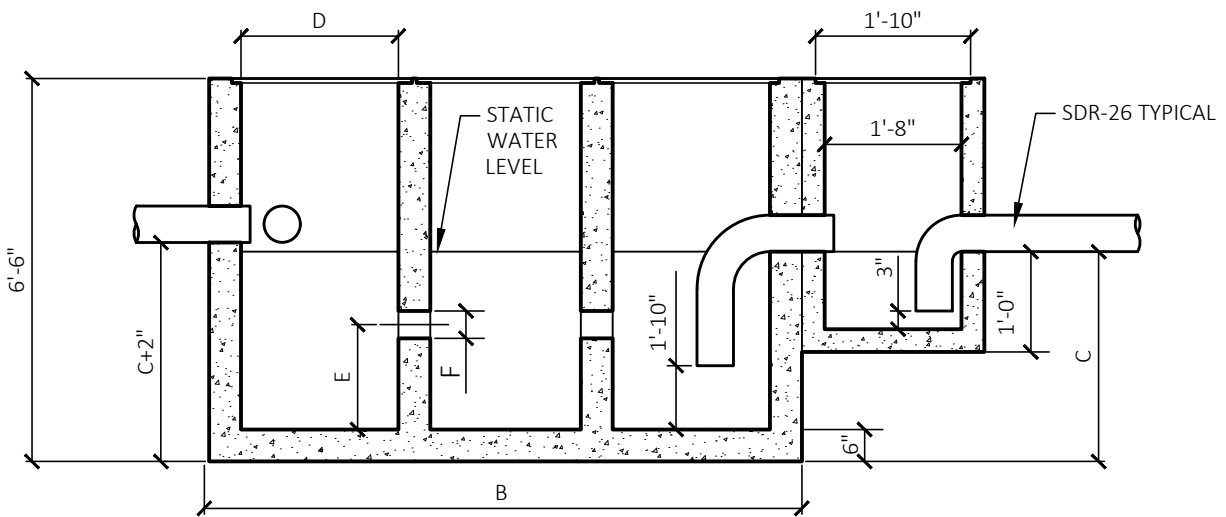

**SECTION A**

CAPACITY GALLONS	DIMENSIONS							COVER SIZE	METAL COVERS	PIPE SIZE
	A	B	C	D	E	F	G			
510	3'-0"	9'-6"	3'-0"	2'-6"	1'-6"	4 1/2"	1'-6"	2'-10" X 3'-4"	1/4" STEEL PLATE	4"
866	3'-5"	10'-3"	4'-0"	2'-5"	2'-0"	0'-6"	1'-9"	3'-10" X 3'-10"	3/8" ALUMINUM PLATE	4"
1260	4'-0"	12'-6"	4'-0"	3'-6"	2'-0"	0'-6"	2'-0"	3'-10" X 4'-4"	3/8" ALUMINUM PLATE	4"

NOTES:

1. TRAFFIC LIDS TO BE INSTALLED IN TRAFFIC AREAS.

APPROVED BY CITY COUNCIL:  
RESOLUTION: 2025-094

*Rob Marler*

ROB MARLER, P.E. - CITY ENGINEER

**SAND & GREASE INTERCEPTOR**

CITY OF OAKDALE  
DEPARTMENT OF PUBLIC SERVICES

DATE: 09-15-25

DRAWING NO.

**4-G**

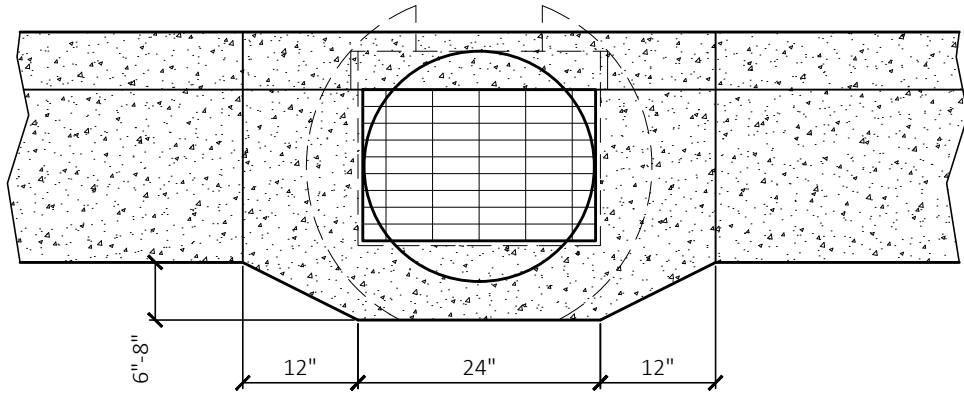

**PLAN**

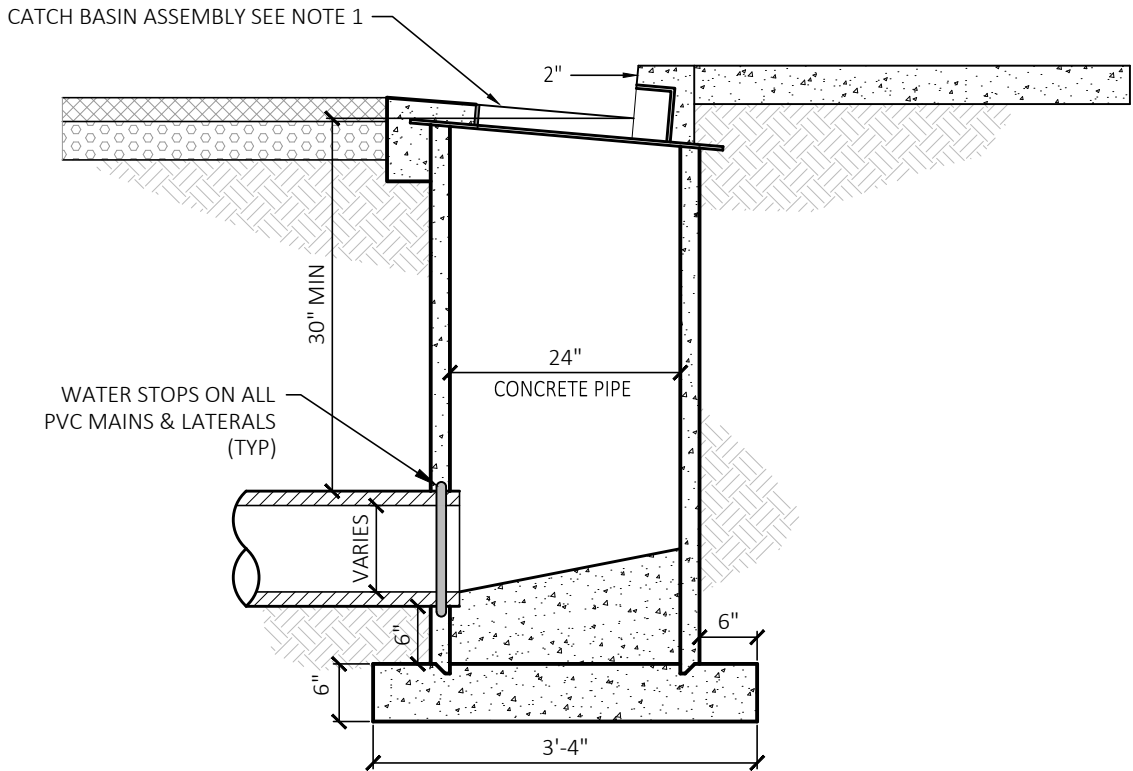

**SECTION**

NOTE:

1. FRAME, SIDE INLET, AND GRATE SHALL CONFORM TO STANDARD SPECIFICATIONS OR APPROVED EQUAL.
2. FRAME AND GRATE SHALL BE GALVANIZED

APPROVED BY CITY COUNCIL:  
RESOLUTION: 2025-094

*Rob Marler*

ROB MARLER, P.E. - CITY ENGINEER

# CATCH BASIN

CITY OF OAKDALE  
DEPARTMENT OF PUBLIC SERVICES

DATE: 09-15-25

DRAWING NO.

**5-A**

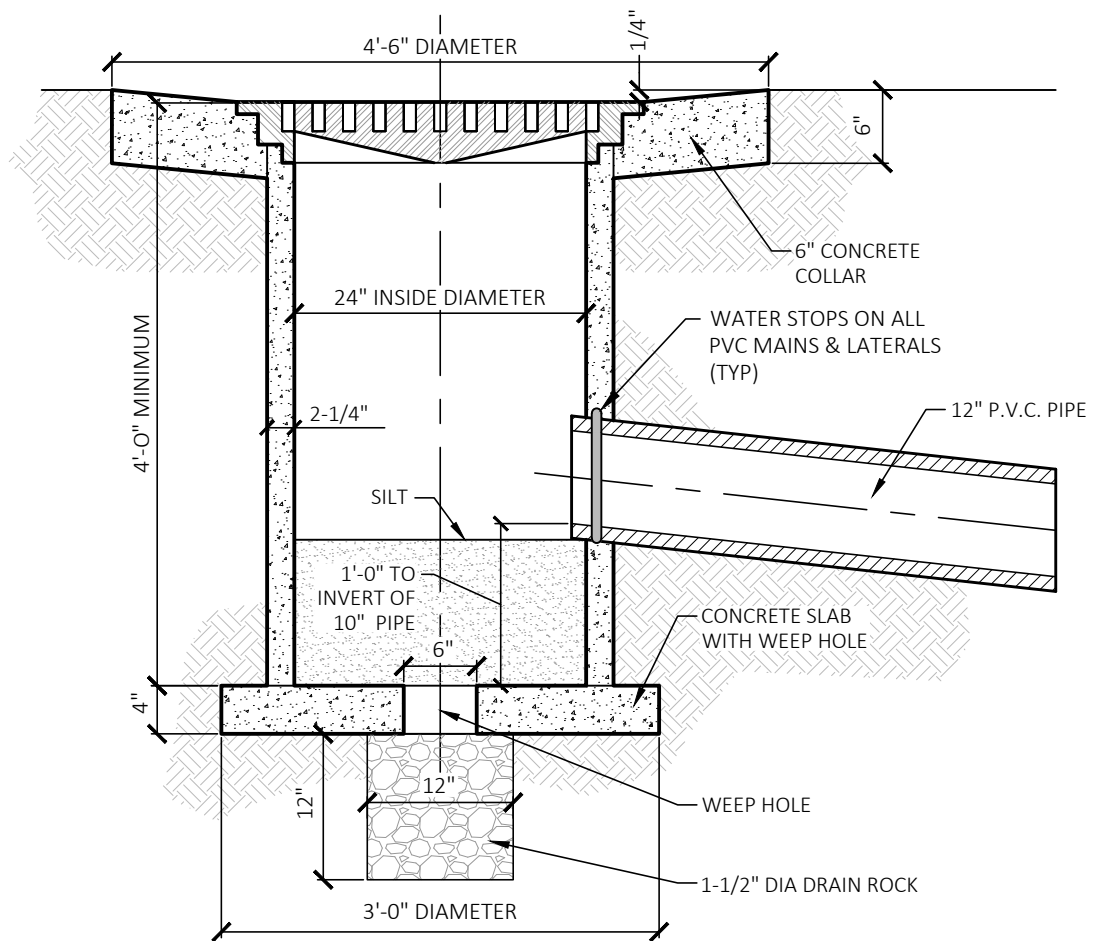
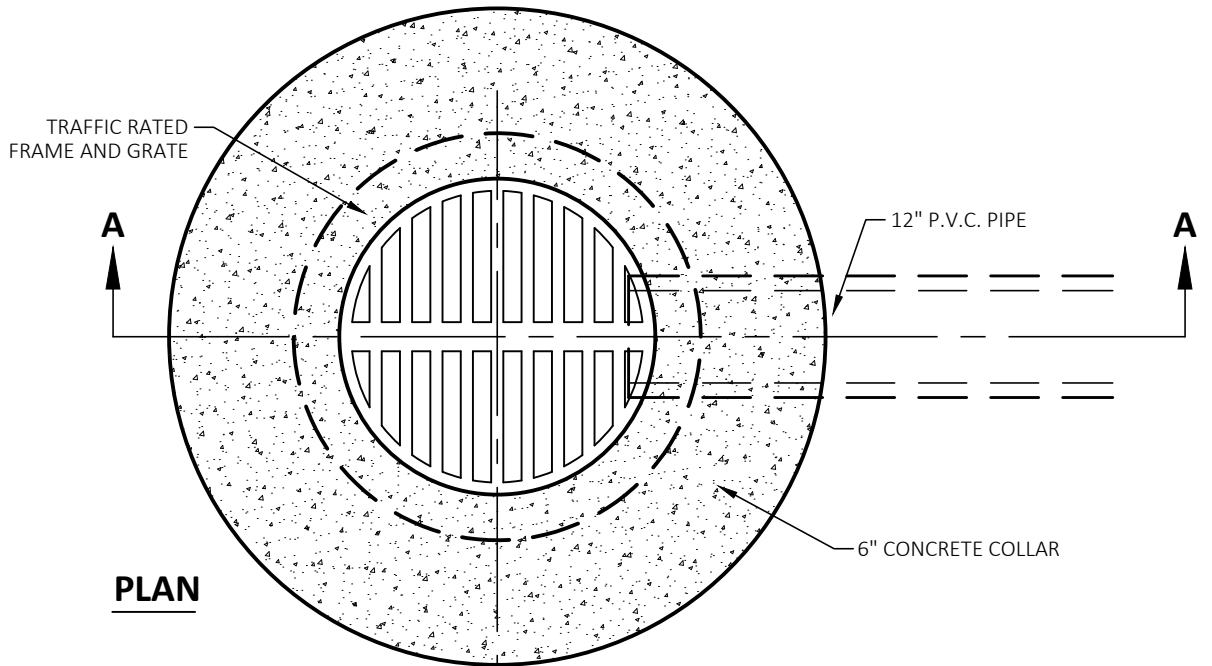

**SECTION A**

APPROVED BY CITY COUNCIL:  
RESOLUTION: 2025-094

*Rob Marler*

ROB MARLER, P.E. - CITY ENGINEER

# CONCRETE PIPE INLET

CITY OF OAKDALE  
DEPARTMENT OF PUBLIC SERVICES

DATE: 09-15-25

DRAWING NO.

## 5-B

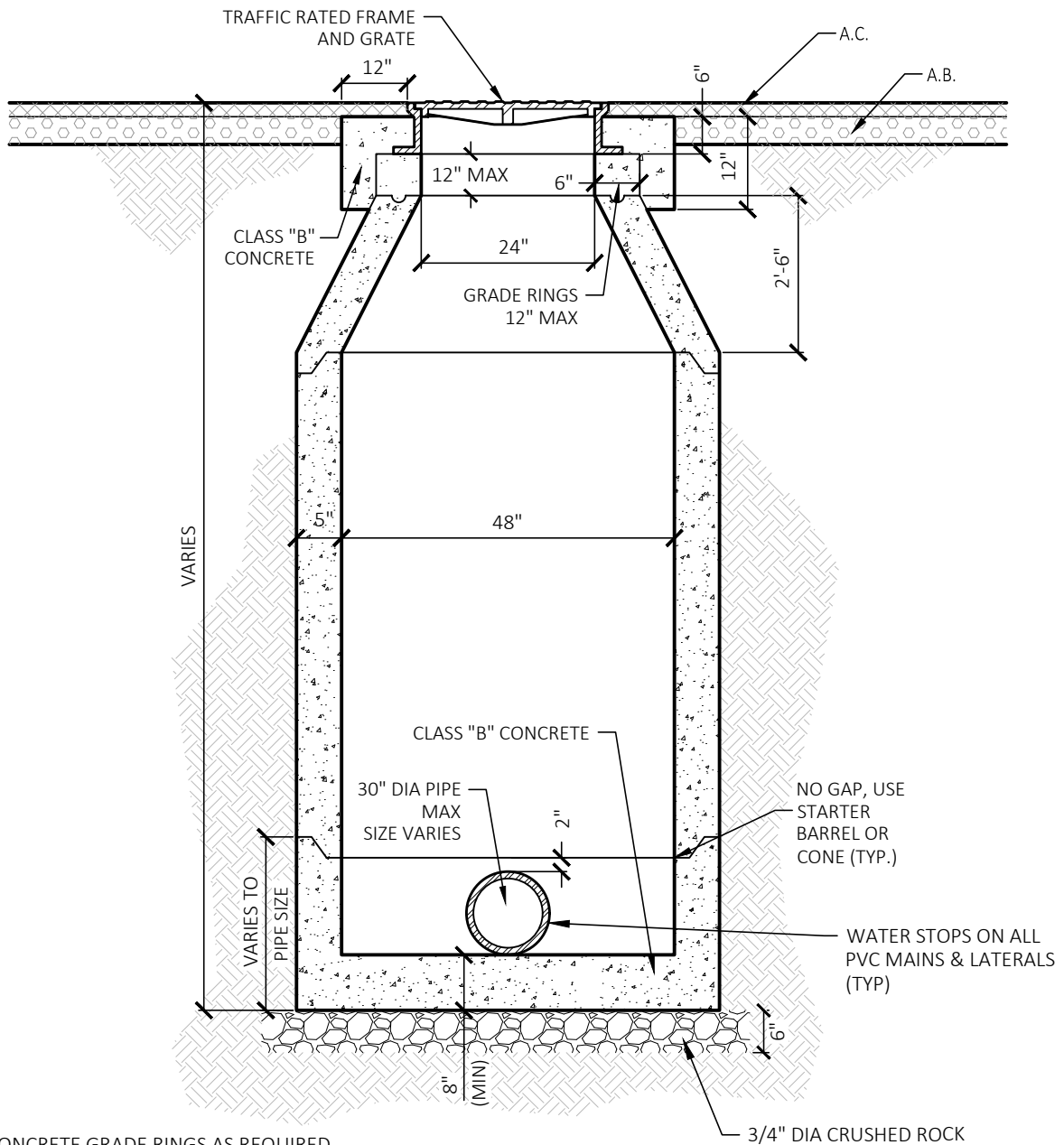

NOTES:

1. 2"-3" CONCRETE GRADE RINGS AS REQUIRED.
2. STANDARD CONCENTRIC CONE SHALL CONFORM TO ASTM C418-61T.
3. STANDARD PRE-CAST MANHOLE SECTIONS SHALL CONFORM TO ASTM C418-61T.
4. BOTTOM OF MANHOLE SHALL BE CONSTRUCTED FROM FLOWLINE TO FLOWLINE AND SHAPED TO CONFORM WITH THE DIAMETER OF THE PIPE AND DIRECTION OF FLOW (MATCH CROWNS).
5. GROUT ALL JOINTS. RUBBER GASKET BELL, SPIGOT BARREL PREFERRED OR USE "RAM NEK" OR APPROVED EQUAL.
6. MANHOLE COVER TO BE MARKED "STORM DRAIN".
7. ADJUST FRAME TO GRADE AFTER PAVING.
8. PVC PIPES MUST HAVE WATERTIGHT SEAL (DOUGHNUT).

APPROVED BY CITY COUNCIL:  
RESOLUTION: 2025-094

*Rob Marler*

ROB MARLER, P.E. - CITY ENGINEER

# STORM DRAIN MANHOLE

CITY OF OAKDALE  
DEPARTMENT OF PUBLIC SERVICES

DATE: 09-15-25

DRAWING NO.

# 5-C

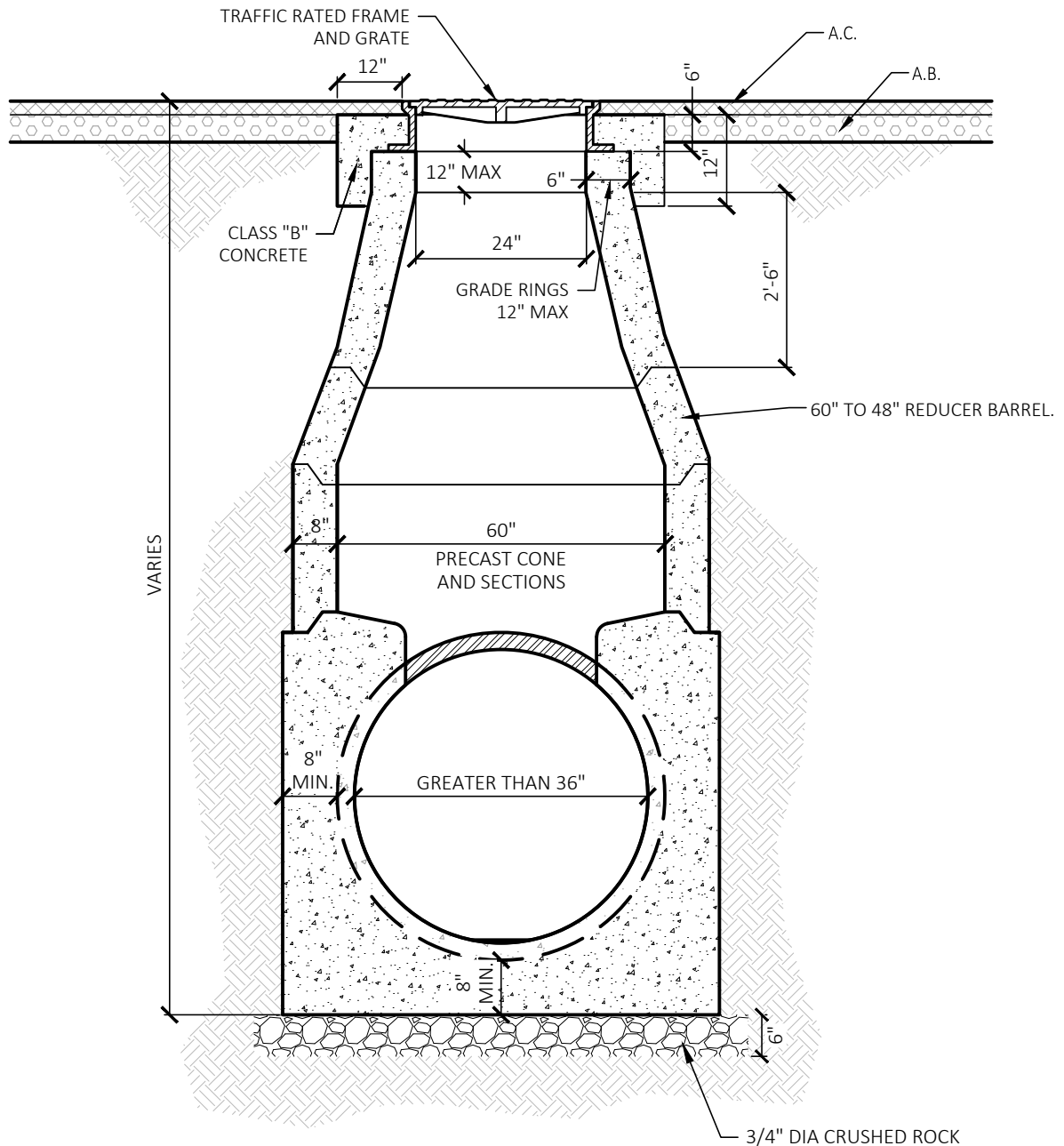

NOTES:

1. 2"- 3" GRADE ADJUSTING RINGS REINFORCED AS REQUIRED.
2. STANDARD CONCENTRIC CONE SHALL CONFORM TO ASTM C418-61T.
3. STANDARD PRE-CAST MANHOLE SECTIONS SHALL CONFORM TO ASTM C418-61T.
4. BOTTOM OF MANHOLE SHALL BE CONSTRUCTED FROM FLOWLINE TO FLOWLINE AND SHAPED TO CONFORM WITH THE DIAMETER OF THE PIPE AND DIRECTION OF FLOW.
5. GROUT ALL JOINTS, RUBBER GASKET BELL SPIGOT BARREL PREFERRED OR USE "RAM NEK" OR APPROVED EQUAL.
6. MANHOLE COVER TO BE MARKED SEWER OR STORM DRAIN.
7. ADJUST FRAME TO GRADE AFTER PAVING.

APPROVED BY CITY COUNCIL:  
RESOLUTION: 2025-094

*Rob Marler*

ROB MARLER, P.E. - CITY ENGINEER

# LARGE TRUNK MANHOLE

CITY OF OAKDALE  
DEPARTMENT OF PUBLIC SERVICES

DATE: 09-15-25

DRAWING NO.

## 5-D

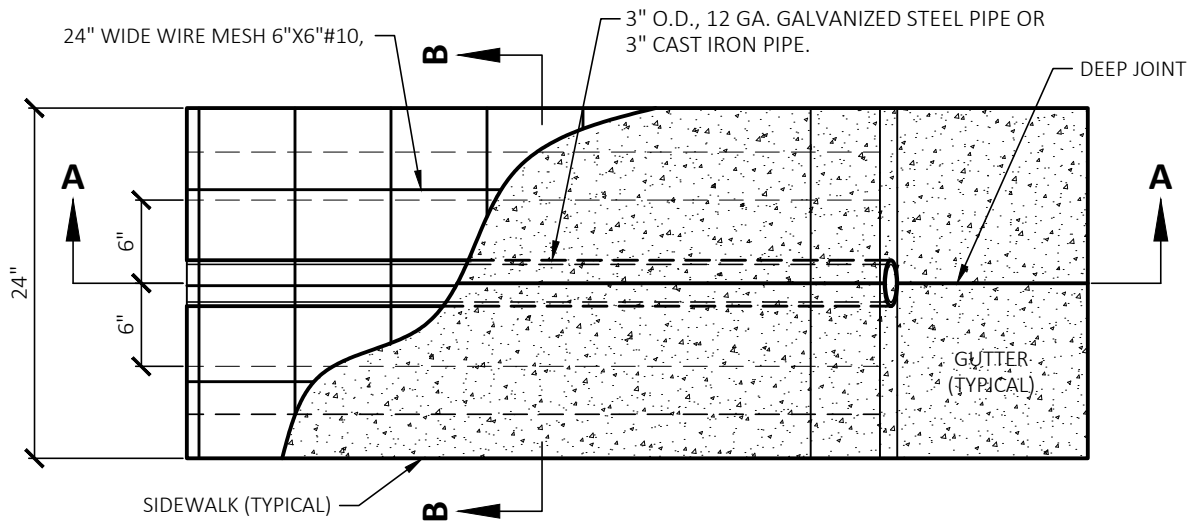

**PLAN**

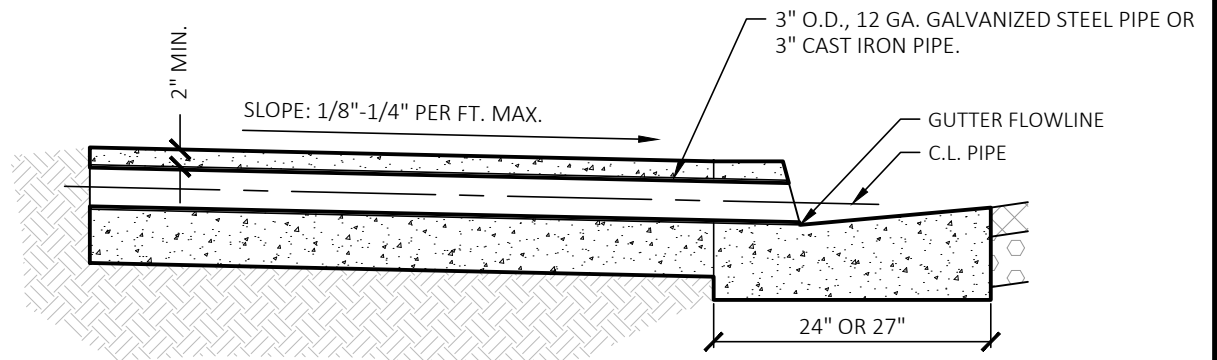

**SECTION A**

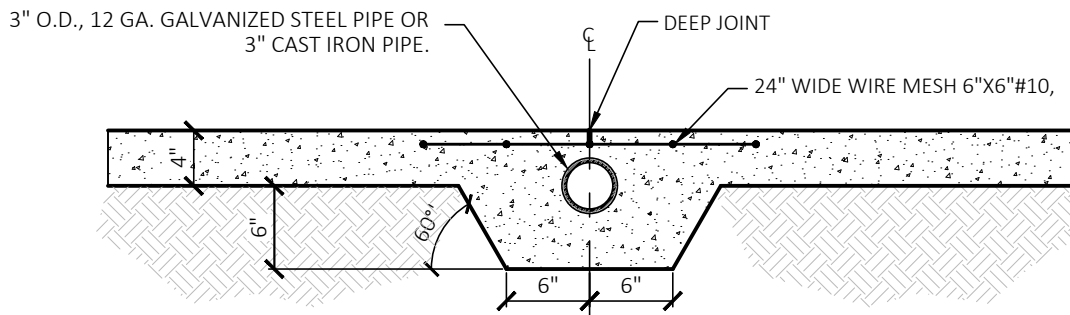

**SECTION B**

APPROVED BY CITY COUNCIL:  
RESOLUTION: 2025-094

*Rob Marler*

ROB MARLER, P.E. - CITY ENGINEER

**SIDEWALK DRAIN**

CITY OF OAKDALE  
DEPARTMENT OF PUBLIC SERVICES

DATE: 09-15-25

DRAWING NO.

**5-E**

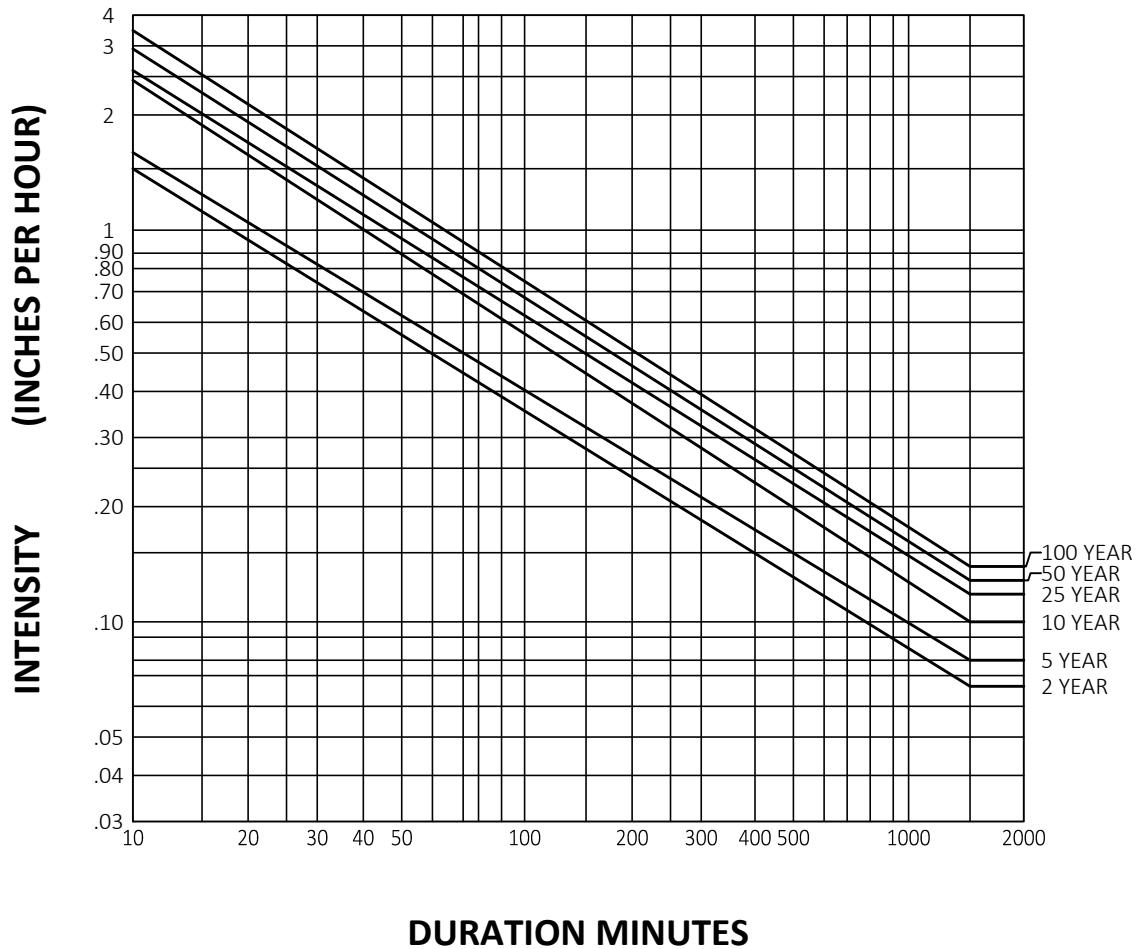

NOTES:

1. THESE RAINFALL INTENSITY CURVES ARE BASED ON CALIFORNIA DEPARTMENT OF WATER RESOURCES DATA ACCORDING TO COUNTY OF STANISLAUS 1989.
2. MINIMUM RETURN FREQUENCY FOR STORM DRAINAGE COLLECTION FACILITIES SHALL BE 5-YEAR.
3. MINIMUM RETURN FREQUENCY FOR CULVERTS AND RETENTION BASINS SHALL BE 5-YEAR.

APPROVED BY CITY COUNCIL:  
RESOLUTION: 2025-094

*Rob Marler*

ROB MARLER, P.E. - CITY ENGINEER

# RAINFALL INTENSITY CURVES

CITY OF OAKDALE  
DEPARTMENT OF PUBLIC SERVICES

DATE: 09-15-25

DRAWING NO.

**5-F**

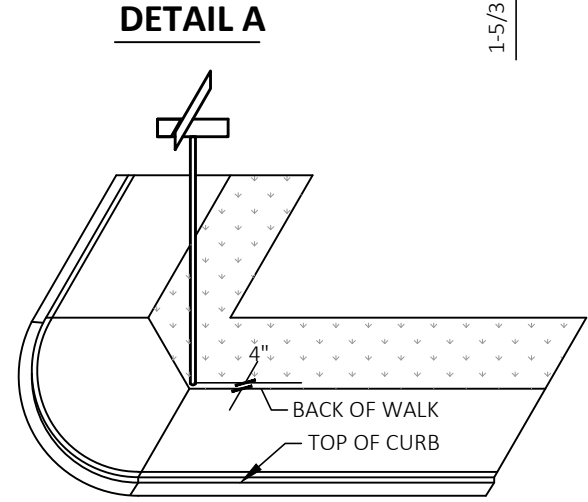
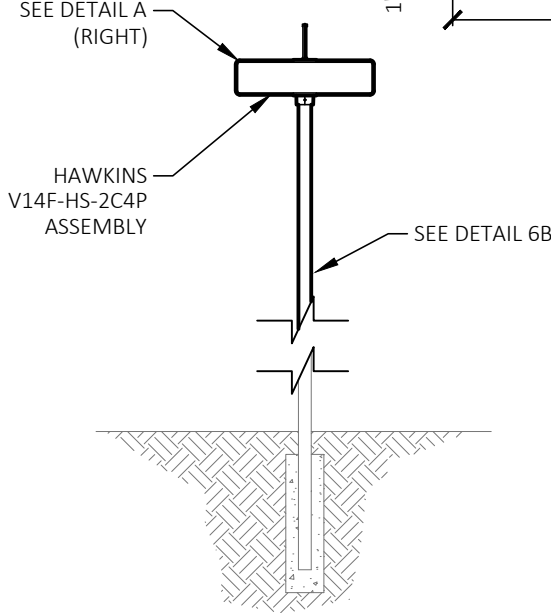
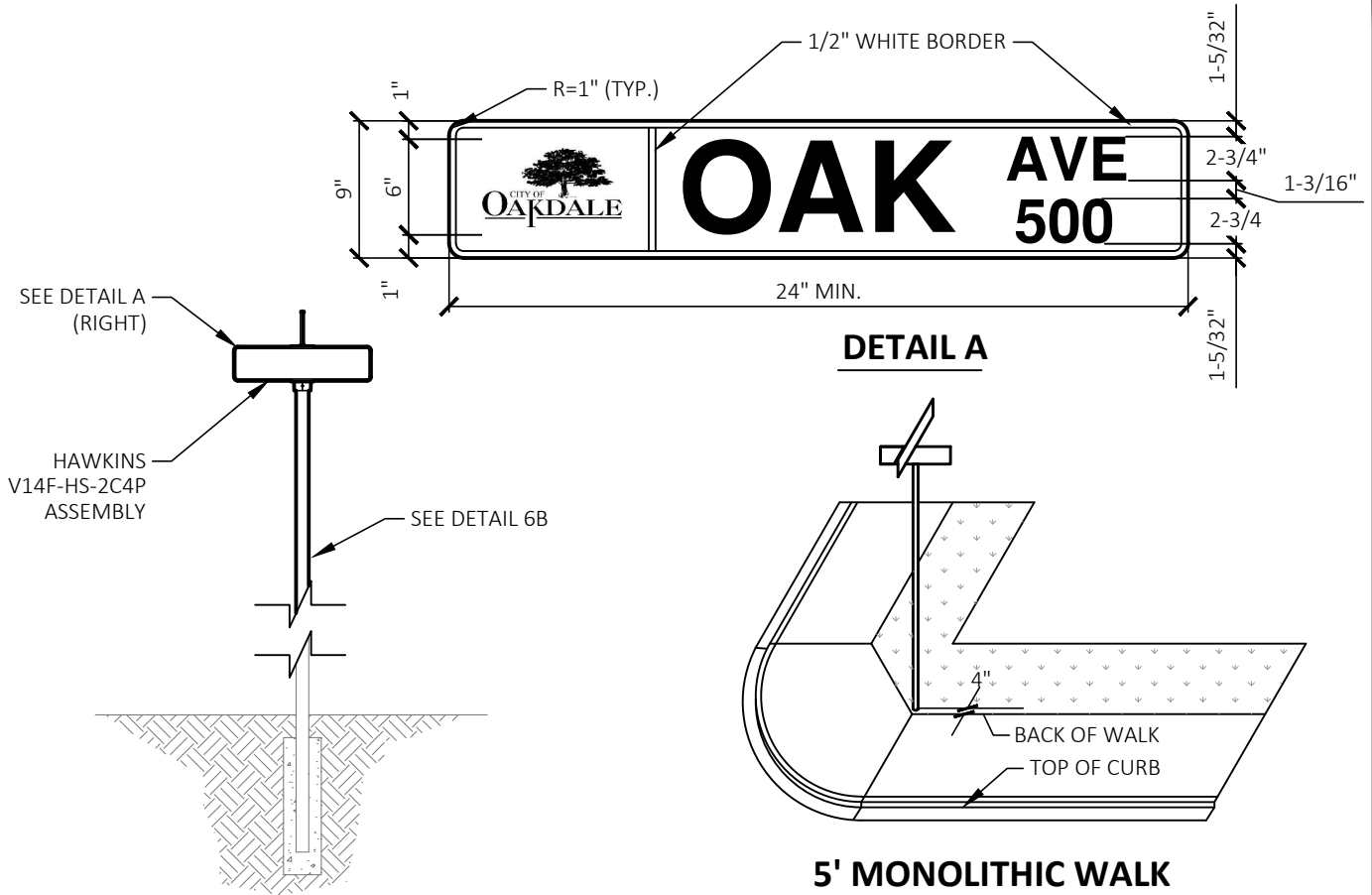

**5' MONOLITHIC WALK**

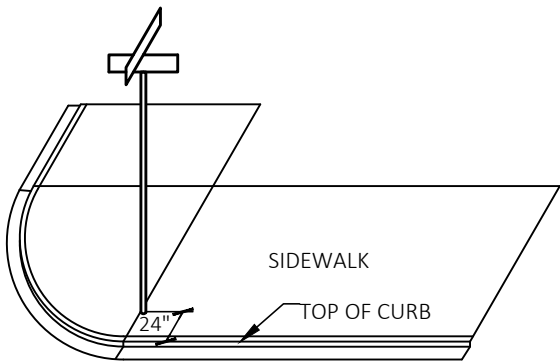

**10' MONOLITHIC WALK**

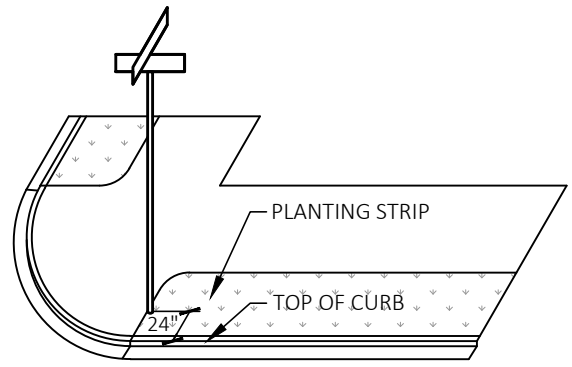

**PLANTER STRIP**

NOTES:

1. SINGLE-BLADE SIGN SHALL BE .080 ALUMINUM BLANKS, WITH DOUBLE-SIDED TEXT.
2. FACE(S) OF SIGN WILL BE "SCOTCHLITE" WITH DIAMOND GRADE REFLECTIVITY, PER MUTCD STANDARDS. COLOR SHALL BE BROWN.
3. LETTERS - 6" SERIES "B" REFLECTIVE, HEAT ACTIVATED (WHITE).
4. LETTERS - 2 3/4" SERIES "B" REFLECTIVE, HEAT ACTIVATED (WHITE).

APPROVED BY CITY COUNCIL:  
RESOLUTION: 2025-094

*Rob Marler*

ROB MARLER, P.E. - CITY ENGINEER

**STREET NAME SIGN**

CITY OF OAKDALE  
DEPARTMENT OF PUBLIC SERVICES

DATE: 09-15-25

DRAWING NO.

**6-A**

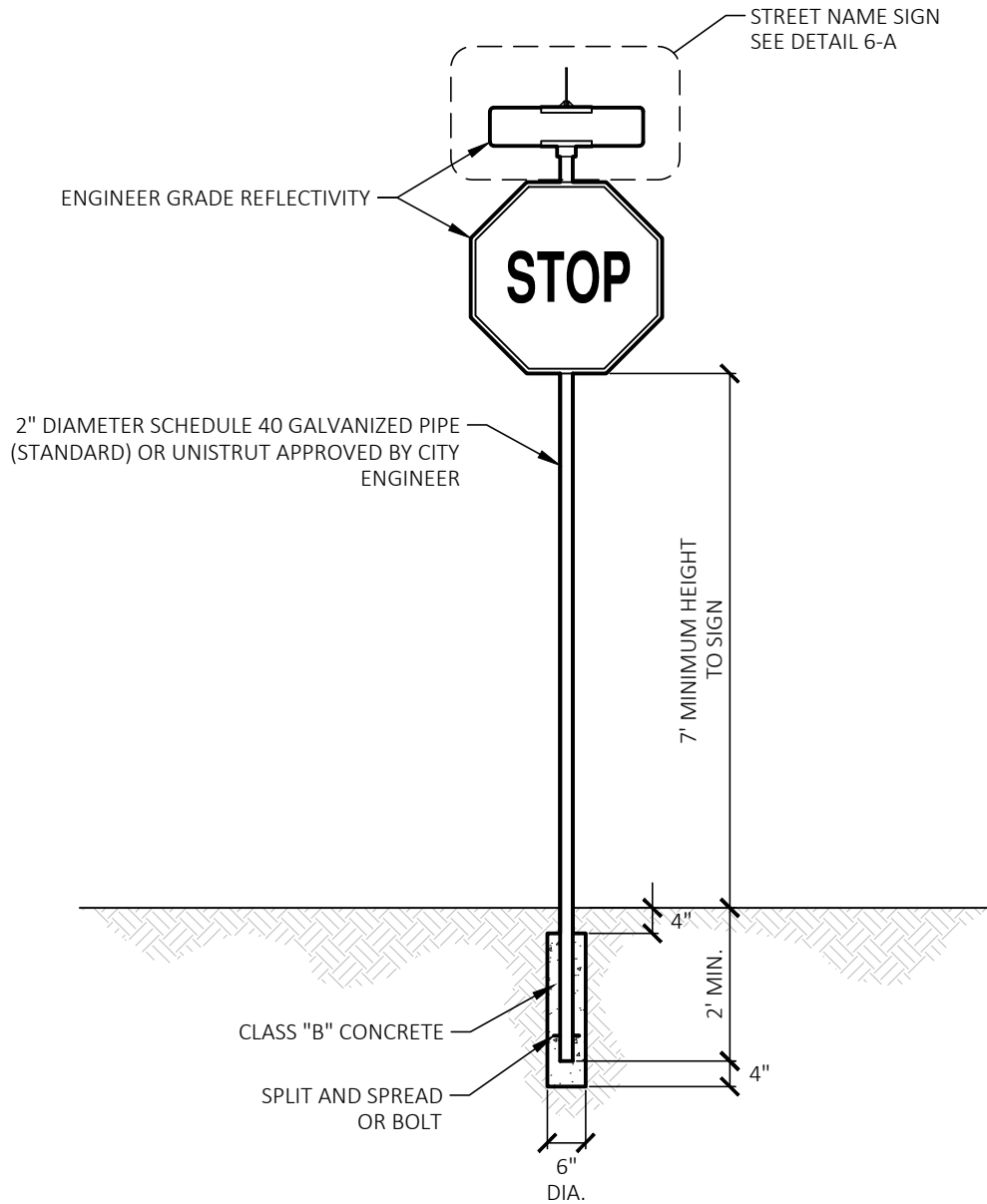

NOTES:

1. ALL SIGNS SHALL HAVE ENGINEER GRADE REFLECTIVITY, PER MUTCD STANDARDS.

APPROVED BY CITY COUNCIL:  
RESOLUTION: 2025-094

*Rob Marler*

ROB MARLER, P.E. - CITY ENGINEER

# STOP SIGN

CITY OF OAKDALE  
DEPARTMENT OF PUBLIC SERVICES

DATE: 09-15-25

DRAWING NO.

# 6-B

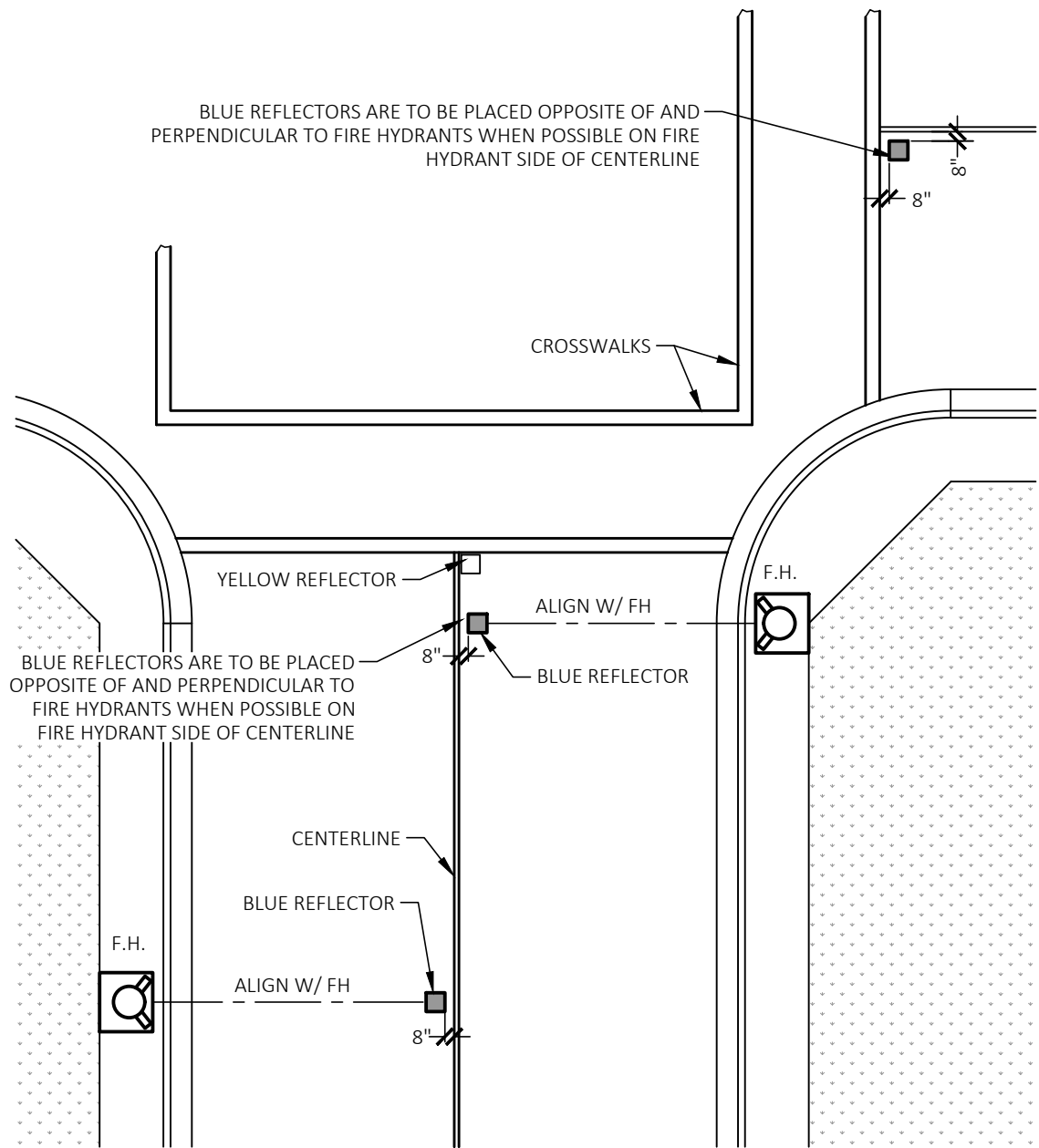

NOTES:

1. BLUE REFLECTORS ARE TO BE PLACED OPPOSITE OF AND PERPENDICULAR TO FIRE HYDRANTS WHEN POSSIBLE ON FIRE HYDRANT SIDE OF CENTERLINE.
2. BLUE REFLECTORS MAY NOT BE PLACED CLOSER THAN 8' TO CROSSWALKS, OR 8" FROM FIRE HYDRANT SIDE OF CENTERLINE.

APPROVED BY CITY COUNCIL:  
RESOLUTION: 2025-094

*Rob Marler*

ROB MARLER, P.E. - CITY ENGINEER

# BLUE REFLECTOR PLACEMENT

CITY OF OAKDALE  
DEPARTMENT OF PUBLIC SERVICES

DATE: 09-15-25

DRAWING NO.

## 6-C

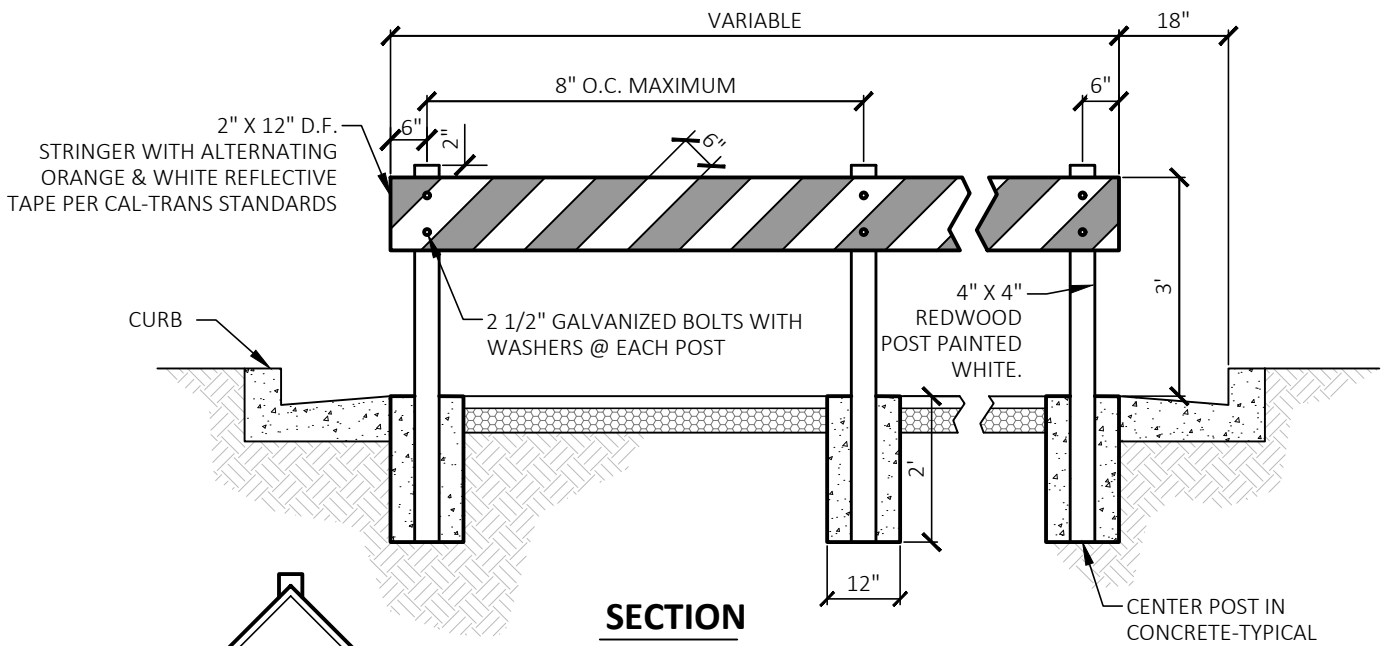

**SECTION**

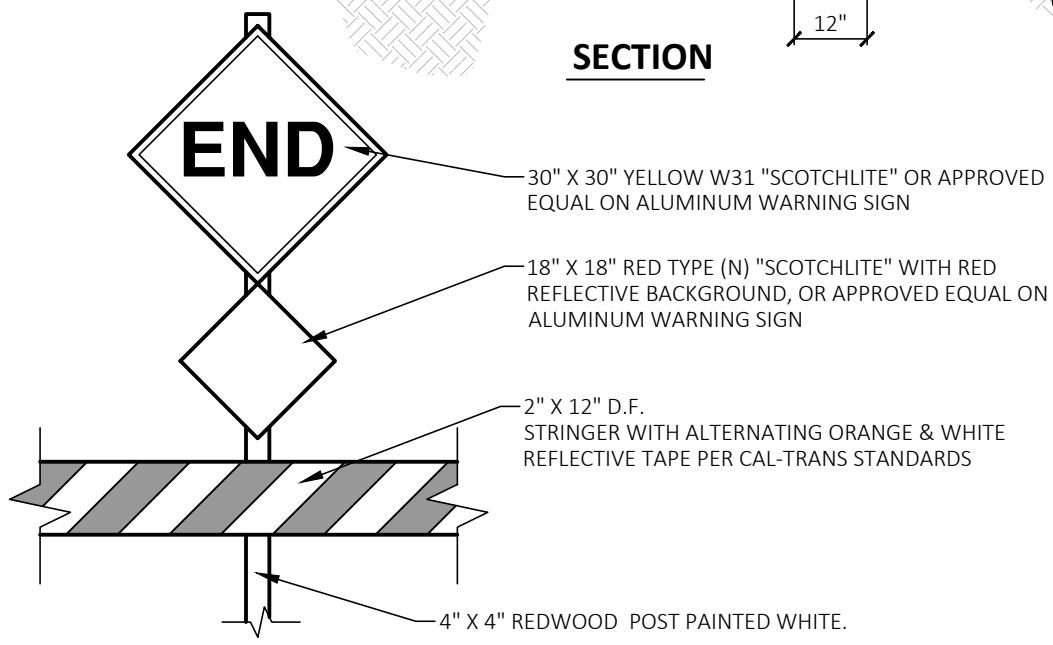

**DETAIL A**

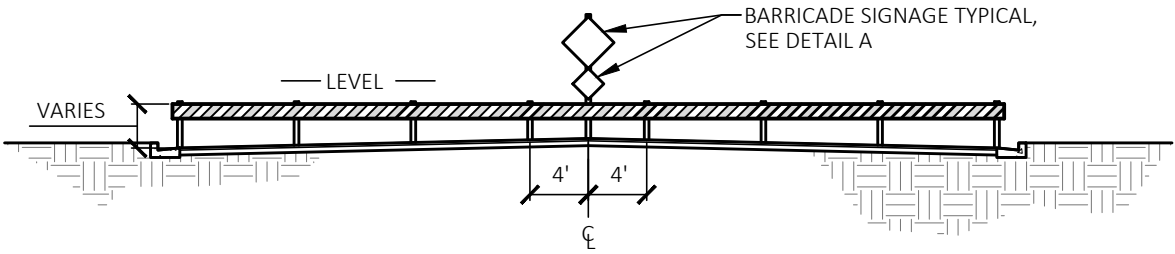

**ELEVATION**

APPROVED BY CITY COUNCIL:  
RESOLUTION: 2025-094

*Rob Marler*

ROB MARLER, P.E. - CITY ENGINEER

**BARRICADE  
DEAD END STREET**

CITY OF OAKDALE  
DEPARTMENT OF PUBLIC SERVICES

DATE: 09-15-25

DRAWING NO.  
**6-D**

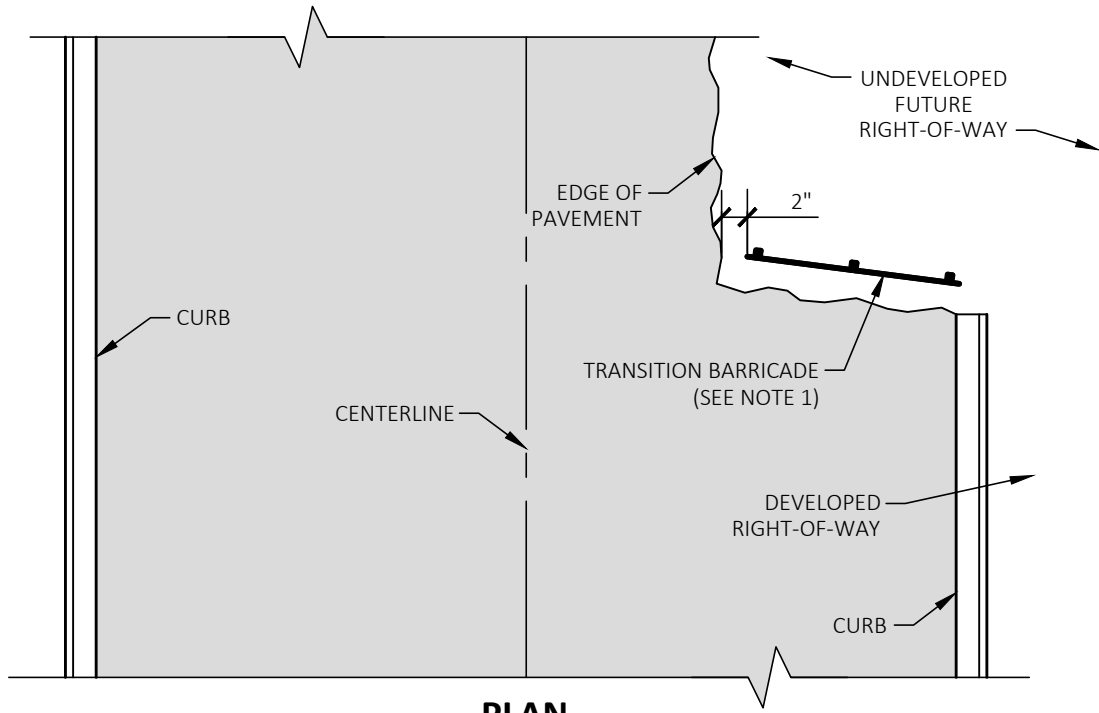

**PLAN**

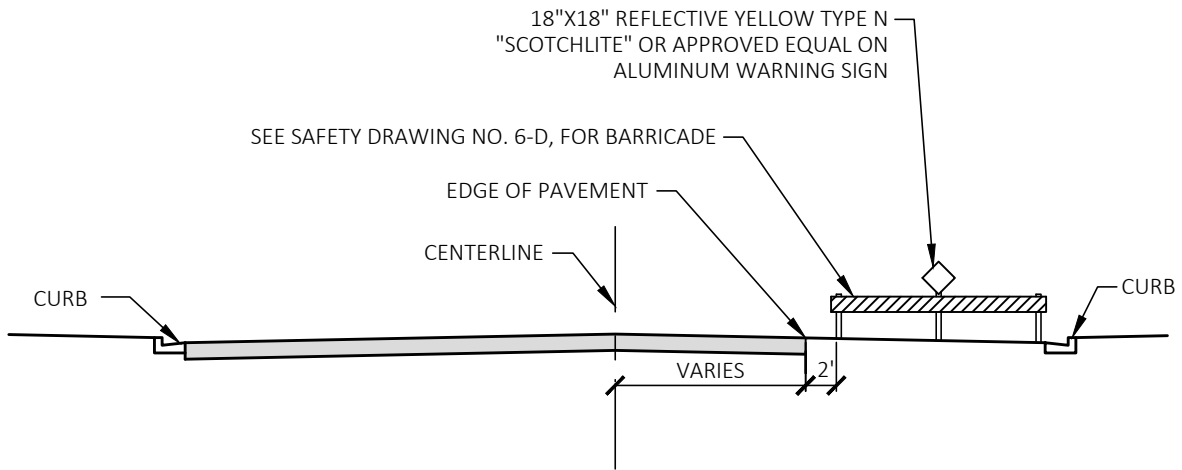

**PROFILE**

NOTES:

1. ALTERNATE LOCATION SHALL BE AS APPROVED BY THE ENGINEER.
2. SEE SAFETY DRAWING NO. 6-D, FOR BARRICADE.
3. 18"X18" REFLECTIVE YELLOW TYPE N "SCOTCHLITE" OR APPROVED EQUAL ON ALUMINUM WARNING SIGN.

APPROVED BY CITY COUNCIL:  
RESOLUTION: 2025-094

*Rob Marler*

ROB MARLER, P.E. - CITY ENGINEER

**BARRICADE  
STREET TRANSITION**

CITY OF OAKDALE  
DEPARTMENT OF PUBLIC SERVICES

DATE: 09-15-25

DRAWING NO.

**6-E**

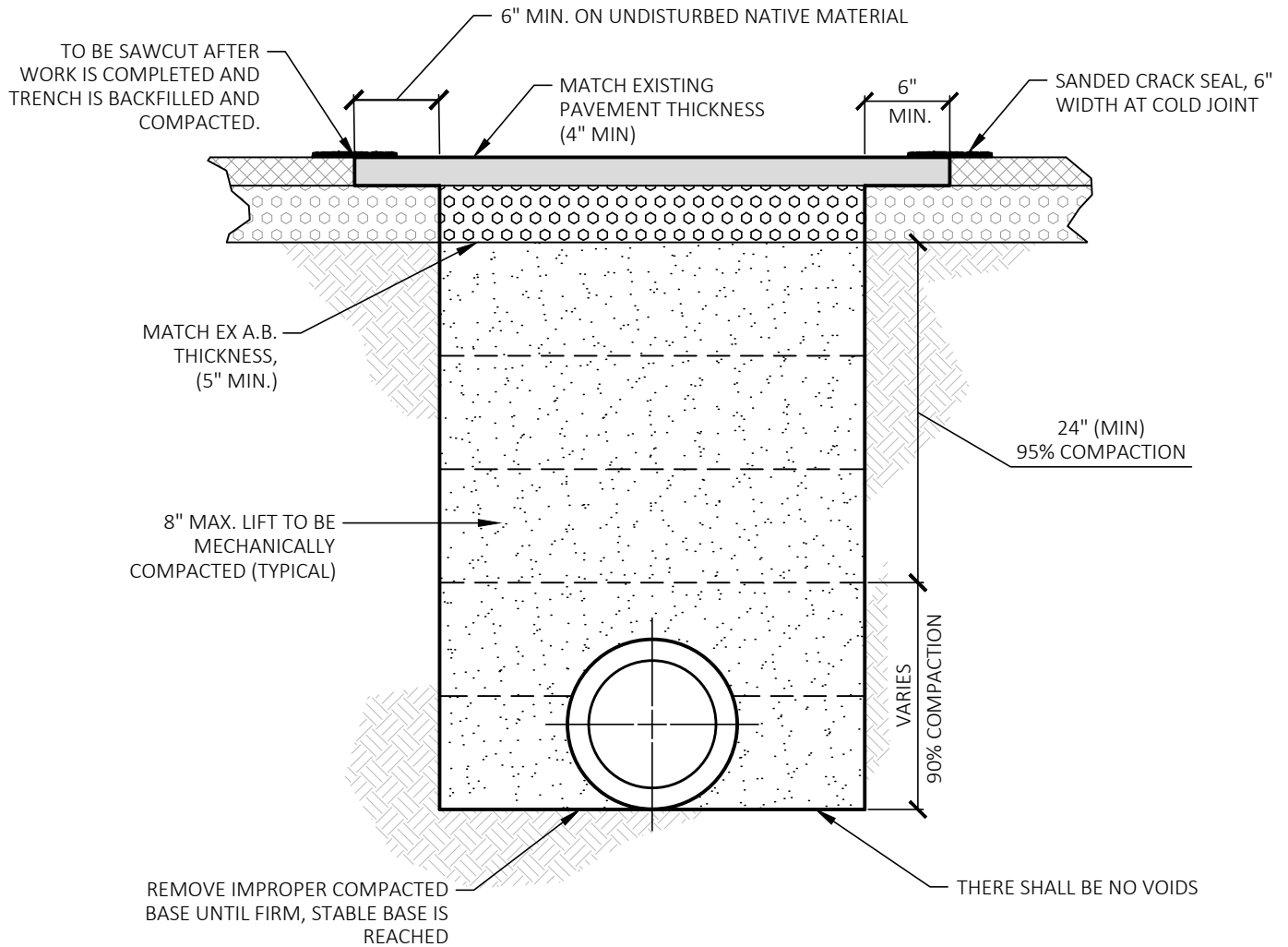

NOTE:

1. BACKFILL SHALL BE OF A MATERIAL APPROVED BY THE ENGINEER.
2. APPLY TACK COAT PER CALTRANS SECTION 94 TO EDGES OF EXISTING PAVEMENT BEFORE PAVING TRENCH.
3. IF TRENCH EXCEEDS 100' IN LENGTH, OR 2/3 OF A TRAVEL LANE A SLURRY SEAL SHALL BE APPLIED TO THE FULL WIDTH OF THE ROAD..
4. IF DISTANCE BETWEEN TRENCHES IS LESS THAN 4 FEET, THE PAVEMENT BETWEEN THE TRENCHES MUST BE RECONSTRUCTED..

APPROVED BY CITY COUNCIL:  
RESOLUTION: 2025-094

*Rob Marler*

ROB MARLER, P.E. - CITY ENGINEER

# TRENCH BACKFILL T-CUT

CITY OF OAKDALE  
DEPARTMENT OF PUBLIC SERVICES

DATE: 09-15-25

DRAWING NO.

**7-A**

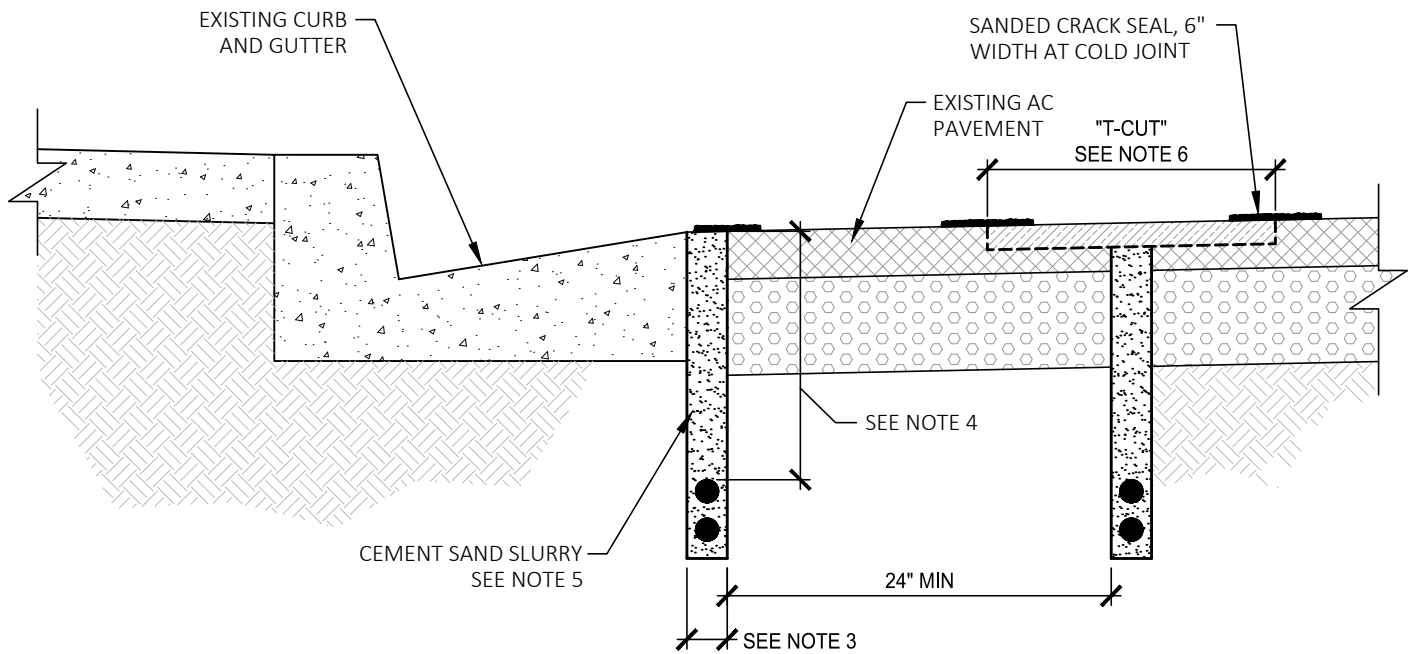

NOTES:

1. MICROTRENCHING SHALL ONLY OCCUR WITHIN EXISTING ASPHALT OF PAVED STREETS. NO MICROTRENCHING SHALL OCCUR IN OR THROUGH EXISTING CONCRETE PAVED STREETS, PARKWAY STRIPS, CURB, GUTTER, VALLEY GUTTER, SIDEWALK, RAISED CROSSWALK, ETC.
2. CONTRACTOR SHALL MAKE ALL REASONABLE EFFORTS TO ACHIEVE STRAIGHT AND UNIFORM CUTS WITH NEAT EDGES. SELECTION OF CUTTING WHEEL SHALL BE SUCH THAT IT MINIMIZES DAMAGE TO THE ADJACENT AC SURFACE. RADIUS TRENCH CUTS SHALL HAVE NO MORE THAN 3 CUTS.
3. MICROTRENCH WIDTH SHALL BE A MINIMUM OF 1 INCH AND A MAXIMUM OF 2.5 INCHES.
4. THE TOP OF THE HIGHEST CONDUIT SHALL BE A MINIMUM OF 15 INCHES FROM THE TOP OF PAVEMENT OR 4 INCHES FROM THE BOTTOM OF THE PAVEMENT SECTION AGGREGATE BASE, WHICHEVER IS GREATER. MICROTRENCH DEPTH SHALL BE 24 INCHES MAX.
5. ALL MICROTRENCHES SHALL BE COMPLETELY BACKFILLED WITH A CEMENT SAND SLURRY, 2500 PSI MINIMUM, TO FINISH GRADE. SLURRY SHALL BE ALLOWED TO CURE FOR A MINIMUM OF 3 HOURS PRIOR TO ALLOWING TRAFFIC ONTO TRENCH AREAS.
6. WHERE MICROTRENCHING OCCURS ADJACENT TO THE LIP OF GUTTER, OR ON ROADWAYS WITH A PAVEMENT CONDITION INDEX (PCI) LESS THAN 50, NO ADDITIONAL PAVEMENT RESTORATION SHALL BE REQUIRED. MICROTRENCHING WITHIN A PAVED ROADWAY WITH A PCI GREATER THAN 50 WILL REQUIRE A T-CUT (MINIMUM 18 INCH WIDTH) TO A MINIMUM DEPTH OF 1.5 INCHES. T-CUT SHALL BE PAVED WITH 1/2" TYPE B ASPHALT. TACK ALL EDGES WITH ASPHALTIC EMULSION PRIOR TO PAVING. SURFACE PREPARATION AND PAVEMENT RESTORATION SHALL OCCUR NO SOONER THAN 48 HOURS AFTER SLURRY BACKFILL OF TRENCH.
7. SPECIFIC ROAD PCI VALUES ARE AVAILABLE UPON REQUEST.

APPROVED BY CITY COUNCIL:  
RESOLUTION:

*Rob Marler*

ROB MARLER, P.E. - CITY ENGINEER

# MICROTRENCHING

CITY OF OAKDALE  
DEPARTMENT OF PUBLIC SERVICES

DATE: 06-15-26

DRAWING NO.

# 7-B

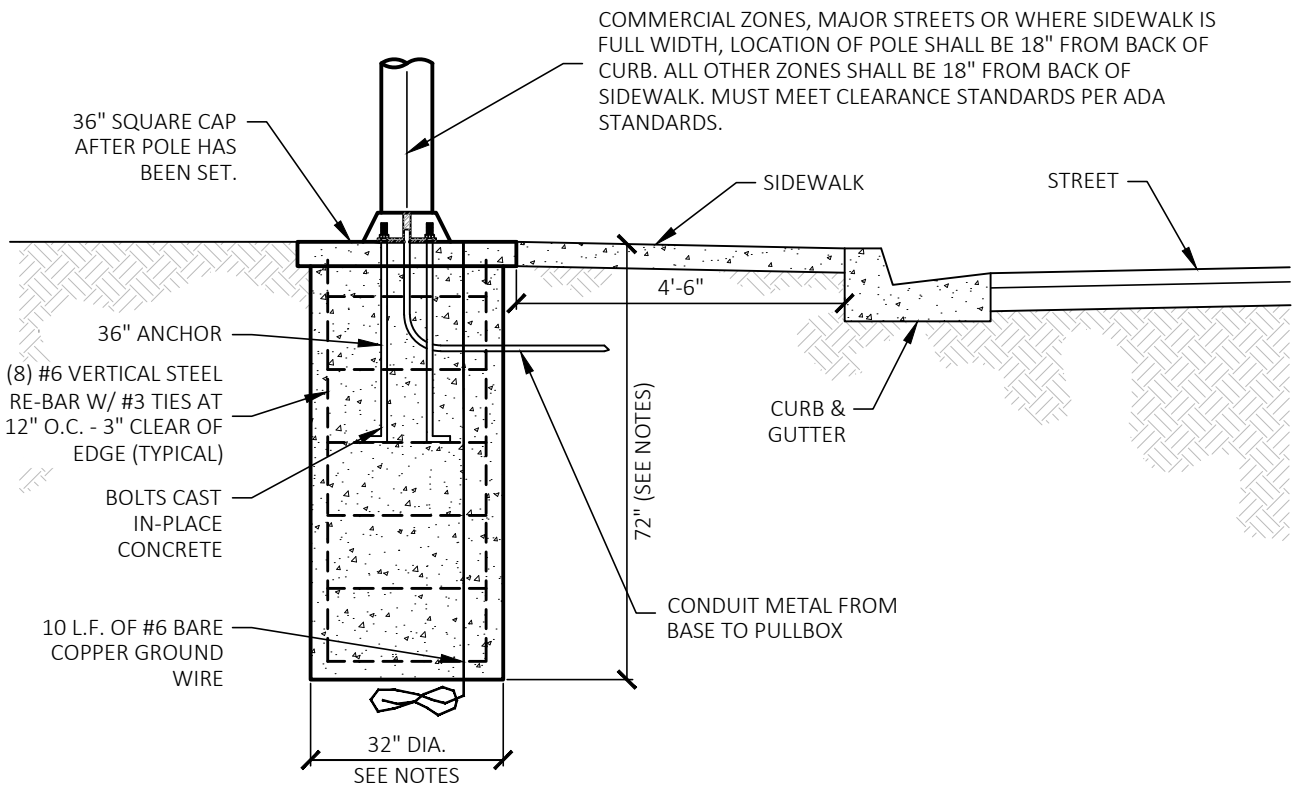

NOTES:

1. TYPICAL FOR 25' AND 28' POLES.
2. FOUNDATIONS MAY BE 36" SQUARE AND 60" DEEP.
3. CONCRETE TO BE PLACED AGAINST UNDISTURBED EARTH.

APPROVED BY CITY COUNCIL:  
RESOLUTION: 2025-094

*Rob Marler*

ROB MARLER, P.E. - CITY ENGINEER

# POLE FOUNDATION

CITY OF OAKDALE  
DEPARTMENT OF PUBLIC SERVICES

DATE: 09-15-25

DRAWING NO.

# 8-A

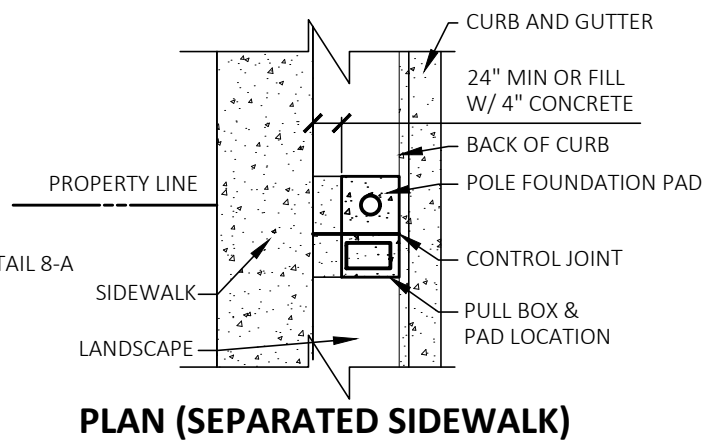
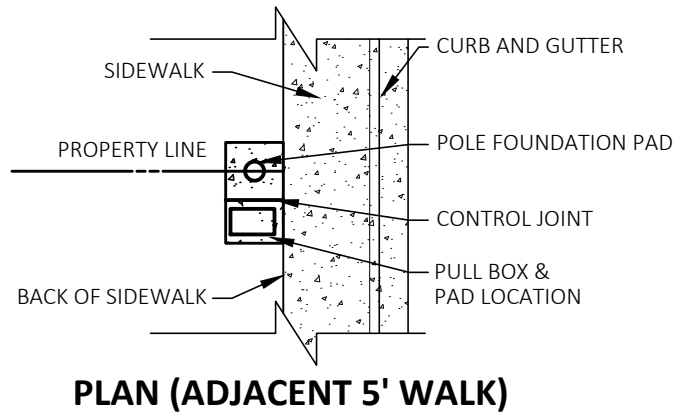
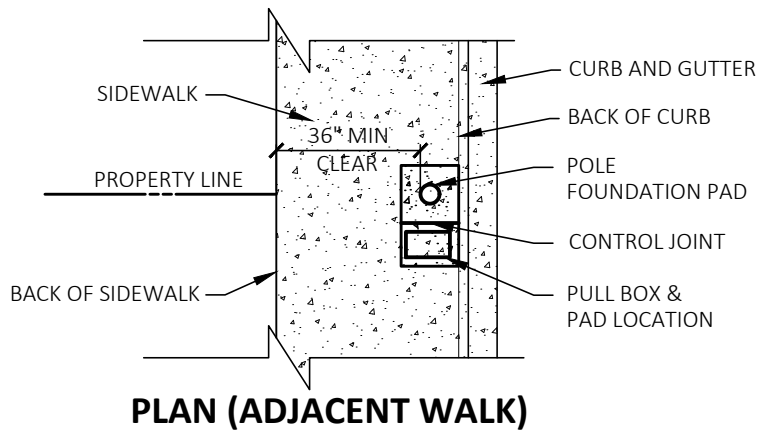
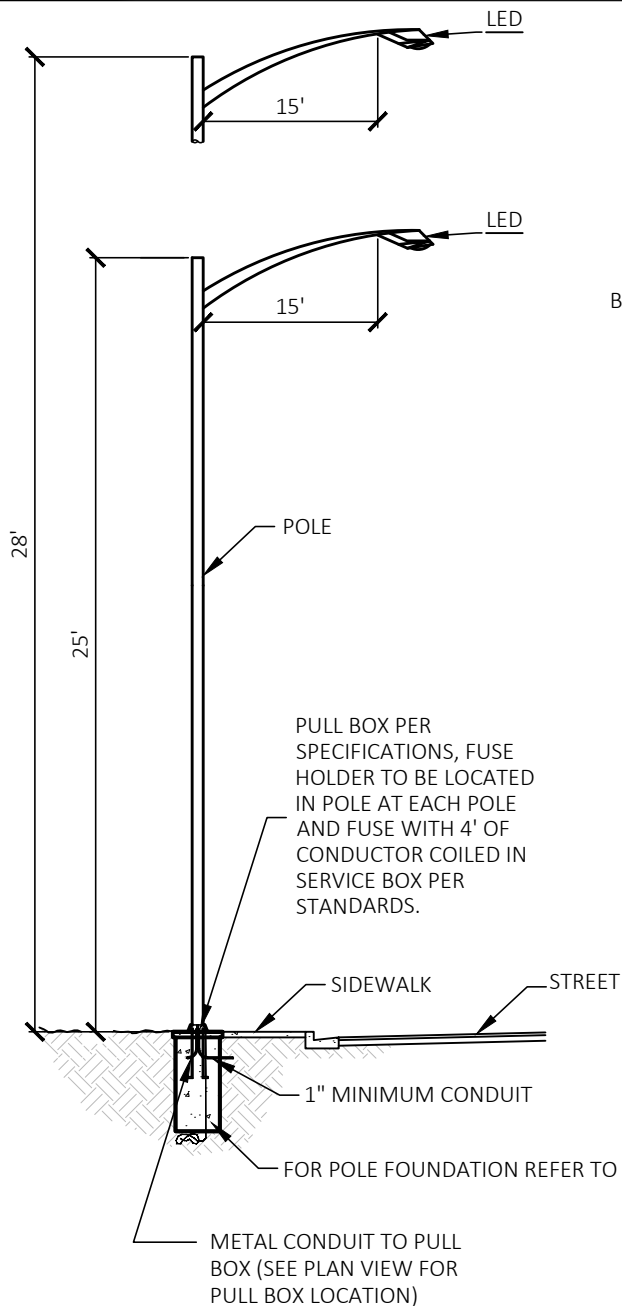

NOTES:

1. LUMINAIRES SHALL BE 120V OR AS DIRECTED BY THE ENGINEER, WITH BUILT-IN PHOTOELECTRIC CELLS.
2. LUMINAIRE TYPE AND SIZE SHALL BE LED, REFER TO SECTION 8.9 FOR CITY APPROVED AND ACCEPTABLE LED SIZING AND FIXTURES.
3. THE UTILITY PROVIDER WILL COMPLETE CONNECTION OF 120V CIRCUIT UPON RECEIPT OF SIGNED APPLICATION FOR SERVICE FROM THE CITY OF OAKDALE.
4. MINIMUM CONDUIT COVER: 30" IN STREETS, ALLEYS AND EASEMENTS, AND 18" IN PARK STRIP.
5. CONDUIT IN POLES SHALL BE WITHIN 3" BELOW THE BOTTOM OF HANDHOLES.
6. CONTACT THE UTILITY PROVIDER PRIOR TO ENTERING UNDERGROUND SERVICE BOX.

APPROVED BY CITY COUNCIL:  
RESOLUTION: 2025-094

*Rob Marler*

ROB MARLER, P.E. - CITY ENGINEER

**INSTALLATION LAYOUT**

CITY OF OAKDALE  
DEPARTMENT OF PUBLIC SERVICES

DATE: 09-15-25

DRAWING NO.

**8-B**

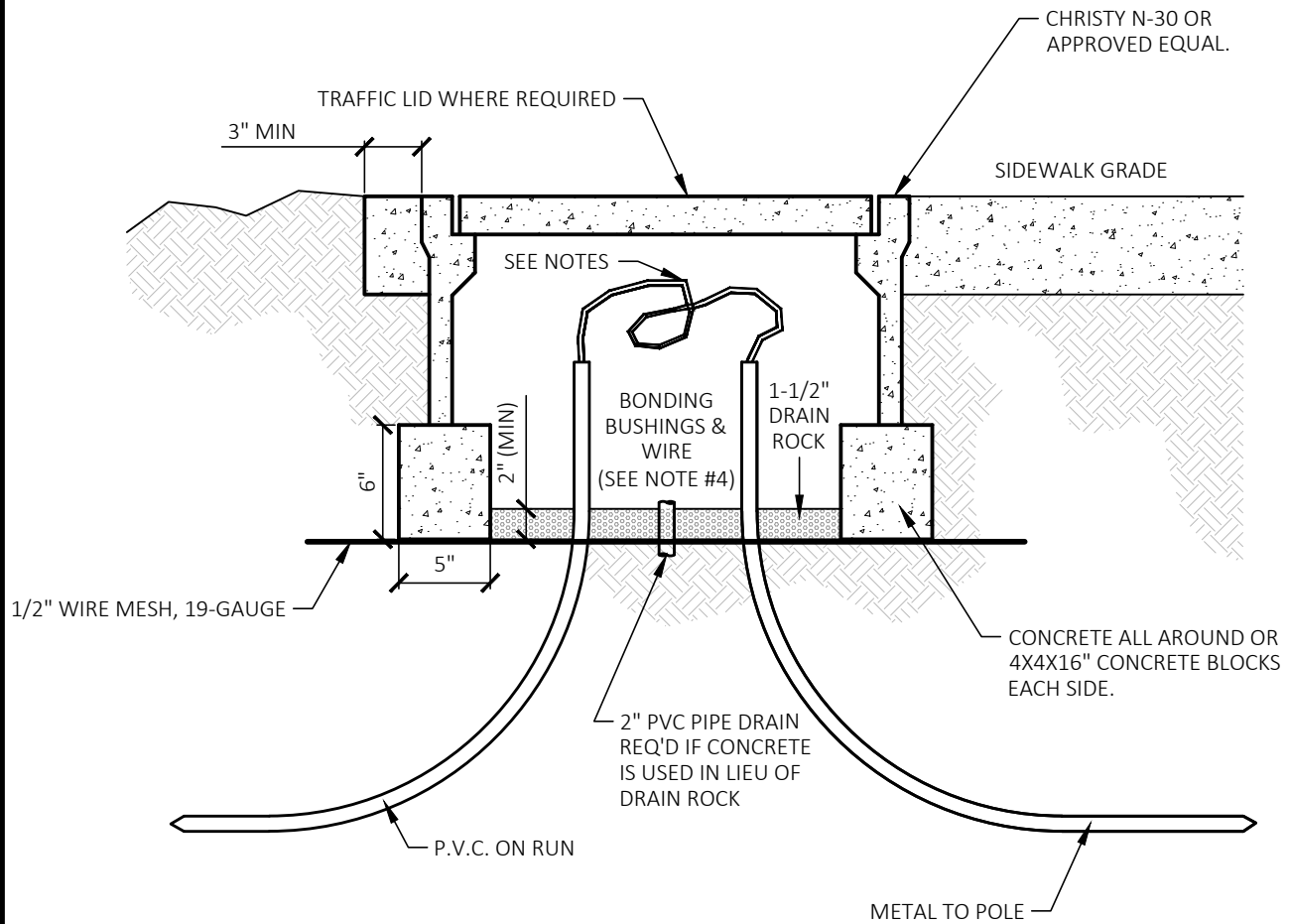

NOTES:

1. IF BOX IS MID-CIRCUIT, LEAVE 4' OF SLACK CONDUCTOR IN BOX.
2. IF BOX IS A CIRCUIT TERMINUS AT POWER SOURCE, INSTALL FUSE HOLDER IN POLE (PER SPECS.) WITH 4' OF SLACK CONDUCTOR. TAPE FUSE TO CONDUCTOR IN BOX.
3. CONDUIT ENTERING P.G.&E. OR UTILITY SERVICE BOX SHALL CONFORM TO SPECIFICATIONS.
4. THE BONDING WIRE SHALL BE AT LEAST THE SAME GAUGE AS THE LARGEST CIRCUIT CONDUCTOR. (MIN. 8 AWG COPPER WIRE). CHECK WITH THE UTILTIY PROVIDER.

APPROVED BY CITY COUNCIL:  
RESOLUTION: 2025-094

*Rob Marler*

ROB MARLER, P.E. - CITY ENGINEER

# PULL BOX

CITY OF OAKDALE  
DEPARTMENT OF PUBLIC SERVICES

DATE: 09-15-25

DRAWING NO.

# 8-C

**IN PARK STRIP OR EASEMENT**

**IN STREET OR ALLEY**

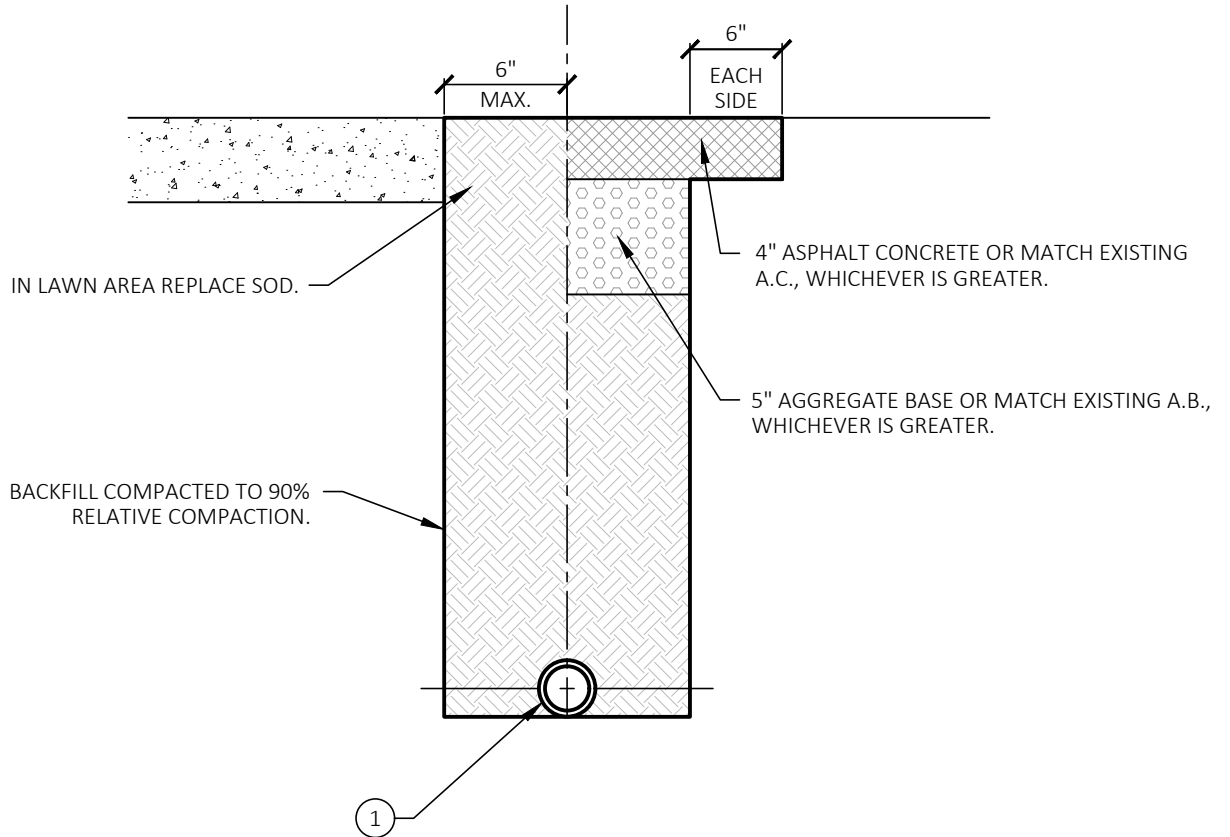

NOTES:

1. CONDUIT SHALL BE A MINIMUM DEPTH OF 18" BELOW SIDEWALK GRADE IN PARK STRIPS, AND 30" BELOW TOP OF CURB GRADE IN STREETS, ALLEYS AND EASEMENTS NOT ADJACENT TO CURB OR SIDEWALK. DEPTH SHALL NOT EXCEED 48". NOTE: CONDUIT MAY BE INSTALLED AT DEPTHS LESS THAN 30" IN STREETS, ALLEYS AND EASEMENTS WITH PRIOR, WRITTEN APPROVAL OF THE ENGINEER. SUCH APPROVAL MAY BE GRANTED ONLY UPON SPECIFIC REQUEST FROM THE DEVELOPER OR CITY CONTRACTOR. CONCRETE-ENCASED PVC CONDUIT MAY ALSO BE APPROVED UPON SPECIAL REQUEST.
2. COMMERCIAL: THE CONDUIT SHALL BE PLACED 6" BACK OF CURB.

APPROVED BY CITY COUNCIL:  
RESOLUTION: 2025-094

*Rob Marler*

ROB MARLER, P.E. - CITY ENGINEER

**DRY UTILITY  
TRENCH SECTION**

CITY OF OAKDALE  
DEPARTMENT OF PUBLIC SERVICES

DATE: 09-15-25

DRAWING NO.

**8-D**

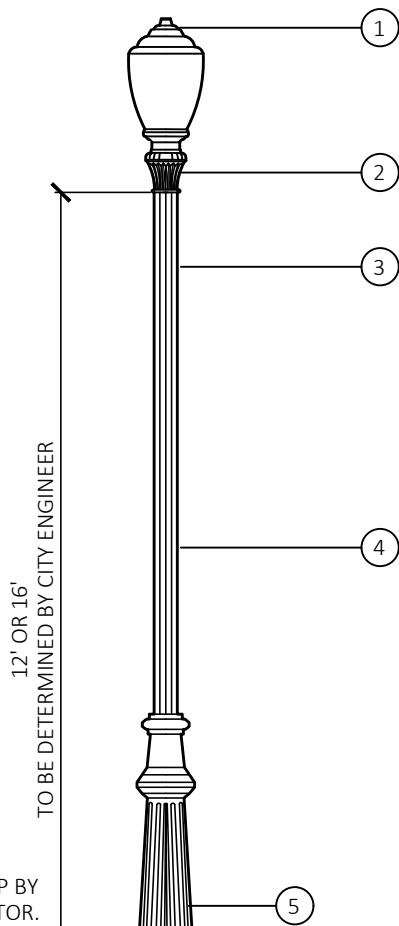

PHILLIPS HADCO RL54 POST TOP LUMINAIRE

CATALOG NO: RL54HANN2ANN64AN  
 POLE LENGTH: 12' OR 16'  
 POST TOP DIAMETER: 3" O.D.  
 PEDESTAL WIDTH: 12-3/4" SQ.  
 PEDESTAL HEIGHT: 43-3/4"  
 COLOR: BLACK

LUMINAIRE

MODEL: RL 54 GX3  
 WATTAGE: 51-68  
 LAMP STYLE: 64 LEDS  
 VOLTAGE 120-270

PART LIST

- ① ROOF - VICTORIAN
- ② FITTER / POD - ROUND CONTEMPORARY
- ③ GFI DUPLEX OULTET 12" DOWN FROM TOP
- ④ 4" DIA STRAIGHT FLUTED WITH 3" DIA TENON TOP O. D.
- ⑤ PHILLIPS P2560 BASE COVER

BALANCE OF 4" BASE CAP BY  
 SIDEWALK CONTRACTOR.  
 CONCRETE SHALL HAVE A BROOM  
 FINISH. CLASS "B" CONCRETE.

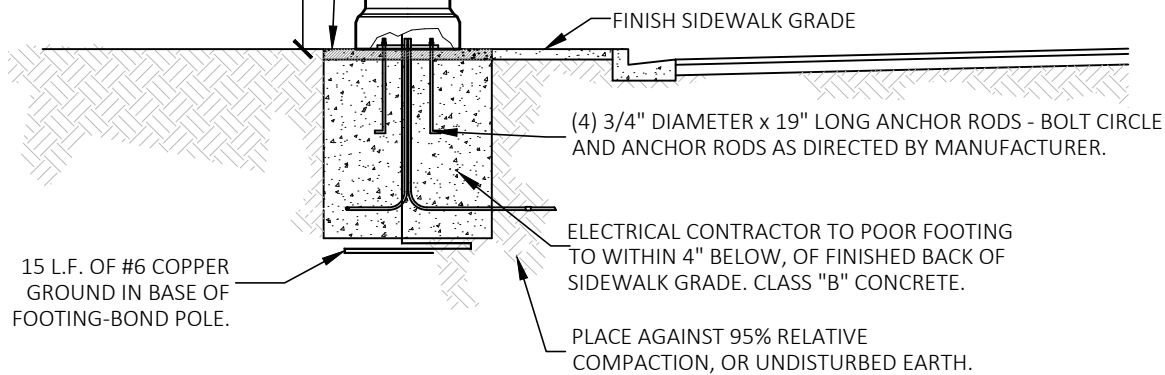

NOTES:

- 1. FUSE MUST BE LOCATED IN POLE.
- 2. DECORATIVE LIGHTS LOCATED IN RESIDENTIAL NEIGHBORHOODS DO NOT REQUIRE A GFI DUPLEX OUTLET.

APPROVED BY CITY COUNCIL:  
 RESOLUTION: 2025-094

*Rob Marler*

ROB MARLER, P.E. - CITY ENGINEER

**DECORATIVE LIGHT**

CITY OF OAKDALE  
 DEPARTMENT OF PUBLIC SERVICES

DATE: 09-15-25

DRAWING NO.

**8-E**

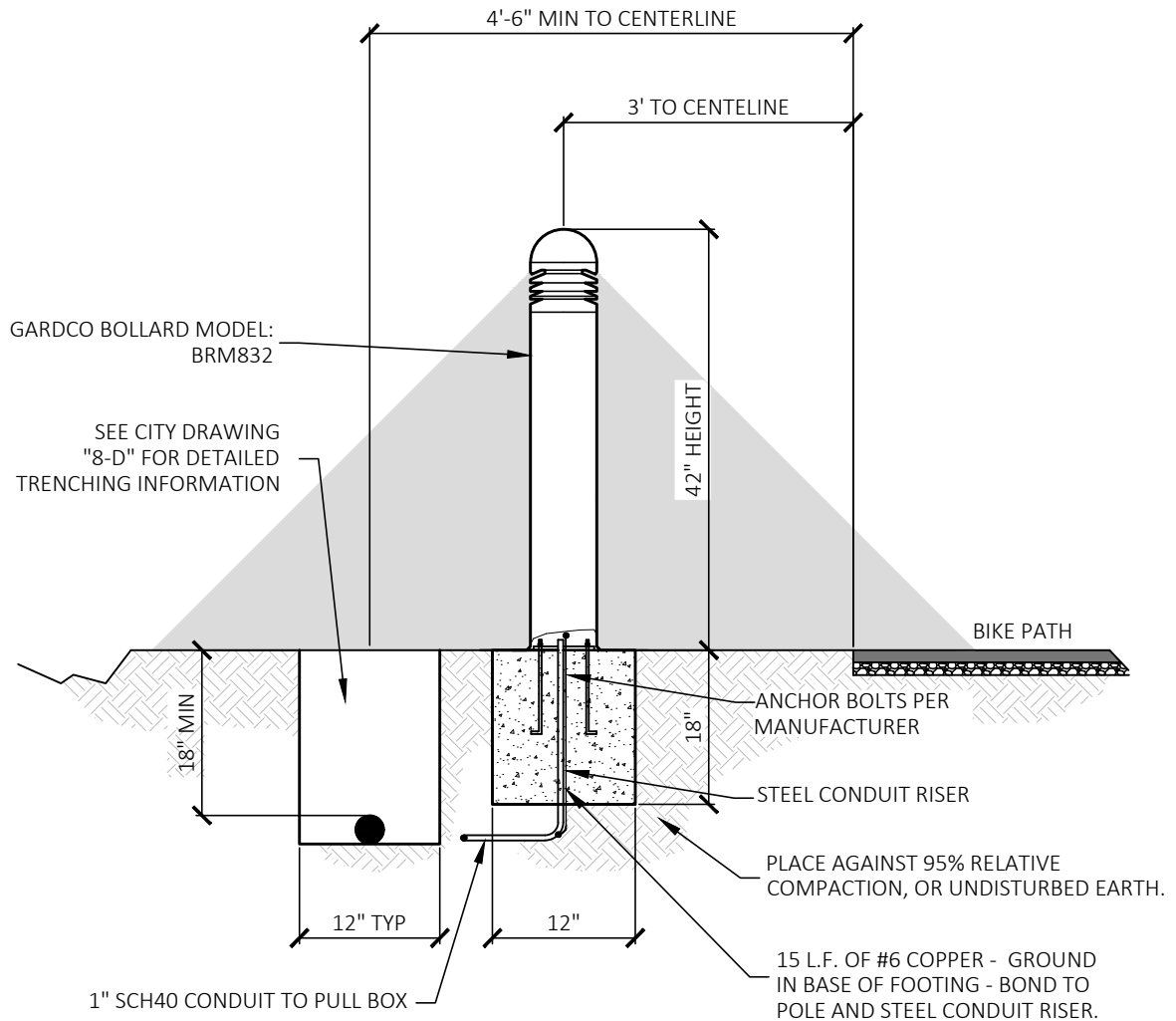

NOTES:

1. FUSE MUST BE LOCATED IN BOLLARD.
2. ANY CONDUCTIVE OBJECT INSTALLED WITHIN SIX FEET OF BOLLARD MUST BE BONDED TO BOLLARD GROUNDING SYSTEM.
3. BOLLARDS SHALL BE POWERED FROM A METER PANEL. GROUNDING SHALL EXTEND TO THE PANEL

APPROVED BY CITY COUNCIL:  
RESOLUTION: 2025-094

*Rob Marler*

ROB MARLER, P.E. - CITY ENGINEER

# LIGHTED BOLLARD

CITY OF OAKDALE  
DEPARTMENT OF PUBLIC SERVICES

DATE: 09-15-25

DRAWING NO.

# 8-F

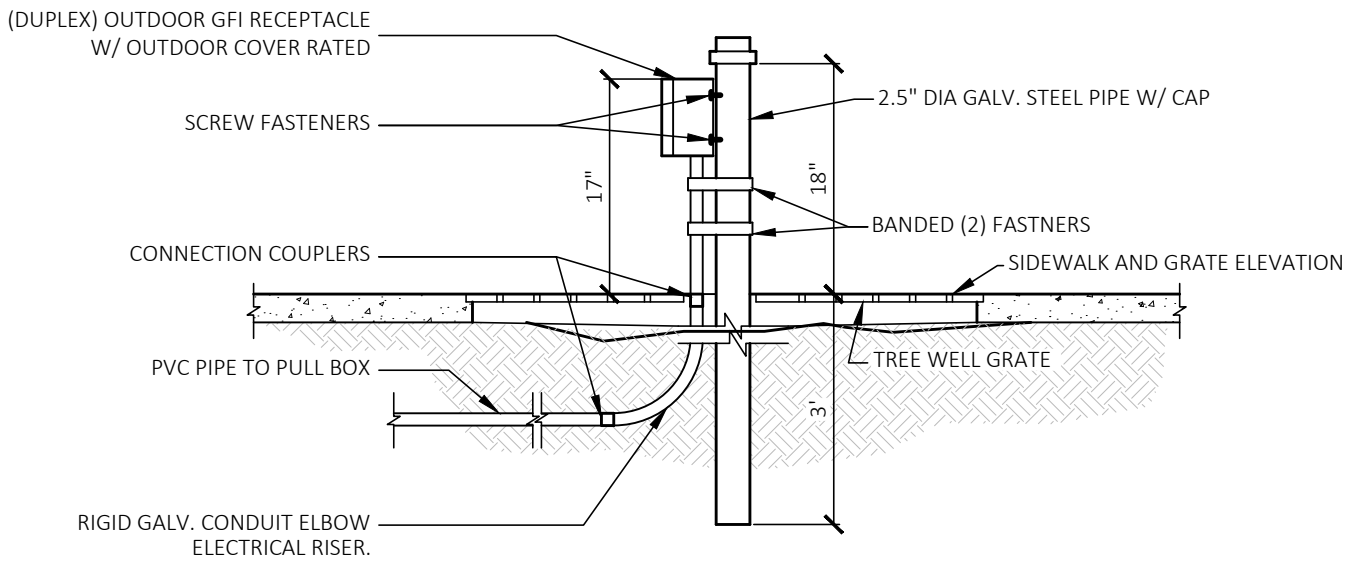
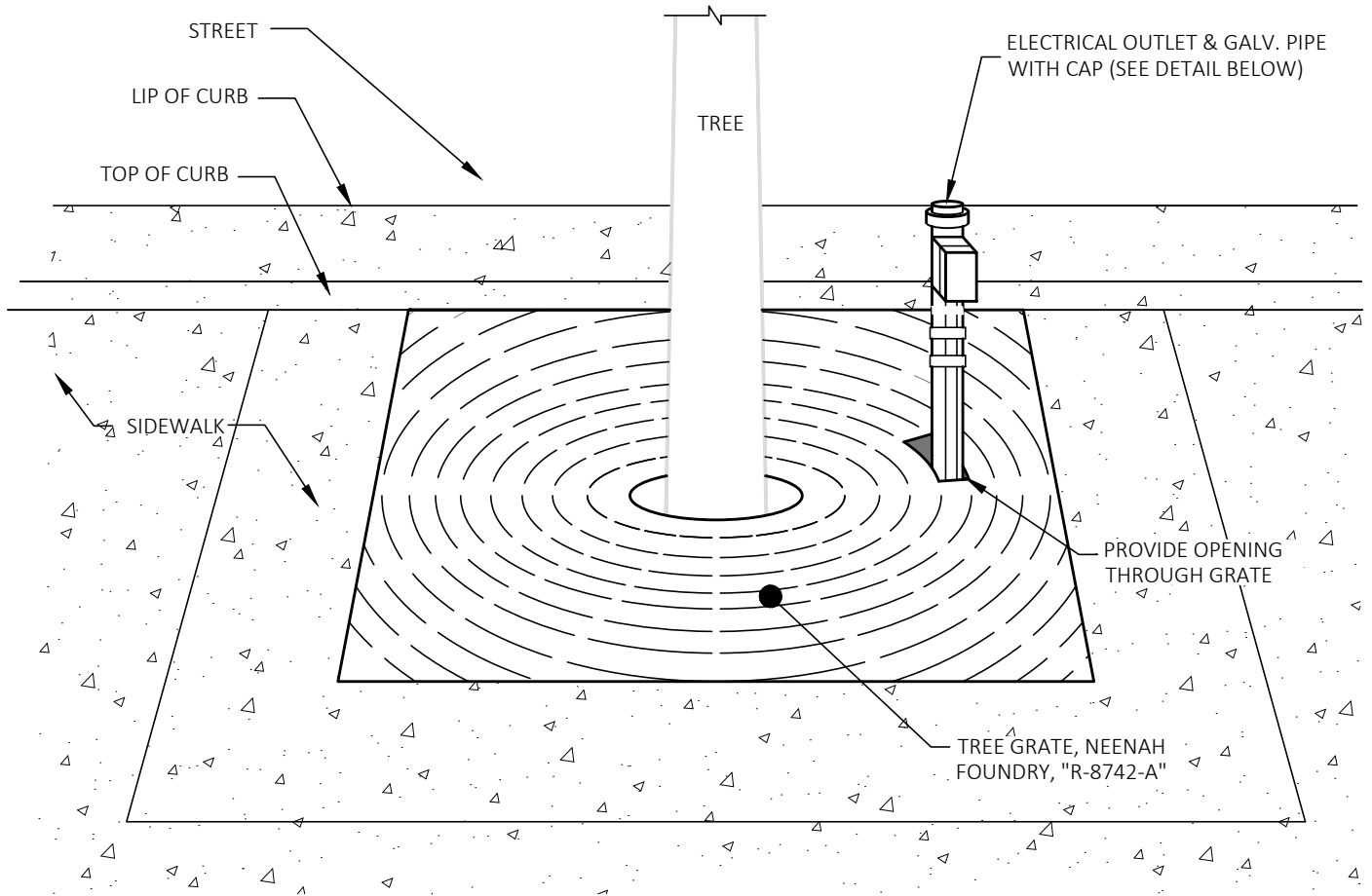

NOTES:

1. OUTLETS SHALL BE PLACED ON BACK OF TREE, ON OPPOSITE SIDE OF TREE FROM THE CURB OR A MINIMUM OF 18" DIAMETER OF CONCRETE FROM GRADE TO BOTTOM OF 2.5" GALVANIZED STEEL PIPE.

APPROVED BY CITY COUNCIL:  
RESOLUTION: 2025-094

*Rob Marler*

ROB MARLER, P.E. - CITY ENGINEER

# TREE WELL ELECTRICAL OUTLETS

CITY OF OAKDALE  
DEPARTMENT OF PUBLIC SERVICES

DATE: 09-15-25

DRAWING NO.

# 8-G



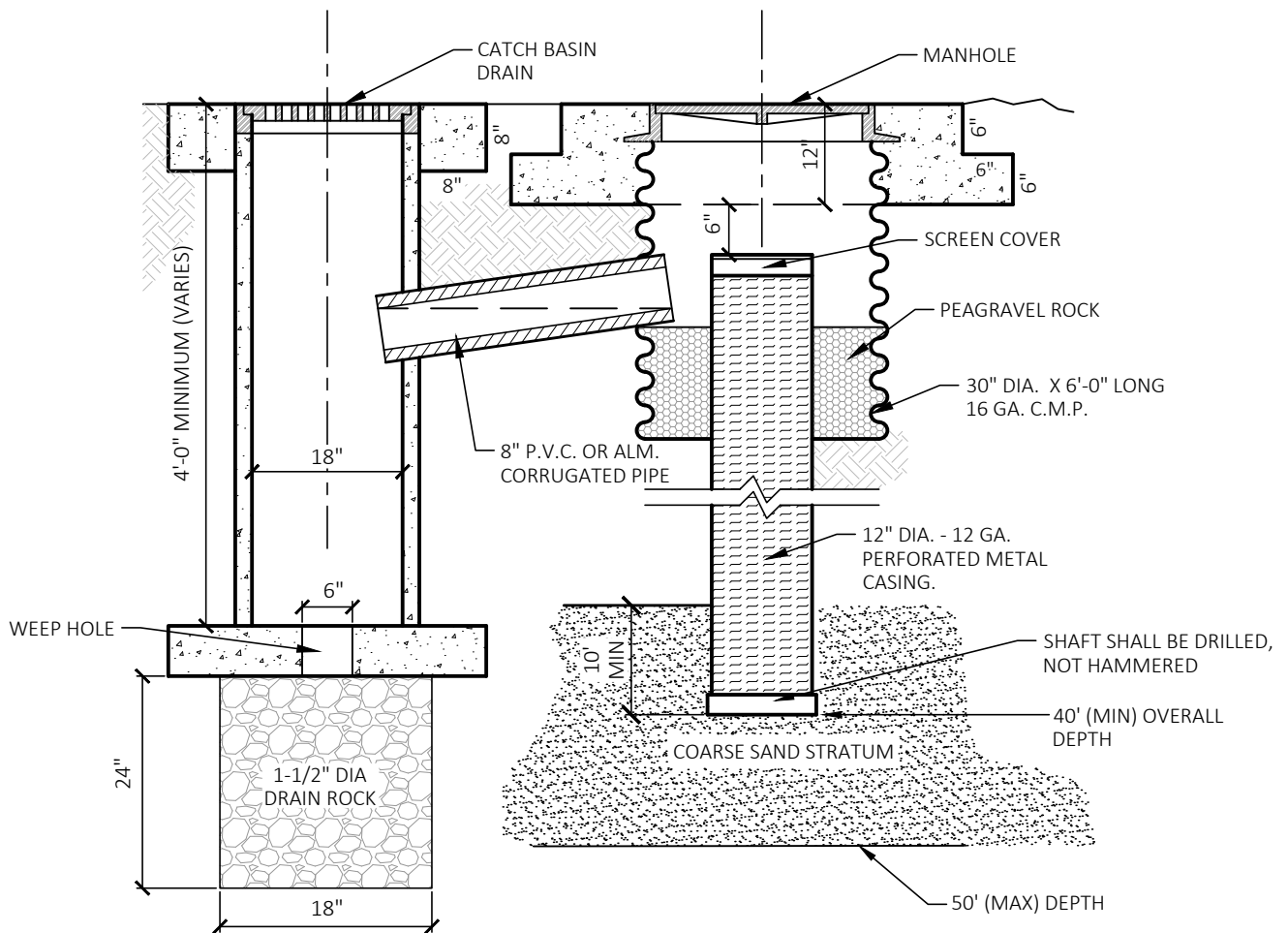
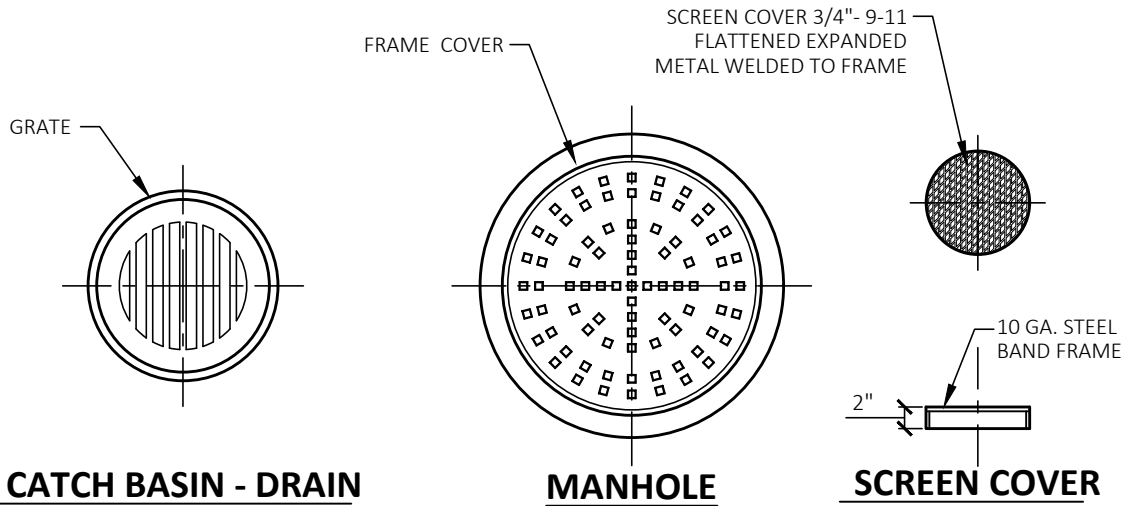

NOTES: SCREEN COVER

1. (13" I.D. FOR 12" CASING)
2. UNIT TO BE HOT DIPPED GALVANIZED AFTER MANUFACTURE.

APPROVED BY CITY COUNCIL:  
RESOLUTION: 2025-094

*Rob Marler*

ROB MARLER, P.E. - CITY ENGINEER

# ON-SITE DRYWELL

CITY OF OAKDALE  
DEPARTMENT OF PUBLIC SERVICES

DATE: 09-15-25

DRAWING NO.

# 10-B

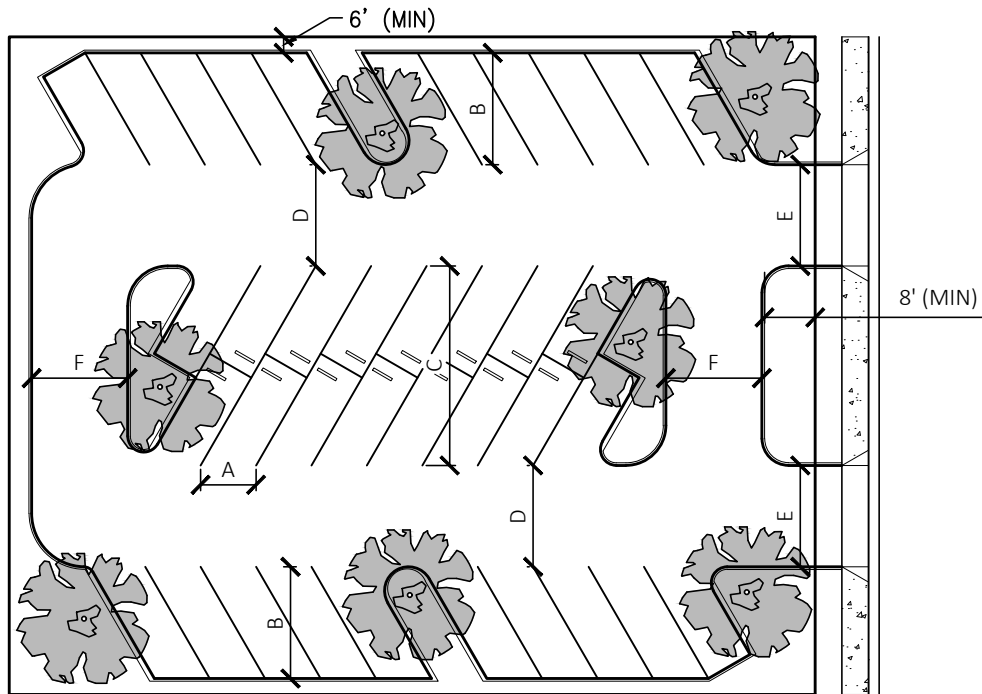

PARKING ANGLE		45°	50°	55°	60°	70°	80°	90°
A. STALL WIDTH	A.	12.7'	11.8'	11.0'	10.4'	9.6'	9.1'	9.0'
B. STALL DEPTH	B.	20.5'	21.1'	21.6'	21.8'	21.9'	21.3'	20.0'
C. DOUBLE STALL DEPTH	C.	34.7'	36.4'	37.9'	39.1'	40.7'	41.0'	40'
D. AISLE WIDTH	D.	13.0'	15.0'	17.0'	19.0'	23.0'	27.0'	31.0'
E. DRIVEWAY WIDTH	E.	SEE NOTE 4						
F. TURNAROUND	F.	SEE NOTE 5						

NOTES:

1. EACH OFF-STREET PARKING STALL SHALL CONTAIN A RECTANGULAR AREA WITH A MINIMUM WIDTH OF 9' AND A MINIMUM LENGTH OF 20'.
2. A MAXIMUM OF 30% OF REQUIRED STALLS MAY BE DESIGNATED FOR COMPACT CARS. COMPACT CAR STALLS SHALL CONTAIN A RECTANGULAR AREA WITH A MINIMUM WIDTH OF 7.5' AND A MINIMUM LENGTH OF 15'.
3. PARKING AREAS SHALL BE PAVED WITH A MINIMUM OF 2" AC AND SHALL BE GRADED AND DESIGNED TO DISPOSE OF ALL SURFACE WATER AS APPROVED BY THE CITY ENGINEER.
4. ANY DRIVEWAY USED FOR BOTH INGRESS AND EGRESS TO AND FROM A PARKING LOT AND NOT DIRECTLY SERVING PARKING STALLS SHALL HAVE A MINIMUM WIDTH OF 20'. ANY DRIVEWAY USED ONLY FOR EITHER INGRESS OR EGRESS TO OR FROM A PARKING LOT AND NOT DIRECTLY SERVING PARKING STALLS SHALL BE A MINIMUM OF 10' IN WIDTH. ALL DRIVEWAYS CONNECTING PUBLIC RIGHTS-OF-WAY TO OFF-STREET PARKING LOTS SHALL COMPLY WITH CITY OF OAKDALE REQUIREMENTS.
5. TURNAROUNDS SHALL BE A MINIMUM OF 18' WIDE.
6. ALL PARKING AREAS OF 5 OR MORE STALLS SHALL BE MARKED BY EITHER STRIPING OR BUTTONS TO DELINEATE SPACES.
7. ALL PARKING AREAS OF 10 OR MORE SPACES SHALL BE LANDSCAPED. THERE SHALL BE ONE DECIDUOUS SHADE TREE PLANTED FOR EACH 10 STALLS. THE TREES SHALL BE DISTRIBUTED THROUGHOUT THE AREA TO SHADE SPACES ON AS UNIFORM A BASIS AS PRACTICAL. FOR PARKING AREAS WITH ONLY ONE AISLE THE TREES MAY BE PLANTED ALONG THE PERIPHERY.
8. FOR ANY GIVEN PARKING ANGLE BETWEEN 45° AND 90° NOT SPECIFICALLY LISTED IN THE ABOVE TABLE, USE THE TABLE ANGLE NEAREST THE GIVEN ANGLE.
9. ALL VERTICAL CURB ADJACENT TO PARKING SPACES SHALL BE 12" WIDE, A.K.A COURTESY CURB.

APPROVED BY CITY COUNCIL:  
RESOLUTION: 2025-094

*Rob Marler*

ROB MARLER, P.E. - CITY ENGINEER

## PARKING LOT STANDARDS TYPICAL LAYOUT

CITY OF OAKDALE  
DEPARTMENT OF PUBLIC SERVICES

DATE: 09-15-25

DRAWING NO.

**10-C**

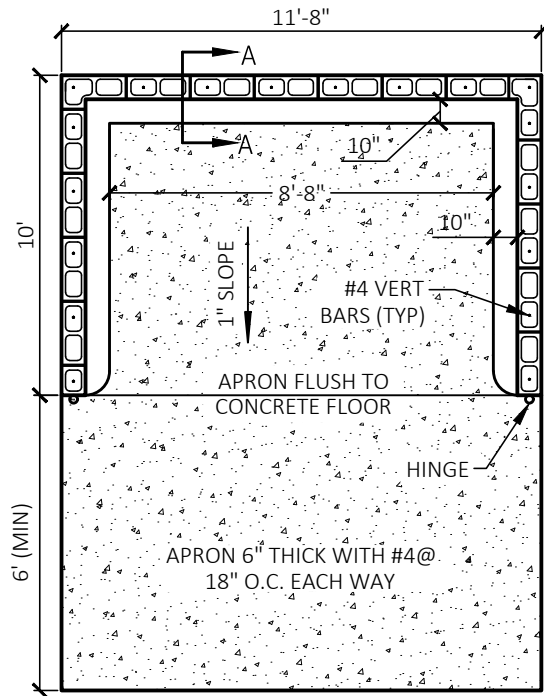

**PLAN VIEW**

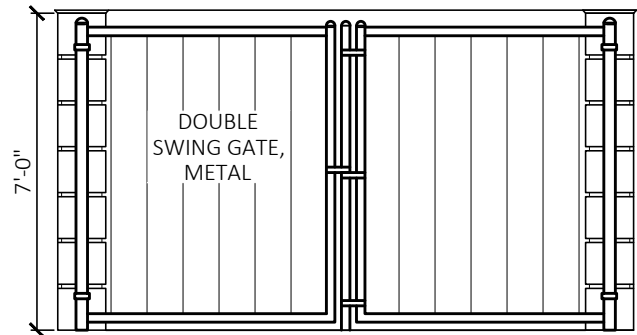

**FRONT ELEVATION**

PLACE A BAR STOP EQUAL TO DEPTH OF HOLE TO BOTTOM OF GATE

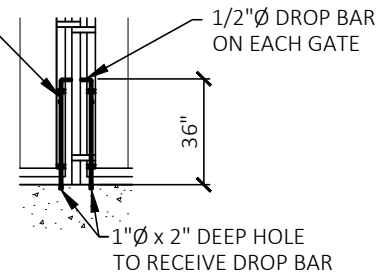

PROVIDE AN ADDITIONAL 1" Ø x 2" DEEP HOLE FOR EACH GATE IN CONCRETE APRON AT 95° OPEN

**CANE BOLT LATCH**

NOTES:

1. ALL CELLS IN CONCRETE BLOCKS SHALL BE FILLED SOLID WITH COARSE GROUT.
2. CORNER BLOCK ENDS AND CENTER WEB SHALL BE CUT TO FORM A CONTINUOUS BOND BEAM.
3. ALL HORIZONTAL AND VERTICAL JOINTS SHALL BE RAKED TO MATCH CENTER SCORED BLOCK.
4. CONCRETE BLOCK, MORTAR, AND COARSE GROUT SHALL CONFORM WITH APPLICABLE SECTION OF THE LATEST UNIFORM BUILDING CODE.
5. SLAB FLOOR AND FOOTING SHALL BE CLASS "B" PORTLAND CEMENT CONCRETE.
6. GROUND SHALL BE SLOPED AWAY FROM WALLS.
7. IF GATES ARE INSTALLED ON ENCLOSURE HINGES, THEY MUST BE ATTACHED IN FRONT RATHER THAN ON THE SIDE OF THE ENCLOSURE WALLS.
8. STRUCTURES MAY INCLUDE ARCHITECTURAL FEATURES COMPATIBLE WITH BUILDING ARCHITECTURE.

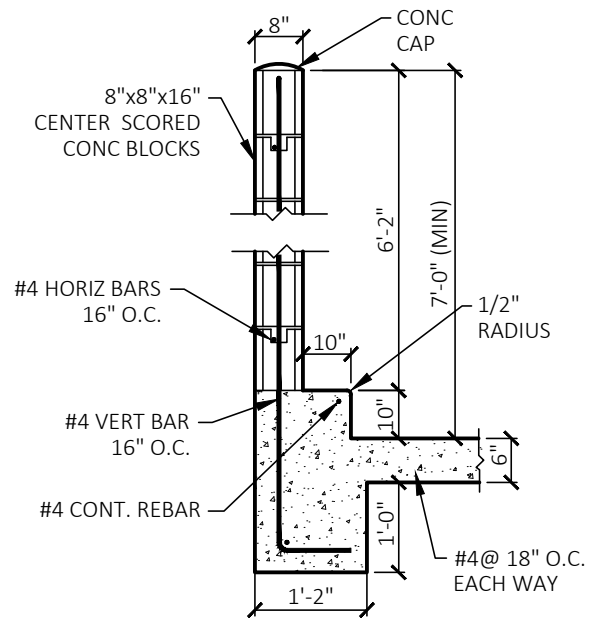

**SECTION A**

APPROVED BY CITY COUNCIL:  
RESOLUTION: 2025-094

*Rob Marler*

ROB MARLER, P.E. - CITY ENGINEER

**(SINGLE) CONCRETE BLOCK TRASH ENCLOSURE**

CITY OF OAKDALE  
DEPARTMENT OF PUBLIC SERVICES

DATE: 09-15-25

DRAWING NO.

**10-D**

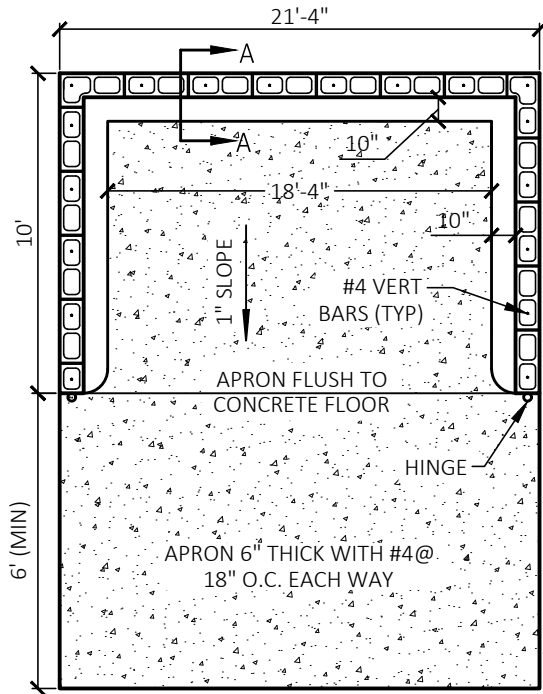

**PLAN VIEW**

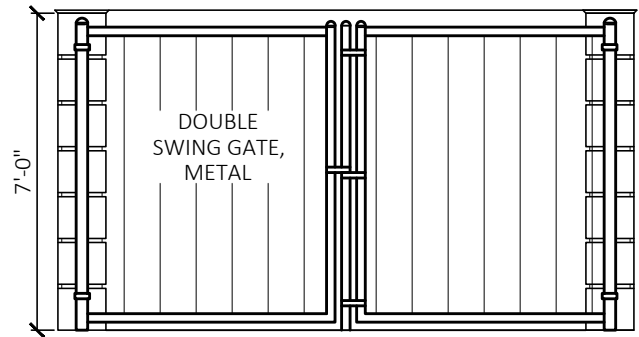

**FRONT ELEVATION**

PLACE A BAR STOP EQUAL TO DEPTH OF HOLE TO BOTTOM OF GATE

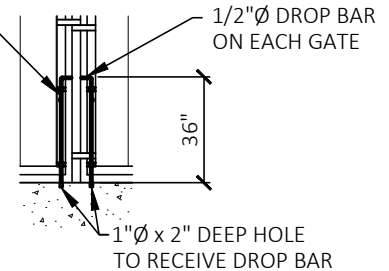

PROVIDE AN ADDITIONAL 1"Ø x 2" DEEP HOLE FOR EACH GATE IN CONCRETE APRON AT 95° OPEN

**CANE BOLT LATCH**

NOTES:

1. ALL CELLS IN CONCRETE BLOCKS SHALL BE FILLED SOLID WITH COARSE GROUT.
2. CORNER BLOCK ENDS AND CENTER WEB SHALL BE CUT TO FORM A CONTINUOUS BOND BEAM.
3. ALL HORIZONTAL AND VERTICAL JOINTS SHALL BE RAKED TO MATCH CENTER SCORED BLOCK.
4. CONCRETE BLOCK, MORTAR, AND COARSE GROUT SHALL CONFORM WITH APPLICABLE SECTION OF THE LATEST UNIFORM BUILDING CODE.
5. SLAB FLOOR AND FOOTING SHALL BE CLASS "B" PORTLAND CEMENT CONCRETE.
6. GROUND SHALL BE SLOPED AWAY FROM WALLS.
7. MULTIPLE BIN ENCLOSURES SHALL BE EVEN MULTIPLES OF TEN FEET IN WIDTH.
8. IF GATES ARE INSTALLED ON ENCLOSURE HINGES, THEY MUST BE ATTACHED IN FRONT RATHER THAN ON THE SIDE OF THE ENCLOSURE WALLS.
9. STRUCTURES MAY INCLUDE ARCHITECTURAL FEATURES COMPATIBLE WITH BUILDING ARCHITECTURE.

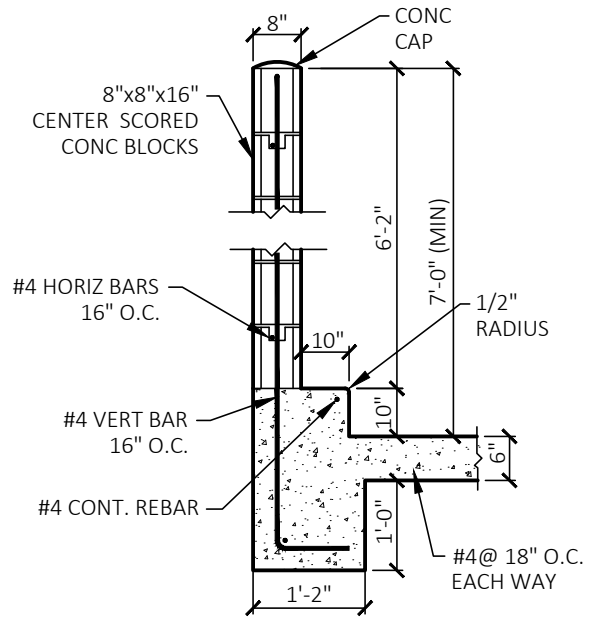

**SECTION A**

APPROVED BY CITY COUNCIL:  
RESOLUTION: 2025-094

*Rob Marler*

ROB MARLER, P.E. - CITY ENGINEER

**(DOUBLE) CONCRETE BLOCK TRASH ENCLOSURE**

CITY OF OAKDALE  
DEPARTMENT OF PUBLIC SERVICES

DATE: 09-15-25

DRAWING NO.

**10-E**



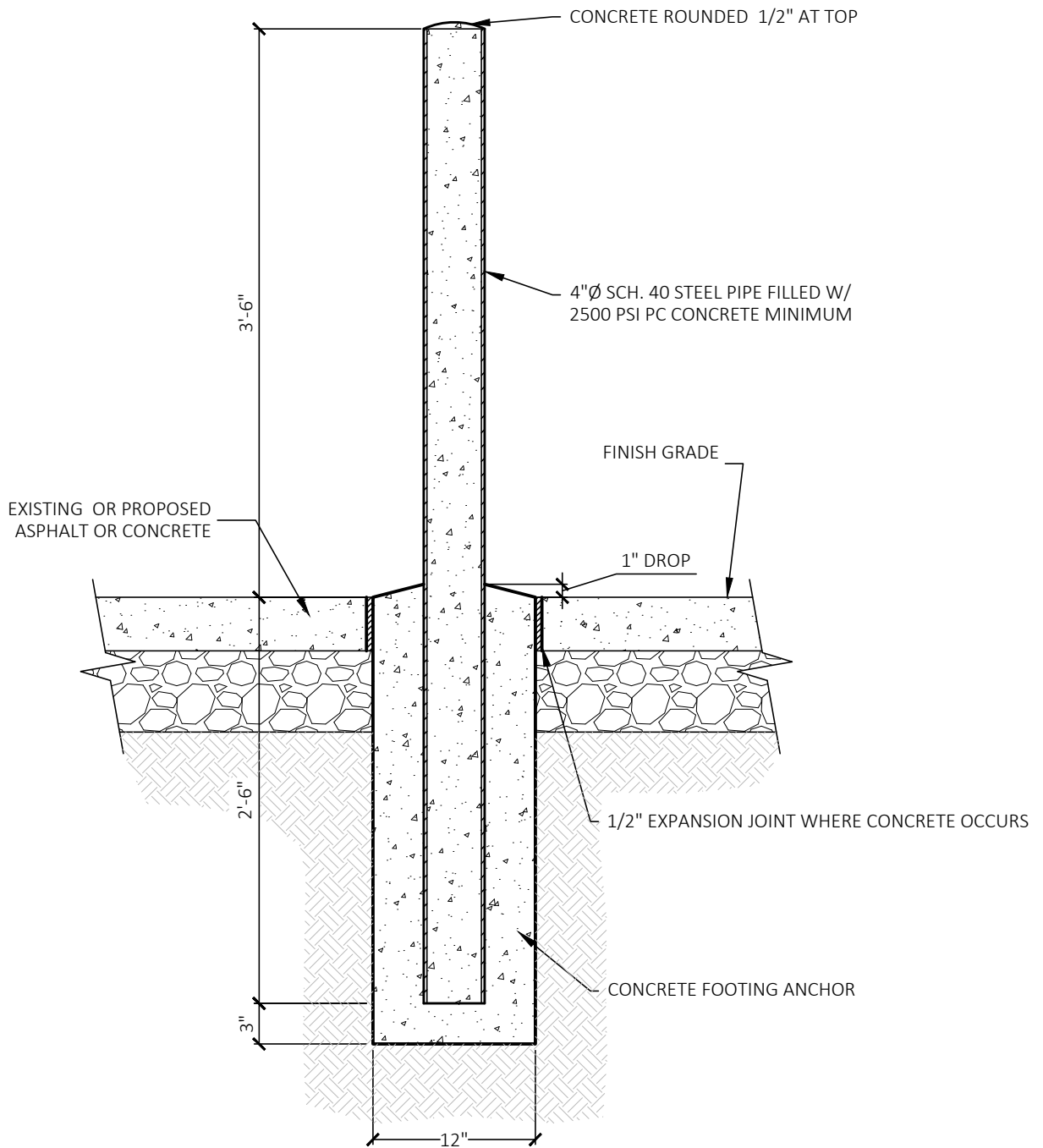

NOTES:

1. ALL PIPES SHALL BE PAINTED TRAFFIC YELLOW.

APPROVED BY CITY COUNCIL:  
RESOLUTION: 2025-094

*Rob Marler*

ROB MARLER, P.E. - CITY ENGINEER

## PIPE BOLLARD

CITY OF OAKDALE  
DEPARTMENT OF PUBLIC SERVICES

DATE: 09-15-25

DRAWING NO.

**10-G**

RECOMMENDED COMPONENTS:

- (2) 752 Phase Selectors - 2 Channels
- (4) 721 Detectors - 2 Barrels - 1 Channel
- (1) 560 Chassis - NEMA - 2 Cards
- (X) 138 Cable - By Installer

GENERAL INFORMATION:

Detectors should be placed to provide the best "line of sight," typically on the far mast arm and centered on the #1 lane in each direction of travel. 3M requires the installation of the 757 harness for advance detectors and the "green sensing" function. The 757 harness enables phase selectors to log all aspects of pre-emption. This data may be essential to defend an agency in the event of a liability law suit, caused an accident at a signalized intersection.

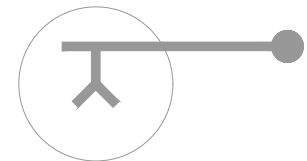

SYMBOL FOR 721 DETECTOR

APPROVED BY CITY COUNCIL:  
RESOLUTION: 2025-094

ROB MARLER, P.E. - CITY ENGINEER

# SINGLE LANE TRAFFIC

## 721 DETECTORS, 752 PHASE SELECTORS

CITY OF OAKDALE  
DEPARTMENT OF PUBLIC SERVICES

DATE: 09-15-25

DRAWING NO.

# 11-A

RECOMMENDED COMPONENTS:

- (2) 752 Phase Selectors - 2 Channels
- (4) 721 Detectors - 2 Barrels - 1 Channel

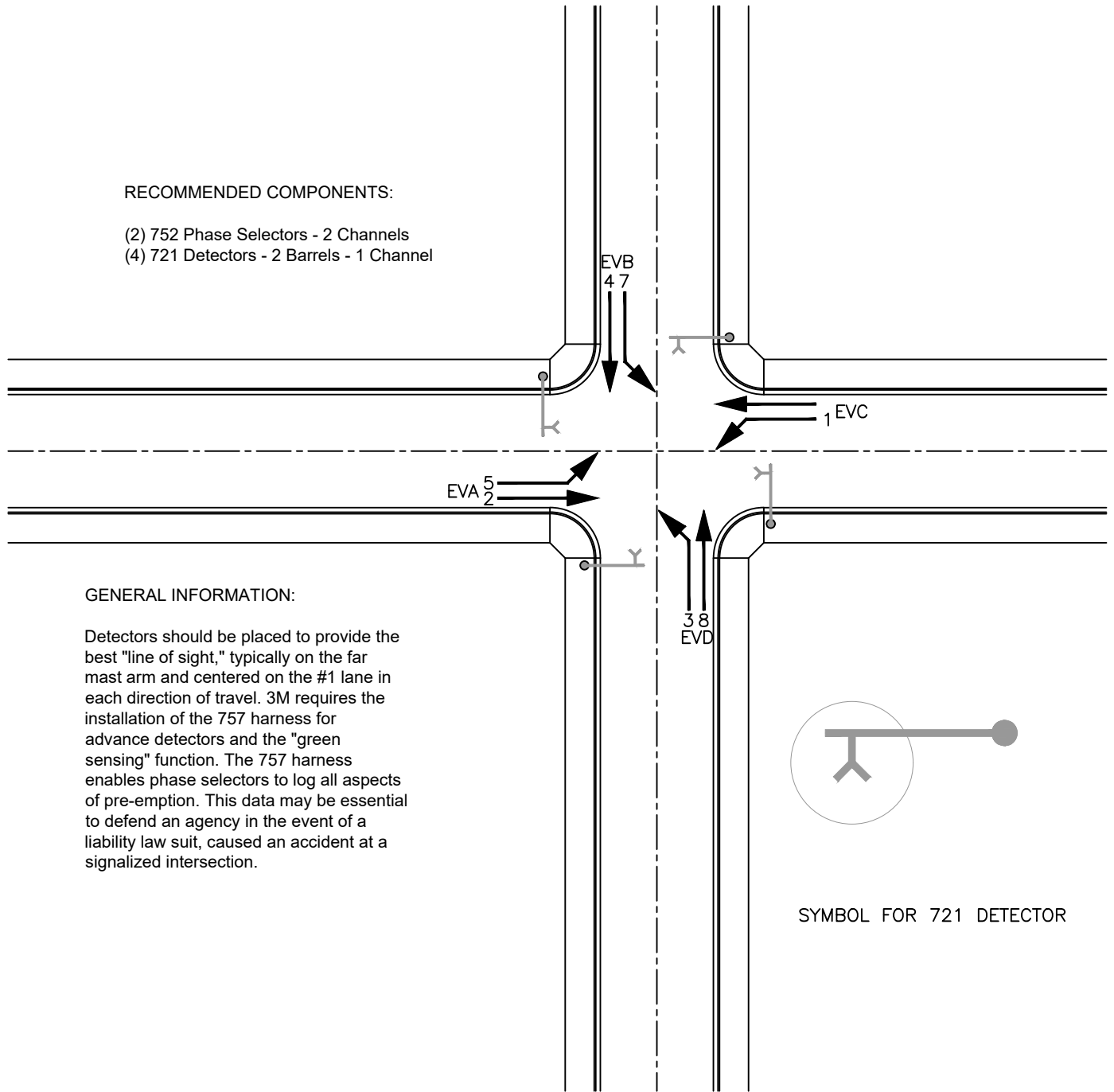

GENERAL INFORMATION:

Detectors should be placed to provide the best "line of sight," typically on the far mast arm and centered on the #1 lane in each direction of travel. 3M requires the installation of the 757 harness for advance detectors and the "green sensing" function. The 757 harness enables phase selectors to log all aspects of pre-emption. This data may be essential to defend an agency in the event of a liability law suit, caused an accident at a signalized intersection.

APPROVED BY CITY COUNCIL:  
 RESOLUTION: 2025-094

*Rob Marler*

ROB MARLER, P.E. - CITY ENGINEER

**MULTIPLE LANE TRAFFIC**  
**721 DETECTORS, 752 PHASE SELECTORS**

CITY OF OAKDALE  
 DEPARTMENT OF PUBLIC SERVICES

DATE: 09-15-25

DRAWING NO.  
**11-A-1**

OPTICOM PRIORITY CONTROL SYSTEMS

The 721 detects with 2 optic surfaces serving 1 channel and has up to a 16 Degree spread. The detection zone may be significantly reduced if placed in the manner below.

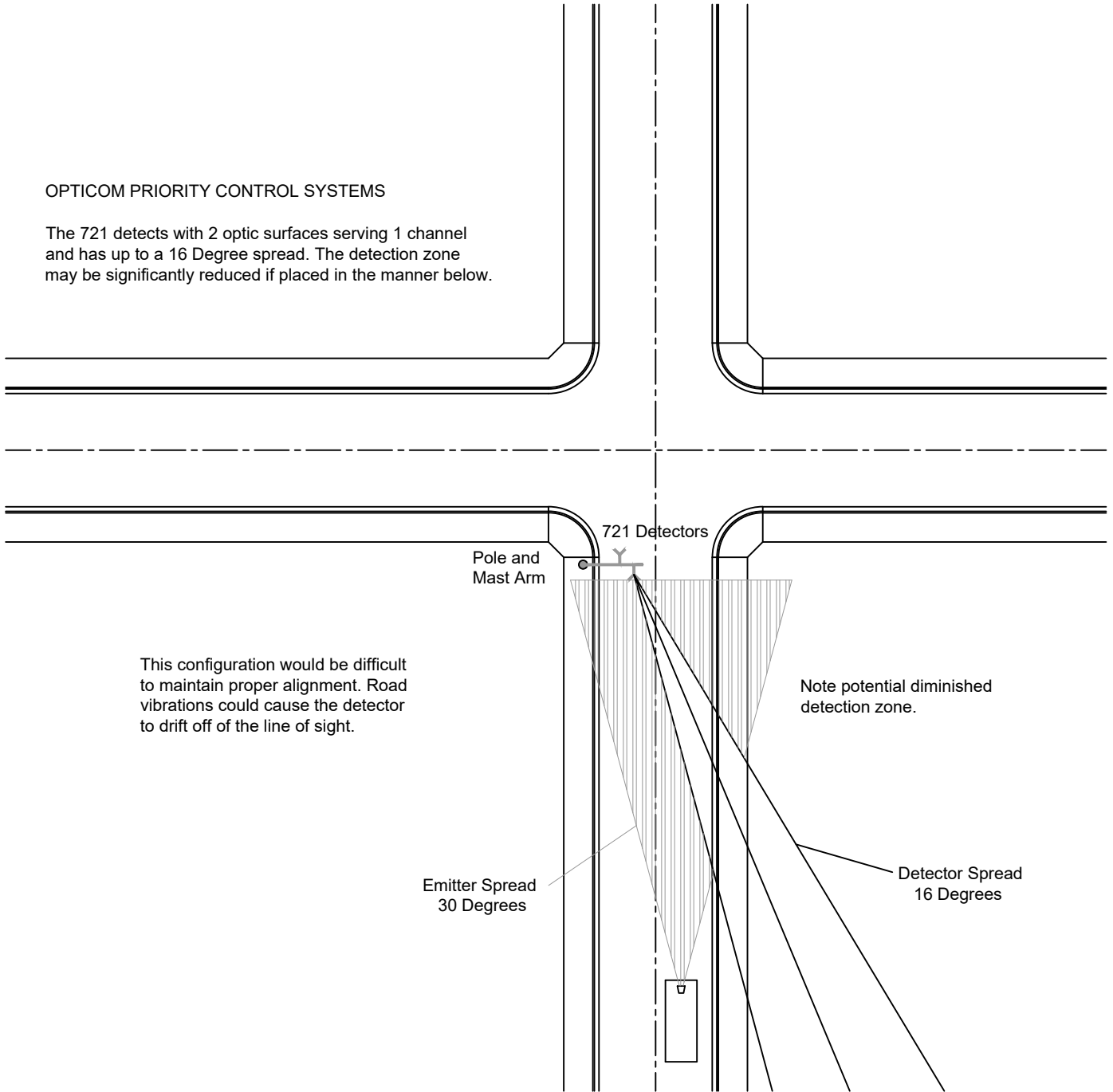

This configuration would be difficult to maintain proper alignment. Road vibrations could cause the detector to drift off of the line of sight.

Note potential diminished detection zone.

Emitter Spread  
30 Degrees

Detector Spread  
16 Degrees

APPROVED BY CITY COUNCIL:  
RESOLUTION: 2025-094

ROB MARLER, P.E. - CITY ENGINEER

# OPTICON PRIORITY CONTROL SYSTEMS

CITY OF OAKDALE  
DEPARTMENT OF PUBLIC SERVICES

DATE: 09-15-25

DRAWING NO.

# 11-A-2

SITE PLAN

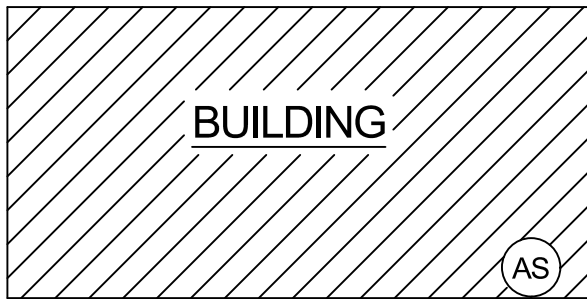

BUILDING ADDRESS

APPROVED BY CITY COUNCIL:  
RESOLUTION: 2025-094

ROB MARLER, P.E. - CITY ENGINEER

**REQUIREMENTS ON  
PRE-FIRE PLANS**

CITY OF OAKDALE  
DEPARTMENT OF PUBLIC SERVICES

DATE: 09-15-25

DRAWING NO.

**11-B**

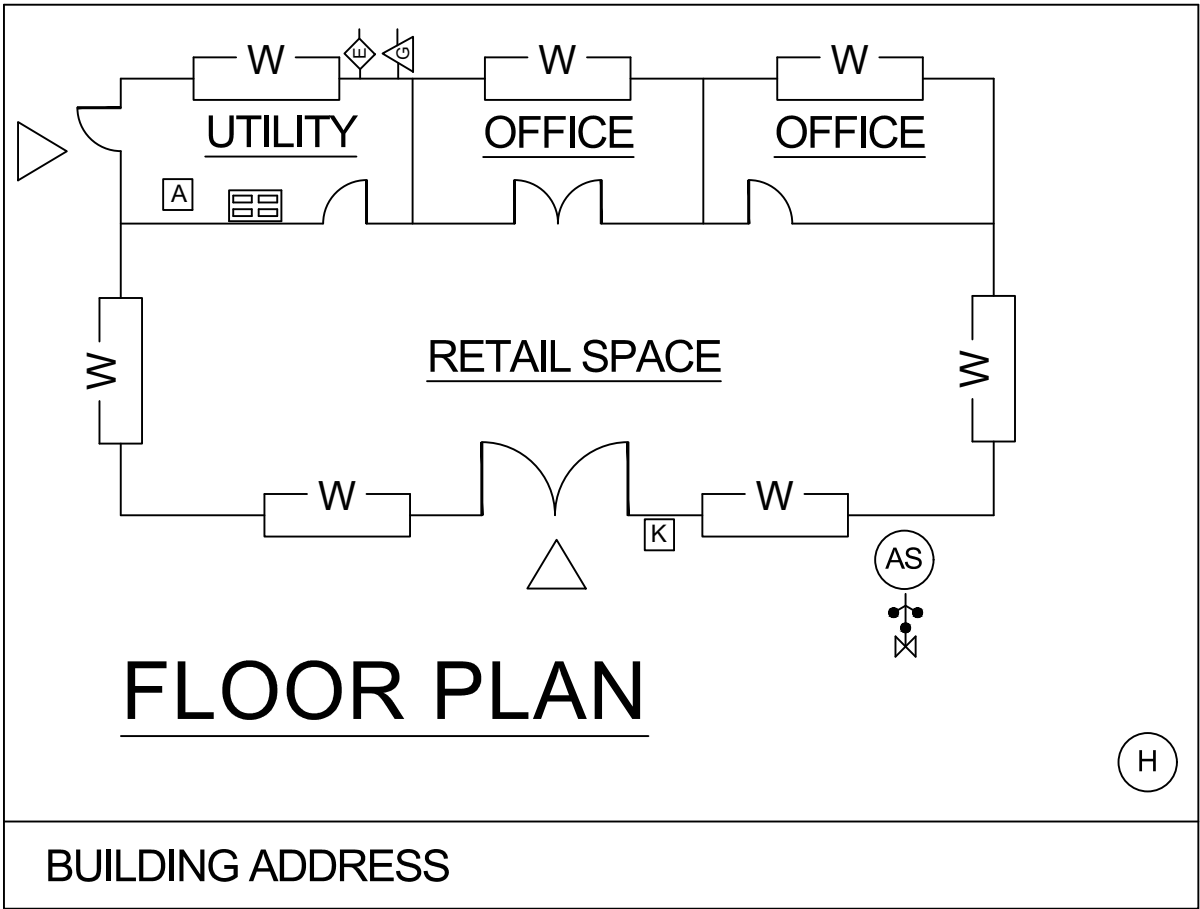

**FLOOR PLAN**

(H)

BUILDING ADDRESS

APPROVED BY CITY COUNCIL:  
RESOLUTION: 2025-094

*Rob Marler*

ROB MARLER, P.E. - CITY ENGINEER















**REQUIREMENTS ON  
PRE-FIRE PLANS**

CITY OF OAKDALE  
DEPARTMENT OF PUBLIC SERVICES

DATE: 09-15-25

DRAWING NO.

**11-B-1**

SYMBOLS	
	HYDRANT
	FDC
	FULLY SPRINKLERED
	PARTIALLY SPRINKLERED
	NON-SPRINKLERED
	FIRE ALARM PANEL FACP
	KNOX BOX
	GAS SHUT OFF
	ELECTRICAL SHUT OFF
	HAZARDOUS MATERIALS
	ACCESS F.D.
	POST INDICATOR VALVE
	FIRE EXTINGUISHERS
	ABOVE GROUND TANK
	ATTIC ACCESS

APPROVED BY CITY COUNCIL:  
RESOLUTION: 2025-094

*Rob Marler*

ROB MARLER, P.E. - CITY ENGINEER

## REQUIREMENTS ON PRE-FIRE PLANS

CITY OF OAKDALE  
DEPARTMENT OF PUBLIC SERVICES

DATE: 09-15-25

DRAWING NO.

**11-B-2**

# California Fire Code, Appendix D "Fire Apparatus Access Roads"

If "Private Access" roadways are not looped, then the provided dead-end private access roadways will meet the requirements as specified in the following table"

### Requirements For Private Dead-End Access-ways

<u>LENGTH</u>	<u>WIDTH</u>	<u>TURNAROUNDS REQUIRED</u>
*0 -150'	20'	Not Required
*151' - 500'	20'	120' Hammerhead, 60-Foot "Y", or 96' Diameter Cul-de-Sac
501' - 750'	26'	120' Hammerhead, 60-foot "Y", or 96' Diameter Cul-de-Sac

Over 750' - special approval required.

\* Curves and topographical conditions could alter the requirements for turnabouts and the width of access-ways.

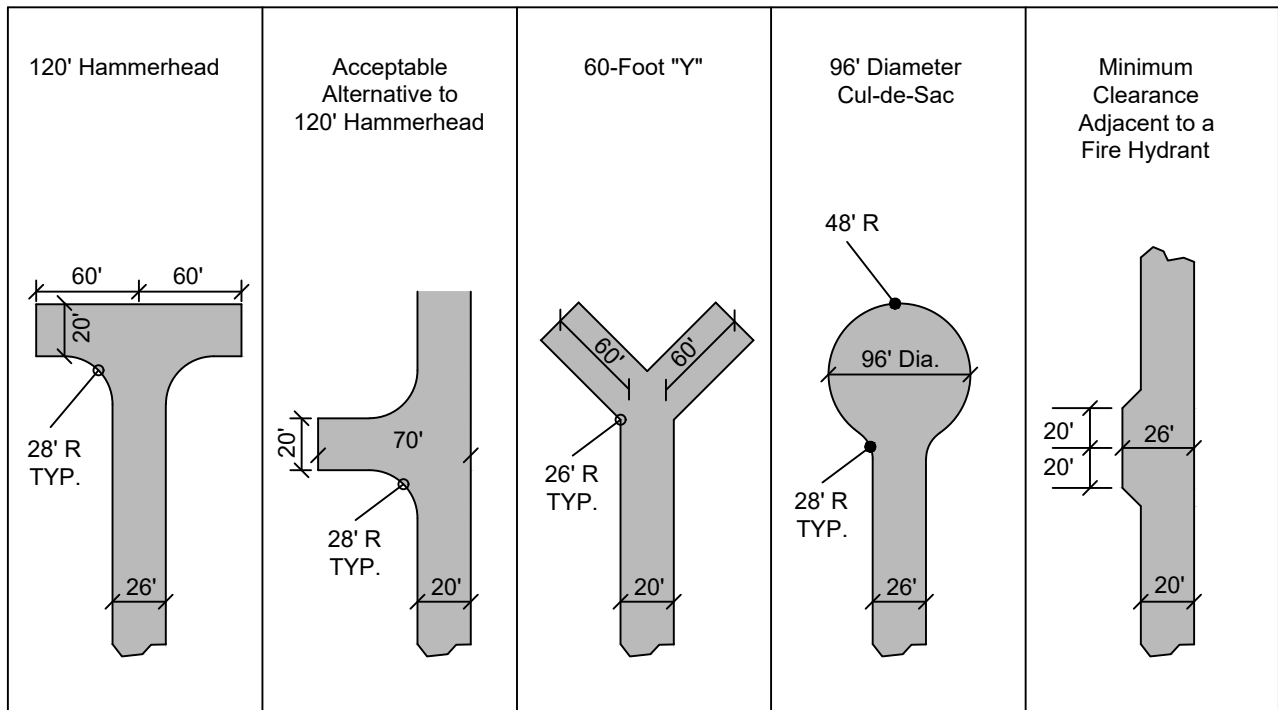

APPROVED BY CITY COUNCIL:  
RESOLUTION: 2025-094

*Rob Marler*

ROB MARLER, P.E. - CITY ENGINEER

## FIRE APPARATUS ACCESS ROADS

CITY OF OAKDALE  
DEPARTMENT OF PUBLIC SERVICES

DATE: 09-15-25

DRAWING NO.

# 11-C



Street Suffix Standards

Suffix	Abbreviated	Description	Direction
Ave	Avenue	A wide street or thoroughfare. A broad roadway with trees.	N/S
Blvd	Boulevard	A broad city street often tree-lined and landscaped.	N/S - E/W
Cir	Circle	Short roadways that are circular or semi-circular in and intersect the roadways from which they emanate at two different places.	
Ct	Court	A short street esp. a wide alley walled by buildings on three sides.	
Dr	Drive	A road for automobiles and other vehicles.	N/S
Lane	Lane	A narrow county road. A strip dedicated on a street or highway for a single line of vehicles.	N/S
Pky	Parkway	A broad landscaped highway often divided by a planted median strip.	N/S - E/W
Pl	Place	A public square or street with houses in a town.	E/W
Plz	Plaza	A public square or similar open area in town or city. A widened roadway forming the approach to tollbooths on a highway.	E/W
Rd	Road	An open public way for the passage of vehicles, people, and animals.	N/S
Row	Row	A continuous line of buildings along a street.	E/W
Sq	Square	An open, usu. Four sided area at the intersection of two or more streets, often planted with grass and trees for use as a park. A rectangular space enclosed by streets and occupied by buildings.	N/S - E/W
St	Street	A public way or thoroughfare in a city or town, usu. with a sidewalk or sidewalks.	E/W
Ter	Terrace	A residential street on top of or climbing a slope.	N/S - E/W
Way	Way	A road, path, or highway affording passage from one place to another.	E/W

**END OF SECTION**

APPROVED BY CITY COUNCIL:  
RESOLUTION: 2025-094



ROB MARLER, P.E. - CITY ENGINEER

## STREET NAMING STANDARD

CITY OF OAKDALE  
DEPARTMENT OF PUBLIC SERVICES

DATE: 09-15-25

DRAWING NO.

# 11-D-1

**FIGURE 1**

**3" SCHEDULE 40  
GALVANIZED STEEL PIPE  
OR 2"X2" SQUARE TUBING  
GALVANIZED STEEL TUBING  
1/4" WALL THICKNESS**

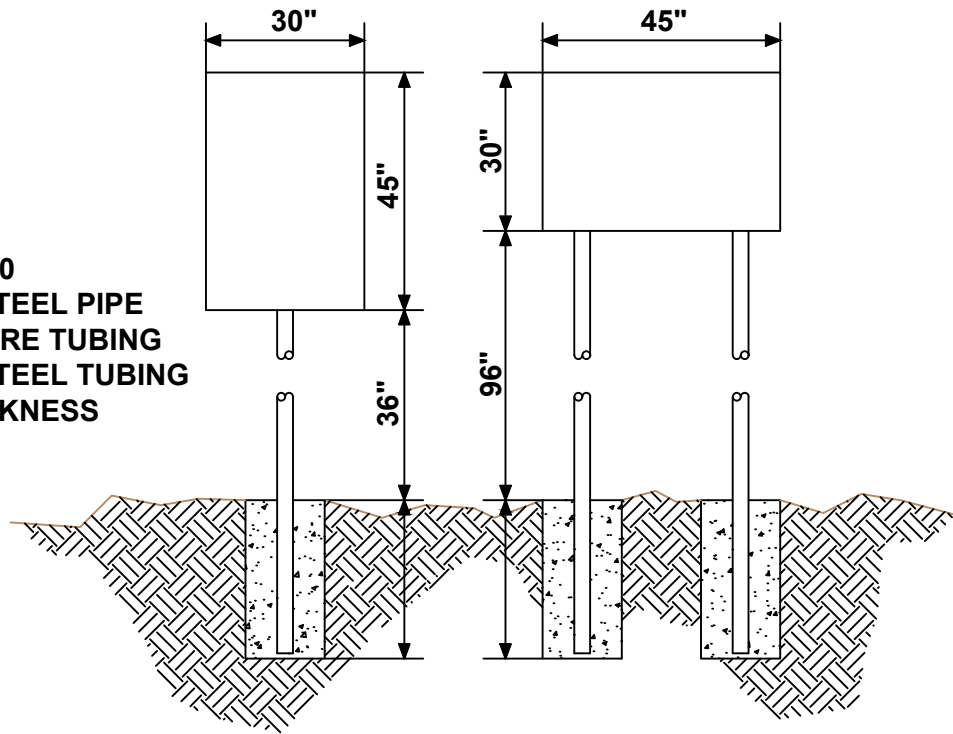

APPROVED BY CITY COUNCIL:  
RESOLUTION: 2025-094

*Rob Marler*

ROB MARLER, P.E. - CITY ENGINEER

**ILLUMINATED  
DIRECTORY**

CITY OF OAKDALE  
DEPARTMENT OF PUBLIC SERVICES

DATE: 09-15-25

DRAWING NO.

**11-E**

Figure I

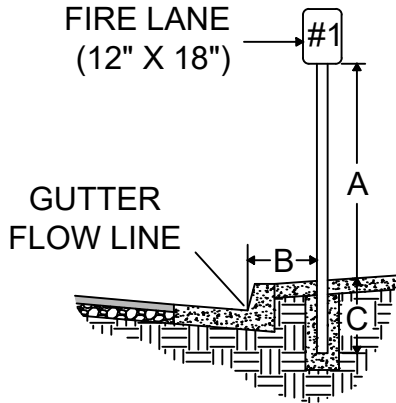

POST INSTALLATION

A = 7' height clearance in sidewalk or pedestrian areas.

B = 18" with Standard 24" Vertical Curb & Gutter.

C = 24" minimum embedment.

Note: Signs may be mounted on existing post or buildings, if post or building is no more than 24" from curb or edge of road surface. See Appendix D 103.6.1 & 2 for markings and posting of signs.

Figure II

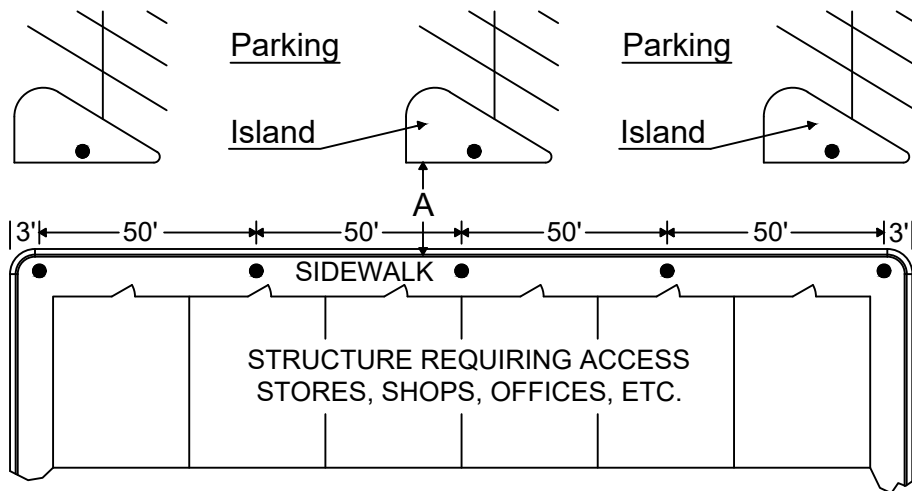

APPROVED BY CITY COUNCIL:  
RESOLUTION: 2025-094

*Rob Marler*

ROB MARLER, P.E. - CITY ENGINEER

**FIRE LANES**  
**OAKDALE FIRE DEPARTMENT**

CITY OF OAKDALE  
DEPARTMENT OF PUBLIC SERVICES

DATE: 09-15-25

DRAWING NO.

**11-F**

Figure III

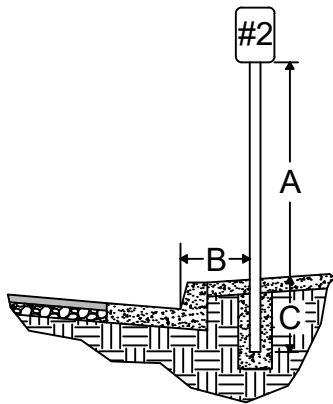

POST INSTALLATION

A = 7' height clearance in sidewalk or pedestrian areas.

B = 18" with Standard 24" Vertical Curb & Gutter.

C = 24" minimum embedment.

Note: Signs may be mounted on existing post or buildings, if post or building is no more than 24" from curb or edge of road surface.

Figure IV

"FACE OF CURB LETTERING"

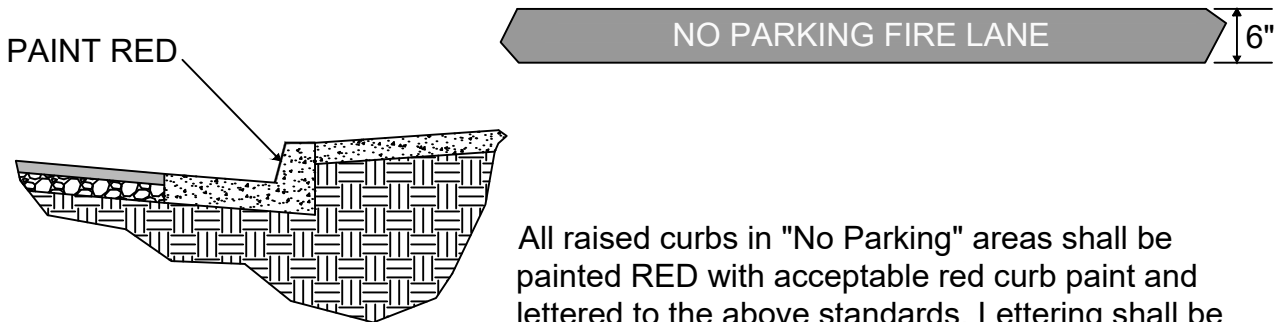

All raised curbs in "No Parking" areas shall be painted RED with acceptable red curb paint and lettered to the above standards. Lettering shall be 4" high, white and have a 3/4" stroke.

APPROVED BY CITY COUNCIL:  
RESOLUTION: 2025-094

ROB MARLER, P.E. - CITY ENGINEER

**FIRE LANES**  
**OAKDALE FIRE DEPARTMENT**

CITY OF OAKDALE  
DEPARTMENT OF PUBLIC SERVICES

DATE: 09-15-25

DRAWING NO.

**11-F-1**

Figure V

Any Street

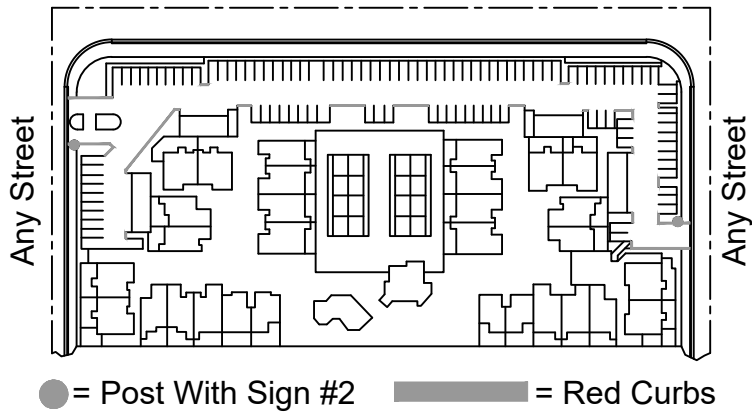
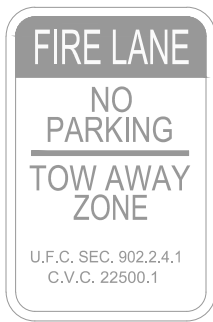

Figure VI



← Sign #1

**Fire Lane Sign**

12" X 18"  
Red on White  
ReflectORIZED  
.063 Gauge



→ Sign #2

**Entrance Sign**

18" X 24"  
Red on White  
ReflectORIZED  
.080 Gauge

Note: All information on signs must appear as shown.

APPROVED BY CITY COUNCIL:  
RESOLUTION: 2025-094

*Rob Marler*

ROB MARLER, P.E. - CITY ENGINEER

**FIRE LANES  
OAKDALE FIRE DEPARTMENT**

CITY OF OAKDALE  
DEPARTMENT OF PUBLIC SERVICES

DATE: 09-15-25

DRAWING NO.

**11-F-2**

1. Additional information should be included in the white diamond of the placard, when necessary to indicate special information about the hazards. See special abbreviation section in Figure 3, "DRAWING NO. 11-G-4".
2. The color of diamonds on the placard shall be as indicated in Figure 1, "DRAWING NO. 11-G-2".

**FIGURE 1**

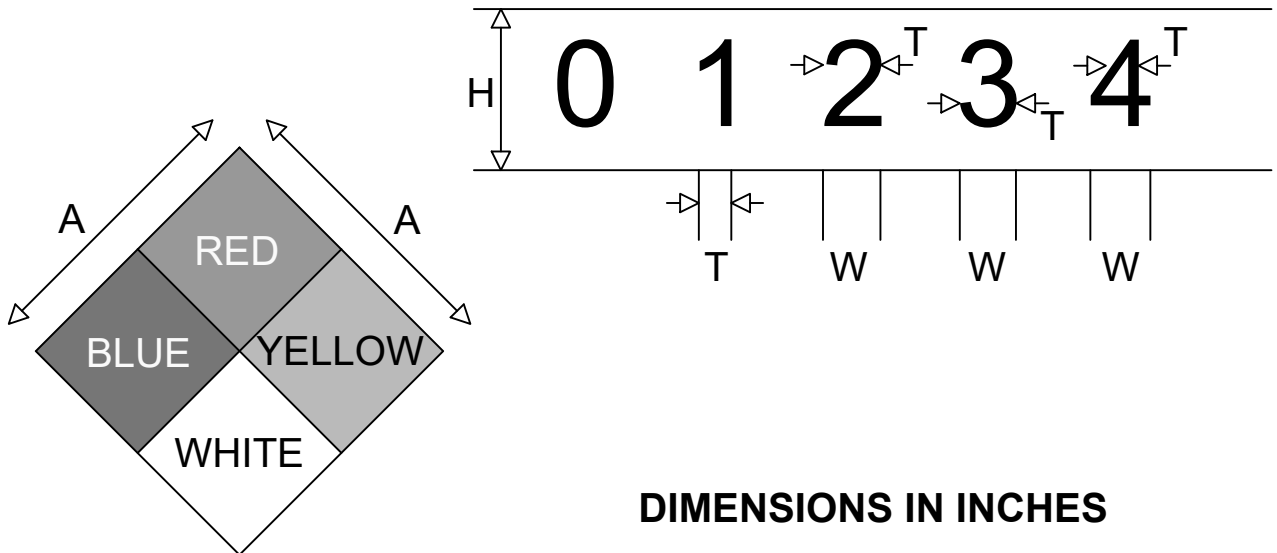

**DIMENSIONS IN INCHES**

	A	H	W	T
PLACARDS	12	5	3	3/4
LABELS	6	2	1	3/8

APPROVED BY CITY COUNCIL:  
RESOLUTION: 2025-094

*Rob Marler*

ROB MARLER, P.E. - CITY ENGINEER

**PLACARD AND LABELING  
REQUIREMENTS**

CITY OF OAKDALE  
DEPARTMENT OF PUBLIC SERVICES

DATE: 09-15-25

DRAWING NO.

**11-G**

**FIGURE 2**

Identification of Health Hazard Color Code: Blue		Identification of Flammability Color Code: Red		Identification of Reactivity (Stability) Color Code: Yellow	
Signal	Type of Possible Injury	Signal	Susceptibility of Materials to Burning	Signal	Susceptibility to Release of Energy
<b>4</b>	Materials that on very short exposure could cause death or major residual injury.	<b>4</b>	Materials that will rapidly or completely vaporize at atmospheric pressure and normal ambient temperature, or that are readily dispersed in air and that will burn readily.	<b>4</b>	Materials that in themselves are readily capable of detonation or of explosive decomposition or reaction at normal temperatures and pressures.
<b>3</b>	Materials that on short exposure could cause serious temporary or residual injury.	<b>3</b>	Liquids and solids that can be ignited under almost all ambient temperature conditions.	<b>3</b>	Materials that in themselves are capable of detonation or explosive decomposition or reaction but require a strong initiating source or which must be heated under confinement before initiation or which react explosively with water.
<b>2</b>	Materials that on exposure would cause irritation but only minor residual injury.	<b>2</b>	Materials that must be moderately heated or exposed to relatively heated or exposed to relatively high ambient temperatures before ignition can occur.	<b>2</b>	Materials that readily undergo violent chemical change at elevated temperatures and pressures or which react violently with water or which may form explosive mixtures with water.
<b>1</b>	Materials that on exposure would cause irritation but only minor residual injury.	<b>1</b>	Materials that must be preheated before ignition can occur.	<b>1</b>	Materials that in themselves are normally stable, but which can become unstable at elevated temperatures and pressures.
<b>0</b>	Materials that on exposure under fire conditions would offer no hazard beyond offer no hazard beyond that of ordinary combustible material.	<b>0</b>	Materials that will not burn.	<b>0</b>	Materials that in themselves are normally stable, even under fire exposure conditions, and which are not reactive with water.

APPROVED BY CITY COUNCIL:  
RESOLUTION: 2025-094



ROB MARLER, P.E. - CITY ENGINEER

## PLACARD AND LABELING REQUIREMENTS

CITY OF OAKDALE  
DEPARTMENT OF PUBLIC SERVICES

DATE: 09-15-25

DRAWING NO.

# 11-G-1

**FIGURE 3**

**OXIDIZERS = OXY**  
**CORROSIVES = COR**  
**ACIDS = ACID**  
**RADIOACTIVE = RAD**  
**WATER REACTIVE = W**  
**EXPLOSIVE = EXP**  
**PYROPHORIC = PYR**  
**POISON = TOX**

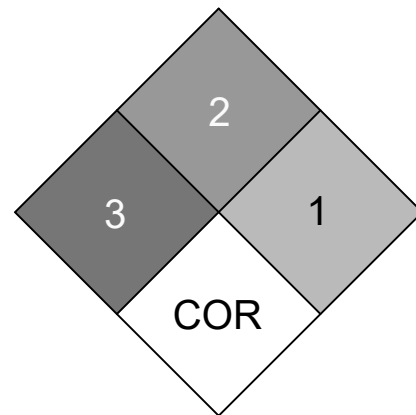

3. Placard and Label Manufacturers/Distributors

To assist businesses/facilities in obtaining manufactured placards and labels, the following companies have indicated that they carry and distribute these products. The Oakdale Fire Department and its employees do not endorse nor nor recommend any particular distributor or company. Any person or firm not on the list may be added by contacting the Oakdale Fire Department.

Lab Safety Supply  
P.O. Box 1368  
Janesville, WI 53547-1368  
(800) 356-0783

Granger  
Specialty Products Division  
1250 Busch Parkway  
Buffalo Grove, IL 60089  
(800) 521-5585

BWS Distributors, Inc.  
1849 Piner Road  
Santa Rosa, CA 95401  
(800) 862-4685

APPROVED BY CITY COUNCIL:  
RESOLUTION: 2025-094

*Rob Marler*

ROB MARLER, P.E. - CITY ENGINEER

**PLACARD AND LABELING  
REQUIREMENTS**

CITY OF OAKDALE  
DEPARTMENT OF PUBLIC SERVICES

DATE: 09-15-25

DRAWING NO.

**11-G-2**

MAXIMUM OCCUPANT  
CAPACITY

xxxx PERSONS  
SEATED - DINING

MAXIMUM OCCUPANT  
CAPACITY

xxxx PERSONS  
STANDING

APPROVED BY CITY COUNCIL:  
RESOLUTION: 2025-094



ROB MARLER, P.E. - CITY ENGINEER

# MAXIMUM OCCUPANT LOAD SIGNS

CITY OF OAKDALE  
DEPARTMENT OF PUBLIC SERVICES

DATE: 09-15-25

DRAWING NO.

# 11-H

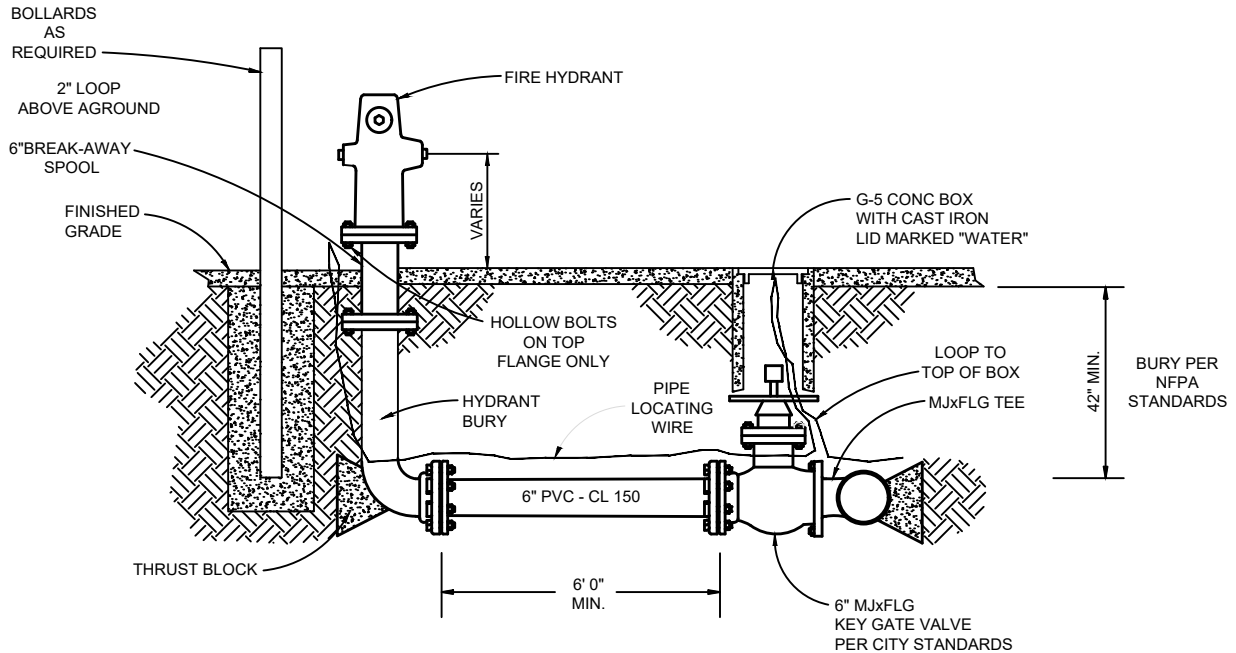

FIRE HYDRANT MANUFACTURER AND OUTLET QUANTITY - PER CITY OF OAKDALE STANDARD SPECIFICATIONS  
 CONTACT WATER SUPERVISOR FOR SPECIFICATIONS OF PIPE LOCATING WIRE

2001 CALIFORNIA FIRE CODE:  
 8001.11.3 PROTECTION FROM VEHICLES.

Guard posts (Bollards) or other approved means shall be provided to protect storage tanks and connected piping, valves and fittings; dispensing areas; and use areas subject to vehicular damage. When guard posts are installed, the posts (Bollards) shall be:

1. Constructed of steel not less than 4 inches in diameter and concrete filled.
2. Spaced not more than 4 feet between posts on center.
3. Set not less than 3 feet deep in a concrete footing of not less than a 15 inch diameter.
4. Set with the top of the posts not less than 3 feet above ground.
5. And located not less than 5 feet from the tank.

APPROVED BY CITY COUNCIL:  
 RESOLUTION: 2025-094

*Rob Marler*

ROB MARLER, P.E. - CITY ENGINEER

# FIRE HYDRANT - GATE VALVE INSTALLATION

CITY OF OAKDALE  
 DEPARTMENT OF PUBLIC SERVICES

DATE: 09-15-25

DRAWING NO.

**11-1**

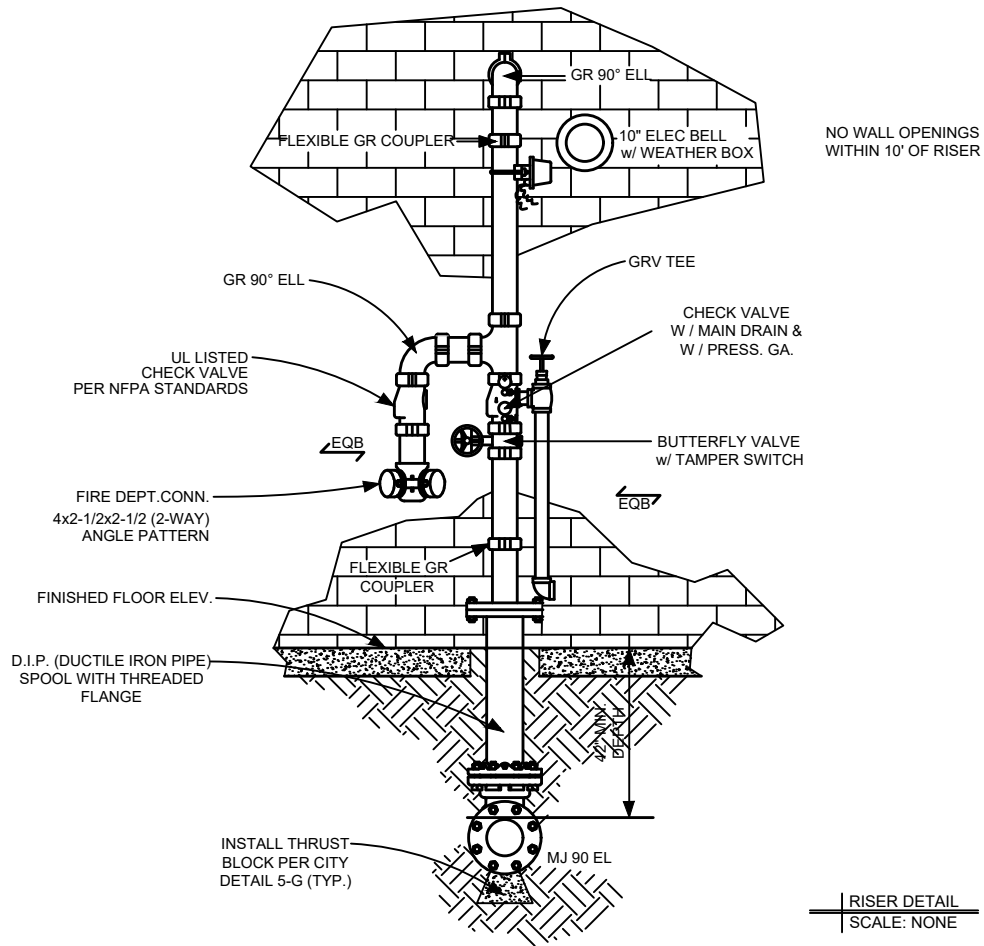

NOTES:

1. WHERE PIPE PASSES THROUGH HOLES IN THE PLATFORMS, FOUNDATIONS, WALLS OR FLOORS. THE HOLES SHALL BE SIZED SUCH THAT THE DIAMETER OF THE HOLES IS NOMINALLY 2 IN. LARGER THAN THE PIPE FOR PIPE 1 IN. NOMINAL TO 3 1/2" NOMINAL AND 4 IN. LARGER THAN THE PIPE FOR 4 IN. NOMINAL AND LARGER.
2. CONTRACTORS OR DEVELOPER SHALL SUBMIT FORM NFPA 24, "CONTRACTORS MATERIAL AND TEST CERTIFICATE FOR UNDERGROUND AND ABOVE GROUND PIPING", TO THE CITY OF OAKDALE FIRE DEPARTMENT FOR APPROVAL AND THEIR RECORDS.
3. THE FDC & MAIN VALVE WILL BE ALLOWED ON THE RISER IF THE FOLLOWING CONDITIONS EXIST:
  - A) RISER IS ACCESSIBLE FROM A PUBLIC STREET WITHOUT CROSSING ANY BARRIERS (GATES / FENCES ETC.)
  - B) THE RISER IS LOCATED WITHIN SEVENTY (70') FEET OF THE PUBLIC ROAD CURB FACE.
  - C) A PRESSURE RELIEF VALVE WILL BE REQUIRED ON THE SYSTEM SIDE OF THE CHECK VALVE.
  - D) THE VALVE MAY BE LOCATED AT THE GAGE ON THE RISER OR AS PART OF THE INSPECTORS TEST VALVE ASSEMBLY.

APPROVED BY CITY COUNCIL:  
RESOLUTION: 2025-094

*Rob Marler*

ROB MARLER, P.E. - CITY ENGINEER

# RISER DETAIL

CITY OF OAKDALE  
DEPARTMENT OF PUBLIC SERVICES

DATE: 09-15-25

DRAWING NO.

**11-J**



# Knox® Key Switch 3500 Series

For Emergency Override



Gated communities, apartment complexes, parking garages, pedestrian gates and industrial receiving areas are just a few applications of the Knox® electric override key switch. It can be ordered with single or dual key options for fire, EMS and law enforcement access.

### Features and Benefits

- Single or dual key switch
- Fire, EMS or law enforcement identification labels
- One position, two position or momentary switch
- Face plate and lock cover ensure weather resistant operation.

### Electrical Data

- SWITCH: SPDT or DPDT
- 7 A resistive, 4 A inductive, (sea level), 28 VDC.
- 7 A resistive, 2.5 A inductive, (50,000 ft.), 28 VDC.
- 7 A resistive or inductive, 115 VAC., 60 Hz.
- UL® and CSA listed: 7 A, 250 VAC.
- Temperature tolerance up to +180° F.

#### Knox® Rapid Entry System

The Knox Company manufactures a complete line of high security products including Knox-Box key boxes, key vaults, cabinets, key switches, padlocks, locking FDC caps, plugs and electronic master key security systems. For more information or technical assistance, please call Customer Service at 1-800-552-5669.



### Single Switch Model 3502

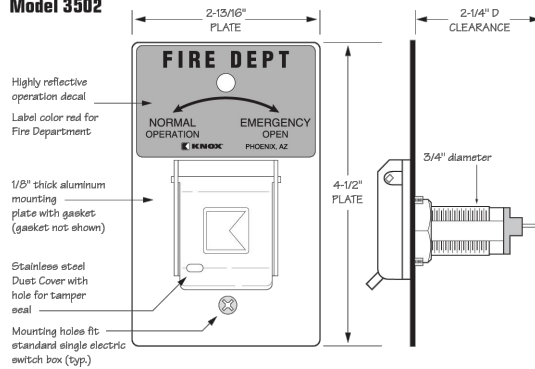

### Dual Switch Model 3503

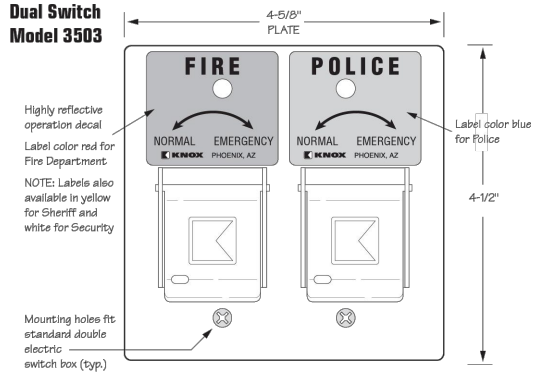

### Ordering Specifications

Dimensions: Requires 2 1/4" recessed depth x 3/4" diameter  
 Switch: SPDT or DPDT; 7A resistive, 4A inductive., key removable two position.  
 Mounting: Key switch is designed to be recess mounted.  
 P/N: 3500 Series Knox Key Switch (mfr's cat. ID)  
 Mfr's Name: KNOX COMPANY



KNOX COMPANY • 1601 W. Deer Valley Road, Phoenix, AZ 85027 • (800) 552-5669 • (623) 687-2300 • Fax (623) 687-2299 • Web: www.knoxbox.com • E-mail: info@knoxbox.com

© Copyright 2012. Knox Company

MKT-KBSPC-0028-D

APPROVED BY CITY COUNCIL:  
RESOLUTION: 2025-094

ROB MARLER, P.E. - CITY ENGINEER

# MAIN ELECTRICAL SERVICE DISCONNECT

CITY OF OAKDALE  
DEPARTMENT OF PUBLIC SERVICES

DATE: 09-15-25

DRAWING NO.

# 11-K